

Parts List

Description	Qty.	Part No.
A toggler (ACC 215 only)	2	560-9708
toggler (ACC 415 only)	4	560-9708
toggler (ACC 615 only)	6	560-9708
B 1/4-20 x 2.5" phillips (ACC 215 only)	2	520-9521
1/4-20 x 2.5" phillips (ACC 415 only)	4	520-9521
1/4-20 x 2.5" phillips (ACC 615 only)	6	520-9521
C 1/4" SAE washer (ACC 615 only)	6	540-9440

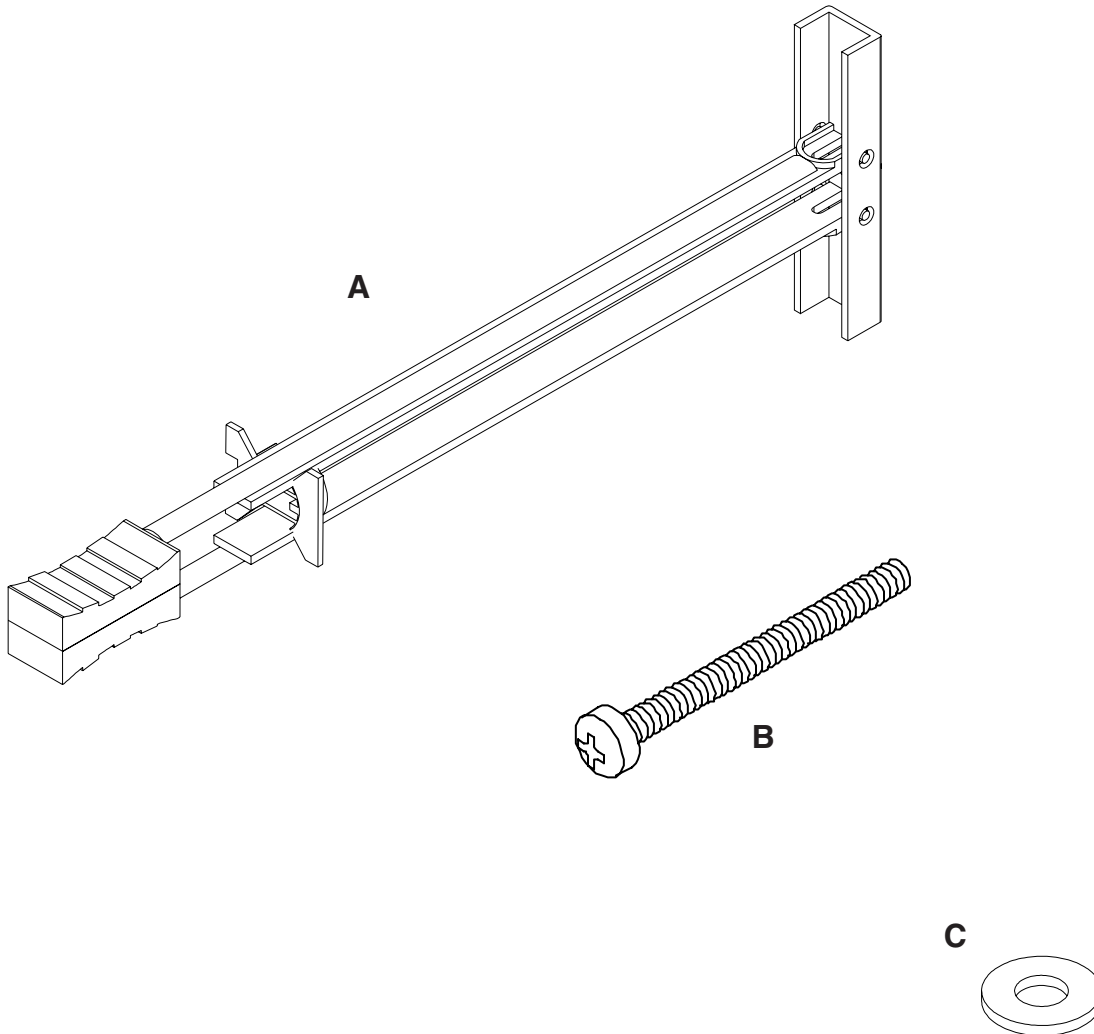

- 1** **FOR METAL STUD WALLS ONLY:** Drill four 1/2" (13mm) dia. holes through drywall and studs at locations corresponding to wall plate. Insert togglers (A) as shown below...

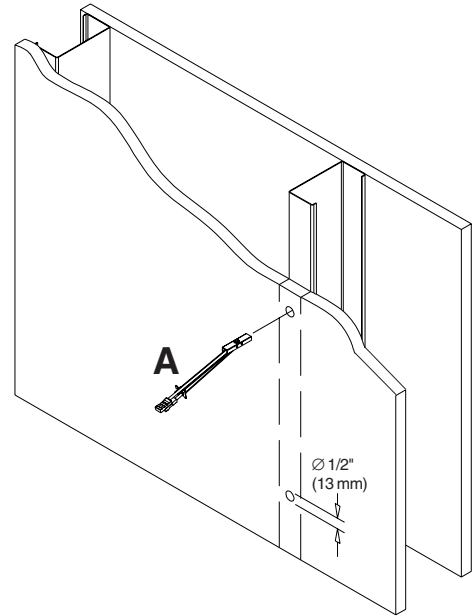

⚠ WARNING

- Product must be mounted through drywall that has a minimum thickness of 1/2" and into metal studs, 26 gauge or heavier.
- Make sure that togglers are anchored into the center of the studs as shown in figure 1. The use of an "edge to edge" stud finder is highly recommended.

- 1-1** Pivot end of toggler (A).

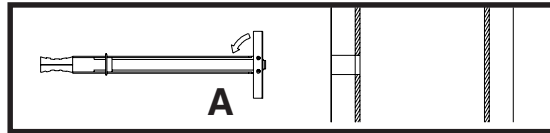

- 1-2** Push into hole.

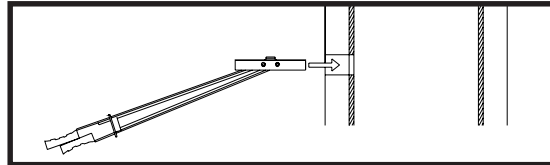

- 1-3** Rotate toggler (A) clockwise to wedge it against inside walls of metal stud.

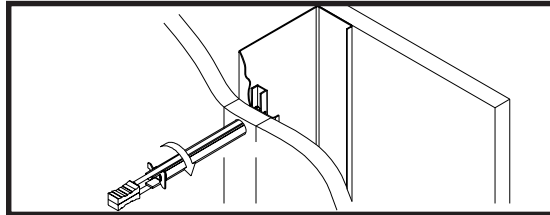

- 1-4** Slide plastic cap forward while pulling back firmly on ring.

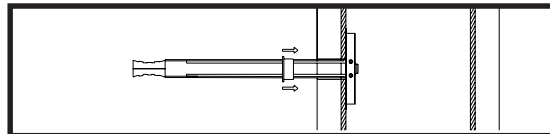

- 1-5** Break off excess.

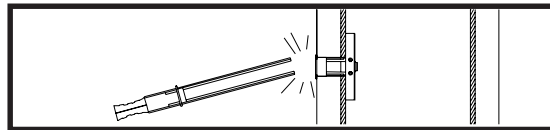

- 1-6** Align wall plate with hole in wall and fasten using 1/4-20 x 2.5" screw (B) and 1/4" washer (C).

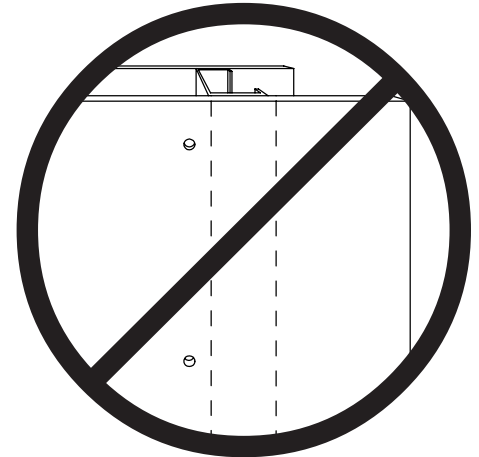
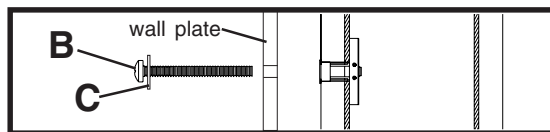

fig. 1