

# EasyStand<sup>ii</sup> Bantam

Extra Small & Small

Please ensure the Owner's Manual stays with the unit at all times.



Owner's Manual

## SYMBOL LEGEND



**CAUTION/ATTENTION**



**ENVIRONMENTAL  
CONDITIONS**



**TYPE BF APPLIED PART**



**DATE OF MANUFACTURE**



**PINCHPOINT**



**SEE INSTRUCTIONS FOR USE**

**SN**

**SERIAL NUMBER**



**MANUFACTURE**



Please be environmentally responsible and recycle this product through your recycling facility at its end of life.

**R<sub>x</sub>only**

Afin de préserver l'environnement, veuillez confier ce produit à votre centre de recyclage à la fin de sa durée de vie.

Nachdem dieses Produkt ausgedient hat, entsorgen Sie es bitte auf umweltfreundliche Weise, indem Sie es zu der entsprechenden Recyclingstelle bringen.

Wees a.u.b. milieubewust en recycleer dit product via uw recycleerder na het verstrijken van de levensduur.

Sea responsable con respecto al medio ambiente y recicle este producto al finalizar su vida útil en el lugar de reciclaje correspondiente.

Siate responsabili verso l'ambiente e riciclate questo prodotto, al termine della sua vita d'uso, presso la vostra sede di riciclaggio.

Kierrätä tämä tuote sen käyttöiän lopussa ympäristövastuullisella tavalla paikallisella kierrätyslaitoksella.

Var miljömedveten och återvinn denna produkt efter dess användning.

Vi ber deg ta hensyn til miljøet og resyklere dette produktet ved hjelp av de rette resyklingsfasilitetene når produktet ikke lenger kan brukes.

Vis venligst hensyn til miljøet ved at levere produktet til det nærmeste genbrugsanlæg, når det ikke længere fungerer.

Por favor, assumo responsabilidade ambiental, reciclando este produto em suas instalações de reciclagem no final de sua vida útil.

# Table of Contents

<b>Introduction</b> . . . . .	<b>1</b>
<b>Safety Precautions</b> . . . . .	<b>2</b>
<b>Assembly</b> . . . . .	<b>3</b>
<b>Mobile Assembly</b> . . . . .	<b>12</b>
<b>Adjustments &amp; Usage</b> . . . . .	<b>14</b>
<b>Pow'r Up Lift Option Usage</b> . . . . .	<b>23</b>
<b>Parts Detail</b> . . . . .	<b>28</b>
<b>Standing</b> . . . . .	<b>29</b>
<b>Maintenance</b> . . . . .	<b>30</b>
<b>TroubleShooting</b> . . . . .	<b>31</b>
<b>Limited Warranty</b> . . . . .	<b>32</b>

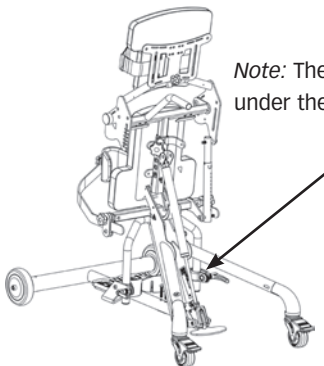

*Note:* The serial number is located under the seat in the seat column.

Date Purchased \_\_\_\_\_ Serial # \_\_\_\_\_

# Introduction

Congratulations on your purchase of an EasyStand standing frame! We at Altimate Medical have designed the EasyStand with your comfort and happiness in mind.

## EasyStand Description

The EasyStand line of products is intended for individuals who are able to transfer independently or with assistance from a caregiver and/or lifting device. It is a useful tool for rehabilitation, home, school, and work use. EasyStand standing frames support the user from sitting to the standing position. Various options such as support, choice of manual or Pow'r Up Lift may be added to facilitate individual needs.

## Indications for Use

The EasyStand Bantam line of products is intended to assist individuals who have difficulty rising from a seated position to a standing position and is indicated for individuals weighing up to 50 lbs. (Extra Small), 100 lbs. (Small).

**This manual is an integral part of your standing system and should be read completely and thoroughly by anyone that will be operating the unit.** This will ensure the EasyStand is assembled properly and used in the most beneficial manner.

**Altimate Medical recommends that an attendant be present when the EasyStand is being used.** Should any problem arise that you cannot solve by reading this manual, please contact your local supplier or call Altimate Medical, Inc., at 800-342-8968 or 507-697-6393.

It is necessary to inspect your EasyStand Bantam at least weekly to ensure it is in safe operating condition. EasyStand adjustments that are listed in the product owner's manual can be made by the operator by following the instructions for use. After an adjustment is made, inspect the EasyStand to ensure all hardware and adjustable components are properly secured per the instructions for use. Replacement of worn parts, major adjustments, or any other important corrections should be handled by an authorized supplier or service center. Only Altimate Medical, Inc., approved replacement parts should be used to ensure safety and performance.

**Do not use the EasyStand Bantam without consulting your physician. Failure to consult a qualified physician prior to using the EasyStand Bantam could lead to severe medical problems. We recommend a good standing program be established and supervised by a qualified physician or physical therapist.** **R<sub>x</sub>only**

## Join the Standing Community!

Our goal is simple - to empower people with disabilities to stand up for their health. Connect, share, and learn from other people with disabilities, special needs parents, clinical professionals, and the experts in standing on our social networking communities. By keeping your standing program "top of mind" you will have the greatest chance of maintaining a standing routine that maximizes all the benefits of standing!

# Safety Precautions

- Please read and understand all safety precautions and user instructions prior to use. Call Altimate Medical at 800-342-8968 or 507-697-6393 with any questions or for additional information.
- If a user does not meet the specifications below and has not been properly fitted by a qualified therapist or physician, Altimate Medical, Inc., does not recommend using the EasyStand Bantam.

**Bantam (Extra Small)** - is designed to accommodate most individuals from 28"-40" (71-102cm) and up to 50 lbs. (23kg)

**Bantam (Small)** - is designed to accommodate most individuals from 36"-54" (91-137cm) and up to 100 lbs. (45kg)

*For more detailed specifications visit our website [www.easystand.com](http://www.easystand.com)*

- The EasyStand Bantam should not be used without first consulting a qualified physician. Failure to consult a qualified physician prior to using the EasyStand Bantam could lead to severe medical problems. We recommend a good standing program be established and supervised by a qualified, registered physical therapist.
- The EasyStand Bantam should always be used with a qualified adult attendant present. Never leave a child unattended in the Bantam.
- Do not make adjustments to the Bantam while in the standing position. **Exception: If the supine option was ordered, refer to pages 17-19. Changes in position must be performed or supervised by a qualified caregiver or medical professional.**
- It is necessary to inspect the EasyStand Bantam at least weekly to ensure it is in safe operating condition. Pay particular attention for loose hardware. If the EasyStand is equipped with the optional Pow'r up lift, please inspect the electrical cables for any wear and ensure they are attached properly. Replacement of worn parts, major adjustments, or other important corrections should be handled by an authorized dealer or service center. Only Altimate Medical, Inc., approved replacement parts should be used to ensure safety and performance.
- If the EasyStand is being used in the home environment, please inspect the unit prior to each use to ensure there is no damage or unexpected wear to the EasyStand that may have been caused unintentionally by pets, pests or children.
- Never reposition the foot plates while the user is in the standing position. Consult with a therapist or physician for proper foot placement and angle.
- Never elevate the legs or adjust the backrest to anterior tilt using the following arm adjustment. Only the supine option may be used to elevate the legrest with simultaneous recline of the backrest.
- Ensure the necessary support and alignment options are in position prior to bringing the child into the standing position.
- If the unit was exposed to temperatures of less than 50°F (23.5°C), the unit must warm to room temperature before use.
- **Operating Conditions:** Temperature: 41°F (5°C) -104°F (40°C), Relative humidity: 20% - 90% at 86°F (30°C), Atmospheric Pressure: 700 to 1060hPa.
- **Storage/Transport Conditions:** Temperature: 14°F (-10°C) -122°F (50°C), Relative humidity: 20% - 90% at 86°F (30°C), Atmospheric Pressure: 700 to 1060hPa.
- The EasyStand can be used at a maximum altitude of 10,000 feet (3,050 meters).
- The expected service life of an EasyStand is considered 5 years under normal use conditions. Note: This may vary based on frequency of use.
- Standing equipment is designed for indoor use on level surfaces only. Keep casters locked while in use.
- Transporting the unit with a user in the standing position is not recommended.
- Extreme movements laterally or front to back may cause the unit to tip.
- It is recommended the equipment be stored at normal room temperature and humidity levels.
- Altimate Medical products are specifically designed to be used with Altimate Medical accessories and options. Unless otherwise noted, accessories and options from other manufacturers have not been tested by Altimate Medical and are not recommended for use with Altimate Medical products.
- Product Modifications made without express written consent (including, but not limited to, modification through the use of unauthorized parts or attachments) are not recommended and will void the product warranty.
- The EasyStand Bantam Electric Lift meets the requirements of IEC 60601-1 and 60601-2.\*
- The wheel lock on the mobile option is to keep the unit in place while transferring or standing stationary and it is **not** intended to be used as a dynamic brake to stop a rolling mobile unit.

 **Caution:** This equipment is designed to accommodate a range of users; therefore the unit has various adjustment slots and holes. Avoid placing fingers or other body parts in any of these areas.

 **Caution:** While in use this equipment has various moving parts, familiarize yourself with the unit and avoid placing hands or fingers near any of these areas.

 **Caution:** Advise bystanders to keep clear of the unit while in use.

 **Caution:** Do not use the EasyStand Bantam Mobile option on an incline, it is intended for level surfaces only. Doing so may cause the unit to tip.

\* Bantam Pow'r Up Lift Option Only

# Assembly

1. Remove all parts from the box. If you ordered the Swing-Away Front option with Front Swivel casters, attach the casters to the axel as shown. Line up the bolt and nut, using a 17mm wrench and hex wrench, tighten the nut securely.

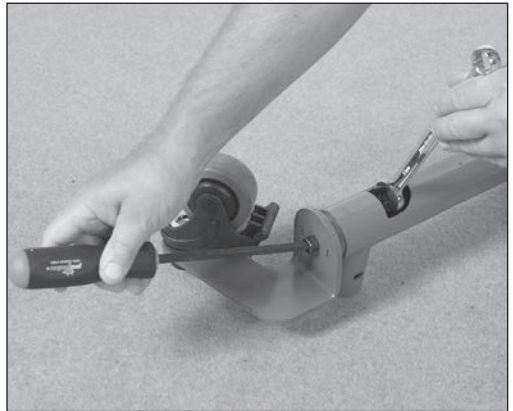

2. Remove the two bolts and two covered nuts from front frame.



3. Flip up the rear frame to allow easier access to the post. Attach the front and rear frames to one another.



4. Place the two covered nuts into the bottom of the frame and flush with the tube. You may have to tap them in with a rubber hammer to make them flush.

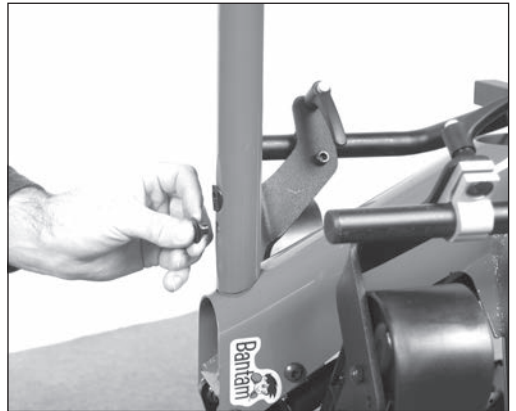

5. Place the two bolts into the top of the frame and screw into the covered nut, making sure they are flush. Tighten securely.



6. Place the unit back in the normal position. If you ordered the optional adjustable removable pump handle, remove knob, bolt and spacer from center of handle. Insert spacer as shown.



7. Place bolt into the spacer as shown. Place knob onto bolt and tighten securely.



8. Remove pin from the pump, place pump handle onto pump shaft as shown and place pin through holes. Place top of handle on to the handle, insert 2 bolts and tighten securely.



9. Use the optional pump handle or step on the gas spring assist pedal to raise the seat about 3/4 the way up as shown. Line up the following arm with the back angle tube.





**10.** Depress the spring button to allow the following arm to slide into place. Match the following arm position color with the corresponding seat depth color. (for information on seat adjustments see pg. 15)



**11.** Loosen the ratchet handles on the foot plates and swivel into place (for information on foot plate adjustments see pg. 14).



**12A.** Insert each knee bracket into the tubes onto the unit, with the clamp down.

**12B.** Depress the spring button to allow the bracket to slide into place, advance until the spring button locks into place.

For the Swing-Away Knee Pads, insert bracket into place and tighten knobs securely.

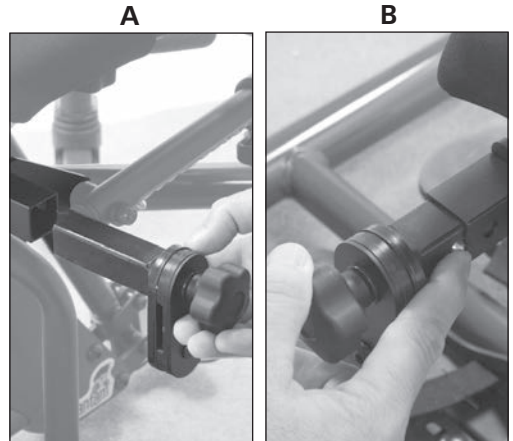

**13.** Insert each knee pad bracket into the slots on the knee bracket. Tighten knobs securely.



**14.** Remove knob and metal washer from the knee pad, leaving the rubber washer in place on the knee pad, place the knee pad and rubber washer onto the knee pad bracket. Place metal washer and knob onto bolt as shown. Repeat steps for the opposite side (for information on knee pad adjustments see pg. 14).



**15.** If you ordered the Supine option, remove the controller from the packaging. Remove the two bolts on the bottom of the controller, leaving nuts in place.



**16.** Place controller onto the bracket on the side of the unit. The bracket will slide into the slot on the bottom of the controller.



**17.** Making sure the nuts are in the back on the controller, line up holes and insert both bolts. Tighten securely.



**18.** If you ordered the Swing-Away Front, remove the tray bracket from the H-frame and set the bracket aside for step 19. Place the H-frame onto the the base of the unit, making sure the swivel collar is placed onto the tube insert.

*If you ordered a Shadow Tray, please skip to step 24.*

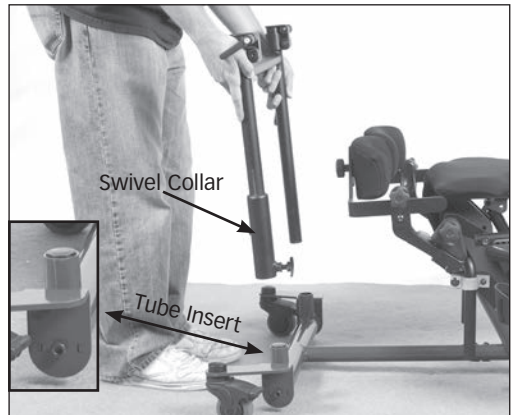

**19.** Place the collar onto the frame until the plunger locks into place. The plunger handle needs to be pulled out to lock into place.



**20.** Place the tray upside down, remove the knob, nut, and washers from both tray slides and set aside. Place the tray bracket onto the bolts with the shorter ends of the bracket facing the chest pad.

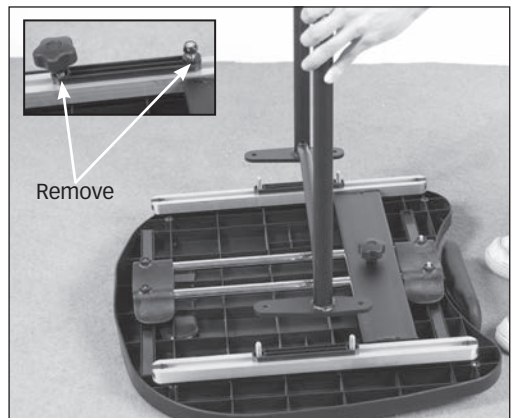

**21A.** Place the knobs onto each bolt and tighten snug.

**21B.** Place the two washers onto each bolt, then place the nut onto each bolt and tighten until you expose a thread, the washers should still be able to spin freely.

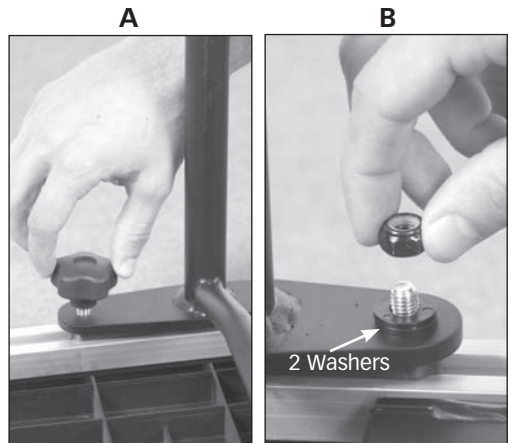

22. Place the table bracket into the H-frame.

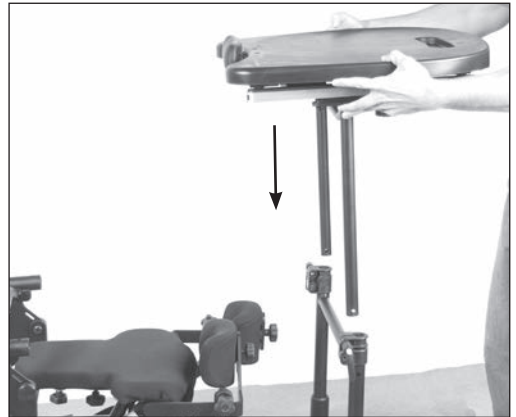

23. Depress the spring button to allow the bracket to slide into the H-frame (A). Once you clear the clamp the spring button needs to be depressed again and allow the tray to slide into position (B).

*Note: There is only one spring button. The spring button will stop in the maximum height position. Tighten knobs to secure the tray height.*



24. If you ordered the optional Shadow Tray, loosen the ratchet handles on the side of the tray, flip the arms up so they are lined up with the tray as shown and tighten the ratchet handles. Insert the two tray arms into the tray bracket on the bottom of the tray. One of the arms is longer than the other for easier installation (for information on Shadow Tray adjustments see pg. 20-21). The bolts on the arms are used as a stop for future reference. Place the quick release pins into the holes of the tray to secure into place.

**Caution:** After placing the tray into position, ensure the ratchet handles on the side of the tray are tightened securely.

For the Swing-Away Shadow Tray, remove plastic from knobs on unit, loosen knobs, insert tray and tighten securely.



Shadow Tray



Swing-Away  
Shadow Tray

**25.** If not already on the unit, remove the knob from the center post and place the back onto the unit as shown.



**26.** Place the back in the desired position. Insert knob and tighten securely.

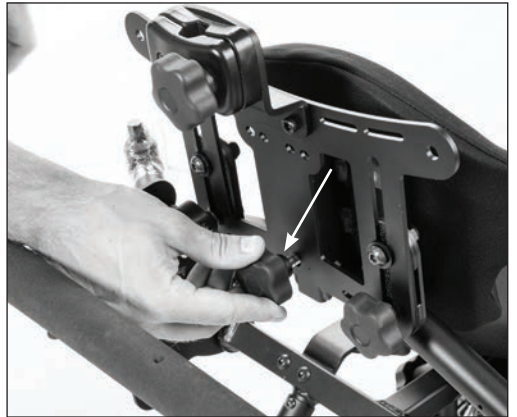

**27.** If you ordered only the optional headrest, insert the head support onto the unit and tighten securely.



# Mobile Option Assembly

*Note: If this is an option added after the initial purchase, you must remove the existing front assembly before proceeding.*

**28.** The Mobile option consists of two drive wheel assemblies, a "T" style front weldment, barrel nuts and bolts. You will need a 5mm allen wrench and a rubber hammer for assembly.



**29.** Set the Bantam on its back and attach the "T" weldment to the frame. Note that the front curves upward.



**30.** Line up holes and place the covered nuts on the bottom of the frame. You may have to tap them with a rubber hammer to make them flush. Tighten bolts securely.



**31.** Attach the interchangeable right and left drive wheel assemblies to the front frame.



**32.** Line up the holes and tap in the covered nuts and tighten bolts securely. Making sure the covered nuts are flush with the base. Position the Bantam upright and re-tighten the frame bolts.

Return to step 6.



### **Mobile Adjustment & Usage**

To lock or unlock the drive wheels, turn the drive wheel lock one quarter turn.

Use the push rim adjustment to position the push rims forward or aft, for transferring or self-propulsion. Tighten to lock in position.

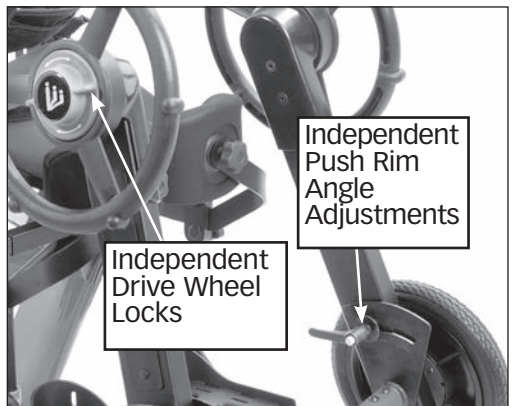



# Adjustments & Usage

## Gas Cylinder

Place foot on the pedal and lift using the assist handle behind the seat to help raise the unit to the standing position. This may also be necessary when lowering the user to the seated position.

## ⚠️ Foot plates

**Caution:** Never reposition the foot plates with the child in the standing position.

**Caution:** Avoid placing fingers in the adjustment slot.

**FIG. A-Height**-The standard foot plates have height adjustment only. Loosen the clamp connecting the foot bracket to the seat post to adjust foot plate height.

The Multi-Adjustable Foot plates have a wide variety of adjustments:

**FIG. B-Plantar/Dorsi**-Loosen clamps to tilt foot plates.

**FIG. C-Adduction**-Loosen clamps to slide foot plates together.

**FIG. D-Forward/Aft**-Loosen knobs underneath foot plates, slide foot plates into position.

**FIG. E-Toe-in/Toe-out**-Loosen knobs underneath foot plates, slide foot plates into position.

**FIG. F-Abduction**-Loosen clamps to spread apart foot plates, tighten clamps. Loosen knobs under foot plates and slide foot plates apart.

Always tighten knobs securely.

## Knee Pads

**FIG. G**-The standard knee pads have depth and pad rotation adjustments only. To adjust the knee pads, loosen the knobs and move into position. Tighten securely once desired position is reached.

**FIG. H**-The Swing-Away Knee pads swing out of the way by depressing the red button, they also have width and height adjustments.

**Caution:** Make knee pad adjustments while child is in the seated position only.

**FIG. A**  
Height

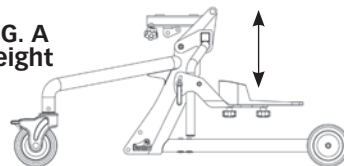

**FIG. B**  
Plantar/Dorsi

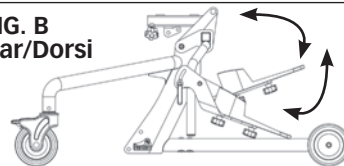

**FIG. C**  
Adduction

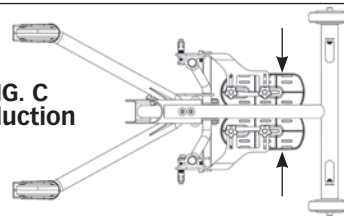

**FIG. D**  
Forward/Aft

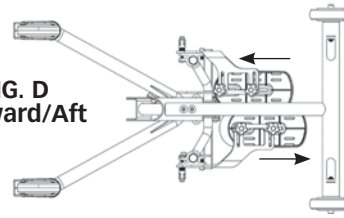

**FIG. E**  
Toe-in/Toe-out

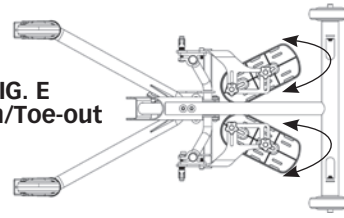

**FIG. F**  
Abduction

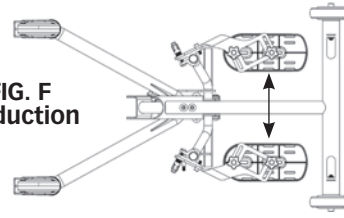

**FIG. G**  
Standard Knee pads

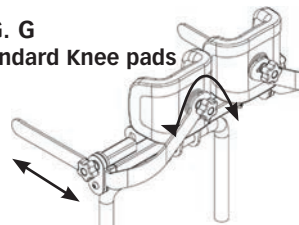

**FIG. H**  
Swing-Away Knee pads

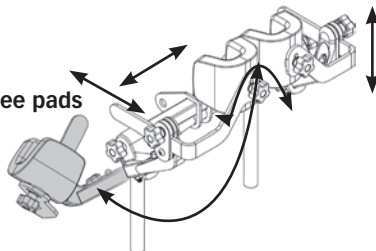

## Seat Depth/Back Angle/Back Height

⚠ **Caution:** Do not adjust the seat depth while the child is in the unit.

⚠ **Caution:** Ensure the colors on the seat tube and following arm match.

First remove the Shadow Tray and bring the seat up to a slight angle.

**33.** Loosen the knobs on the seat tube and the following arm. Do not unscrew knobs out all the way when adjusting the seat.

The Bantam **Extra Small** back angle adjustments are located above the locking knob. The back angle adjustments go from green (largest) to blue (smallest).

The Bantam **Small** back angle adjustments are located below the locking knob. The back angle adjustments go from blue (smallest) to green (largest).

**34. Adjusting to a shorter setting:** Adjust the following arm (back angle) first by depressing the spring button and moving no more than two holes at a time. Then adjust the seat tube (seat depth) one hole at a time. Continue this sequence until you achieve the desired setting and the colors on the seat tube and following arm match.

**Adjusting to a longer setting:** Adjust the seat tube (seat depth) first by depressing the spring button and moving only one hole at a time. Then adjust the following arm (back angle) no more than two holes at a time. Continue this sequence until you achieve the desired setting and the colors on the seat tube and following arm match.

**Note:** For easier adjustment you may need to lift slightly as the seat depth adjustment is made.

Tighten the seat depth and following arm knobs securely when you have achieved the desired position.



## Hip Supports/Lateral Supports Options

**36.** The optional hip supports can be removed for transferring. The hip support width can be adjusted by loosening the knobs underneath the seat. Loosen the knob on the side of the unit to adjust the hip support width. Always tighten securely.

The hip supports have a number of attachment holes on the back of the pad allowing for additional positions vertically and horizontally. The pads can also be bolted on at a straight, 90°, 180°, or 270° position.

**37.** The optional lateral supports can be removed for transferring. The lateral support width can be adjusted by loosening the knobs on the back of the unit. Always tighten securely.

The lateral supports have a number of attachment holes on the back of the pad allowing for additional positions vertically and horizontally. The pads can also be bolted on at a straight, 90°, 180°, or 270° position.

Please check for fit and interference by bringing the unit to the maximum standing position and back to sitting again (without a user seated in the unit) as the pads may not work perfectly in all positions.

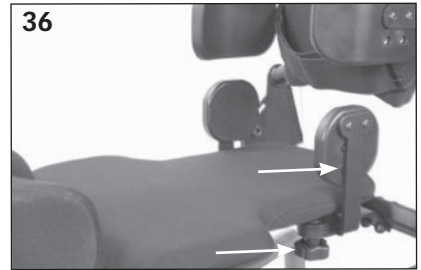

Hip Supports



Lateral Supports

## Accessories Mounting Bracket

**38.** The accessories mounting bracket is attached to the back of the unit and is used for a wide range of options. The holes in the middle can be used for many styles of aftermarket head supports. There are holes for the chest vests, chest straps, and lateral supports. This bracket is standard on all units.

### Attaching the Chest Vest

**39.** Insert chest vest clips into slots as shown with tab facing up.

**40.** Once the tab is past the bracket, pull back until snug.

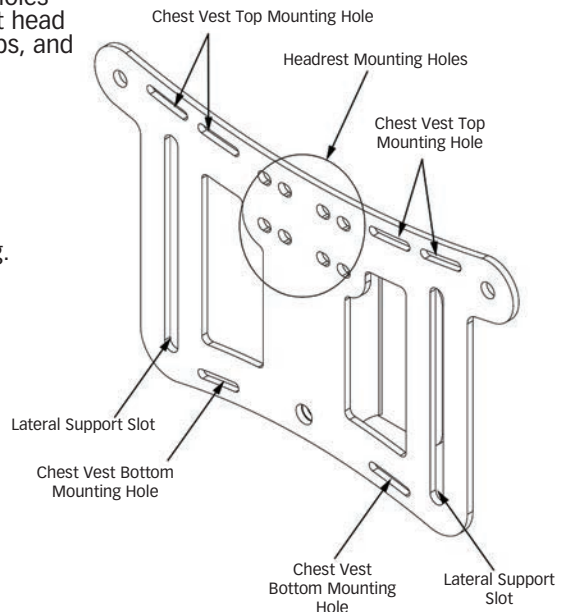
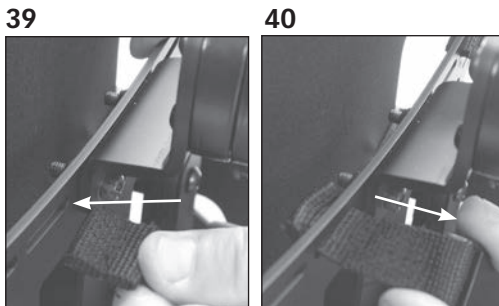

## Controller Usage

Designed with ease of use and the safety and comfort of the user in mind, the Controller as shown is the single point of operation for the supine option.

**41.** The Controller has 3 positions, Sit-to-Stand, Neutral, and Supine.

**42.** There is a spring loaded safety collar (red colored) which prevents inadvertent switching between modes. It must be lifted upward into the shift knob before the mode can be changed.

### Sit-to-Stand Mode

**43.** With the Controller in Sit-to-Stand mode, the stander functions conventionally, with the footrest carrier remaining stationary, always perpendicular to the floor. The seat raises and lowers, hinged at the knee and at the hip, with the backrest remaining approximately perpendicular to the floor, keeping the patients' torso in an upright posture throughout the range of movement.

**Important: All seat depth and following arm adjustments should be made with the Controller in the Sit-to-Stand mode.**

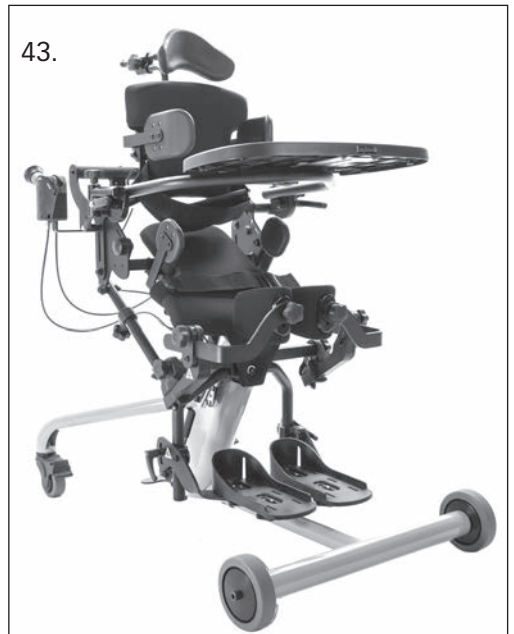

## Controller Usage

### Neutral Mode

44. By lifting the safety collar and moving the shift knob into Neutral position, the footrest carrier and backrest (which are linked through the following arm) now enjoy freedom of movement.

45. The footrest, for the safety of the user, cannot exceed parallel with the seat, nor can knee flexion exceed the lower leg being perpendicular to the floor. With the seat parallel to the floor, the stander may be adjusted into a fully supine position. If the stander is already in the fully standing position, switching to neutral will have no functional effect until the seat begins to lower.

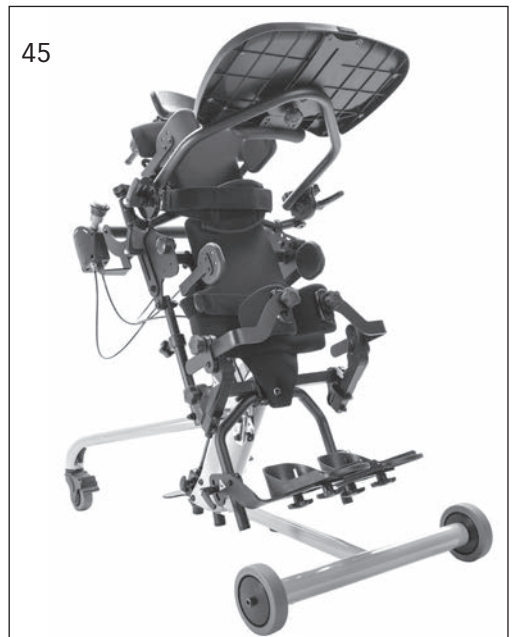

## Controller Usage

### Supine Mode

**⚠ Caution:** A properly fitted and adjusted headrest **MUST** be used with the supine option.

The Bantam with Supine Option functions both as a sit-to-stand stander and a supine stander. It may be safely switched between modes at will, without removing the user from the stander.

If your unit is equipped with a swing-away front it will need to be swung out of the way to reach a full supine position.

**46.** Moving the shift knob to Supine position locks the footrest carrier, seat, and backrest to each other, and will maintain that relationship throughout the possible range of elevation. The now-locked platform may be raised and lowered as necessary by means of the hydraulic pump or Pow'r Up option, however equipped.

**47.** While accommodating the patient in the Supine mode in less than a fully extended position, it must be noted that the overall range of elevation will be decreased by the inverse amount. That is to say, the footrest carrier will never be allowed to move rearward PAST perpendicular to the floor. For Example - If the Supine mode is locked at a position in which the tibia is flexed 20 degrees to the femur, the locked supine platform may not be elevated past a point in which the seat is 20 degrees less than vertical and the footrest carrier perpendicular to the floor. Damage to the unit may result if you attempt to exceed these mechanical limits.

**⚠ Caution:** The locking mechanisms used in the supine option have very high holding power. By familiarity of the feel of the hydraulic pump or the sound of the electric actuator under load in the Pow'r Up option, depending on how the unit is equipped, the operator may be easily aware of the mechanical limits being reached with the supine option. If too great a load is placed on these mechanical locks, damage may result in either the locks or in the frame of the stander. Your warranty does not cover damage from misuse of the product.



## Shadow Tray Adjustment

⚠ **Caution:** These adjustments are only to be made while the unit is in the seated position.

⚠ **Caution:** Always support the tray when loosening the ratchet handles to adjust the tray.

⚠ **Caution:** After placing the tray into position, ensure the ratchet handles on the side of the tray are tightened securely.

### Black Molded Tray and Clear Tray Depth

48. To adjust the depth of the optional tray, place tray tubes into the receptacles and line up holes to the desired depth, and insert pins.

49. To adjust the height of the tray, loosen both ratchet handles on the side of the unit and lift the tray to the user's desired height, tighten securely.

50. To adjust the angle of the tray, loosen both ratchet handles on the side of the tray and position the tray to the user's desired angle, tighten securely.

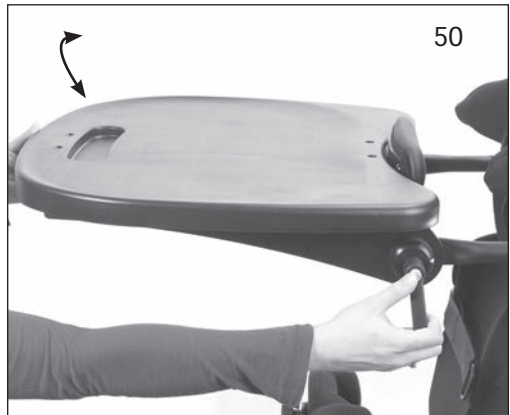

## Swing-Away Shadow Tray Adjustment

### Black Molded/Multi-Adjustable Tray Height

51. To adjust tray height, loosen knobs on the side of unit and set to desired position. Tighten securely

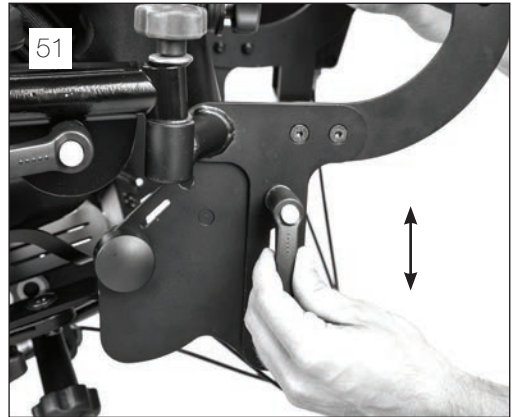

### Multi-Adjustable Tray Depth

52. Loosen knob under the tray, pull or push into desired position. Tighten securely.



### Multi-Adjustable Tray Angle

53. To adjust tray angle, loosen ratchet handles on both sides of the tray, set to desired position. Tighten securely.

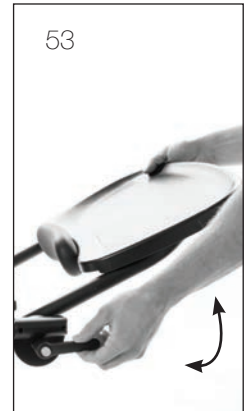

⚠ **Caution:** These adjustments are only to be made while the unit is in the seated position.

⚠ **Caution:** Always support the tray when loosening the knobs or ratchet handles to adjust the tray.

⚠ **Caution:** After placing the tray into position, ensure the ratchet handles on the side of the tray are tightened securely.

### Multi-Adjustable Tray Swing-Away

54. Loosen knob on one side only until you are able to swing tray away. Tray can swing both left and right.



55. Swing tray away to allow for transfers.



Note: To remove tray, loosen knobs on both sides of the tray.



## Head Support Adjustment

**56.** To adjust the head support height, loosen the knob on the back of the back option, move to desired position and tighten securely.

**57A.** To adjust the head support depth, loosen the knob on the back of the headrest and slide into desired position, tighten securely.

**57B.** To adjust the head support angle, loosen the ratchet handle and place into desired position. Tighten securely.

## Foot Plate Adjustment

**58.** Adjust the foot plate by loosening the red ratchet handle on the foot plate, up or down and to the desired angle, tighten securely. Foot plates may be inverted for increased range.



# Pow'r Up Lift Option Usage

## Charging the Battery

The EasyStand Bantam Pow'r Up Lift uses two 12-volt sealed lead batteries rated at 2.9 amps each. An EasyStand Bantam can be lifted approximately 100 times on one full battery charge. An audible alarm will sound when the battery is low. Please charge the battery after the alarm sounds. A battery needing to be fully recharged will take approximately 8 hours. The EasyStand Bantam can be raised to the standing position while being charged. The function of the charger is to detect a full battery and then provide a constant potential power supply to hold the battery at a full condition without overcharging. When the battery EMF rises to a factory preset point, the charger circuit will not allow the peak output voltage to exceed that value. This factory setting protects a battery from excessive depletion of electrolyte, which can occur from overcharging. The charger can be found in the tool pouch on the back of the unit.

**CAUTION:** Use only the Linak charger, model numbers 10CH01S-00, provided by Altimate Medical with the Pow'r Up option.

1. Plug the receptacle into a wall outlet. The light on the charger will be green indicating an open circuit.
2. **FIG. A-** Plug the charger cord into the side of the hand control. The light on the charger will turn yellow indicating the batteries are being charged.
3. **FIG. B-** The unit will arrive unplugged from the battery, plug in the white cord that supplies power to the actuator and the black cord that supplies power to the remote. The black cord has a notch on it to orient the connector properly. Fully charge battery before use.  
*Note:* The white cord has a rubber washer on it, which makes it very sticky and sometimes will not get pushed in completely, make sure to push the cord all the way into the battery.
4. When the batteries are charged, the light on the charger will turn green.
5. Fully charge the batteries every three months or less during periods of intermittent or non-use.

**CAUTION:** The Bantam Pow'r Up Option is not designed for continuous use. Duty Cycle 5% Max, 1 min. / 19 min.

**Raising the Lift** - Press the UP (arrow up) button on the hand control to lift the seat.

**Lowering the Lift** - Press the DOWN (arrow down) button on the hand control to lower the seat.

**CAUTION:** Ensure the cables are attached properly per the instructions for use. Do not allow the cables to drag on the floor or to catch on objects.

**FIG. A**

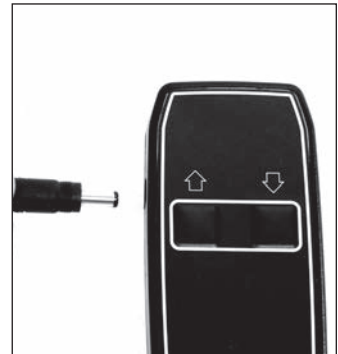

The hand pendant is a Type BF applied part.

**FIG. B**

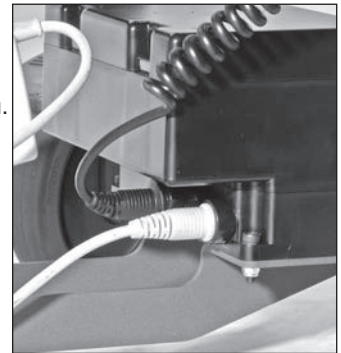

## Activating the Mechanical Emergency Release

**⚠ CAUTION:** Using the emergency mechanical release as the primary means of returning to the seated position can cause damage to the unit. Only use the mechanical release in emergency situations.

All Altimate Medical electric lift products are equipped with a mechanical release to be used in emergency situations.

**FIG. C-**The release allows the user to be lowered to a seated position in the unlikely occurrence of the battery losing charge while the user is in a standing position. The actuator only retracts if the release is pulled and there is weight on the seat. The release is located on the left side of the seat and is signified by a red tag with the word "EMERGENCY."

1. To activate the emergency mechanical release pull out the quick release pin located underneath the seat.
2. Squeeze the handle and if necessary, push down on the handle.



**FIG. C**

## Battery Replacement

The batteries are enclosed in the control box of the Pow'r Up Lift (the black box where the cords are plugged in). Once the batteries have reached their end of life and need to be replaced, do not open the control box; please contact Altimate Medical Customer Service or your medical equipment dealer for information about purchasing a replacement control box. It is recommended that the batteries be replaced every four years.

Please contact a local recycling authority for information about disposing of the old batteries.

## IP Rating

The IP rating is a classification system indicating the protection degree from dust, water and impact for electrical equipment and enclosures. Pow'r Up Lift components are rated at IP21. The definition for IP21 is as follows:

**First character definition:** 2 - Protected against solid foreign objects of 12.5mm diameter and greater.

**Second character definition:** 1 - Protected against vertically falling water drops.

## Electromagnetic compatibility

Pow'r Up Option components have been designed and tested to meet the applicable EMC requirements. It is unlikely that you will encounter problems with your EasyStand due to inadequate electromagnetic compatibility. However, if you notice any unusual (such as intermittent) behavior of your Pow'r Up option and the EasyStand is being used next to possible interfering equipment such as mobile phones, microwaves, or radio broadcast masts, this could be an indication of electromagnetic interference. If such behavior occurs, use the mechanical release to lower the unit to the seated position and move the EasyStand away from the interfering equipment. Please report any instance of possible electromagnetic interference to AMI's Customer Service Department.

## Guidance and Manufacturer's Declaration - Electromagnetic Emissions

The EasyStand Bantam is intended for use in the electromagnetic environment specified below. The customer or the user of the EasyStand Bantam should assure that it is used in such an environment.		
Emissions Test	Compliance	Electromagnetic Environment - Guidance
RF emissions CISPR 11	Group 1	The EasyStand Bantam uses RF energy only for its internal function. Therefore, its RF emissions are very low and are not likely to cause any interference in nearby electronic equipment.  The EasyStand Bantam is suitable for use in all establishments, including domestic establishments and those directly connected to the public low-voltage power supply network that supplies buildings used for domestic purposes.
RF emissions CISPR 11	Class B	
Harmonic emissions IEC 61000-3-2	Class A	
Voltage fluctuations/ Flicker emissions IEC 61000-3-3	Complies	

## Guidance and Manufacturer's Declaration - Electromagnetic Immunity

The EasyStand Bantam is intended for use in the electromagnetic environment specified below. The customer or the user of the EasyStand Bantam should assure that it is used in such an environment.			
Immunity Test	IEC 60601 Test Level	Compliance Level	Electromagnetic Environment - Guidance
Electrostatic Discharge (ESD) IEC 61000-4-2	± 6 kV contact ± 8 kV air	± 6 kV contact ± 8 kV air	Floors should be wood, concrete, or ceramic tile. If floors are covered with synthetic material, the relative humidity should be at least 30 %.
Electrical Fast Transient/Burst IEC 61000-4-4	± 2 kV for power supply lines ± 1 kV for input/output lines	± 2 kV for power supply lines ± 1 kV for input/output lines	Mains power quality should be that of a typical commercial or hospital environment.
Surge IEC 61000-4-5	± 1 kV line(s) to line(s) ± 2 kV line(s) to earth	± 1 kV line(s) to line(s) ± 2 kV line(s) to earth	Mains power quality should be that of a typical commercial or hospital environment.
Voltage dips, short interruptions and voltage variations on power supply input lines IEC 61000-4-11	<5 % $U_T$ (>95 % dip in $U_T$ ) for 0,5 cycle 40 % $U_T$ (60 % dip in $U_T$ ) for 5 cycles 70 % $U_T$ (30 % dip in $U_T$ ) for 25 cycles <5 % $U_T$ (>95 % dip in $U_T$ ) for 5 s	<5 % $U_T$ (>95 % dip in $U_T$ ) for 0,5 cycle 40 % $U_T$ (60 % dip in $U_T$ ) for 5 cycles 70 % $U_T$ (30 % dip in $U_T$ ) for 25 cycles <5 % $U_T$ (>95 % dip in $U_T$ ) for 5 s	Mains power quality should be that of a typical commercial or hospital environment. If the user of the EasyStand Bantam requires continued operation during power mains interruptions, it is recommended that the EasyStand Bantam be powered from an uninterruptible power supply or a battery.
Power frequency (50/60 Hz) magnetic field IEC 61000-4-8	3 A/m	3 A/m	Power frequency magnetic fields should be at levels characteristic of a typical location in a typical commercial or hospital environment.
<i>NOTE: <math>U_T</math> is the a.c. mains voltage prior to application of the test level.</i>			

## Guidance and Manufacturer's Declaration - Electromagnetic Immunity

The EasyStand Bantam is intended for use in the electromagnetic environment specified below. The customer or the user of the EasyStand Bantam should assure that it is used in such an environment.

Immunity Test	IEC 60601 Test Level	Compliance Level	Electromagnetic Environment - Guidance
<p>Conducted RF IEC 61000-4-6</p> <p>Radiated RF IEC 61000-4-3</p>	<p>3 Vrms 150 kHz to 80 MHz</p> <p>3 V/m 80 MHz to 2.5 GHz</p>	<p>3 Vrms</p> <p>3 V/m</p>	<p>Portable and mobile RF communications equipment should be used no closer to any part of the EasyStand Bantam, including cables, than the recommended separation distance calculated from the equation applicable to the frequency of the transmitter.</p> <p>Recommended separation distance</p> $d = 1.2 \sqrt{P}$ <p><math>d = 1.2 \sqrt{P}</math> 80 MHz to 800 MHz</p> <p><math>d = 2.3 \sqrt{P}</math> 800 MHz to 2.5 GHz</p> <p>Where <math>P</math> is the maximum output power rating of the transmitter in watts (W) according to the transmitter manufacturer and <math>d</math> is the recommended separation distance in meters (m).</p> <p>Field strengths from fixed RF transmitters, as determined by an electromagnetic site survey<sup>a</sup>, should be less than the compliance level in each frequency range.<sup>b</sup></p> <p>Interference may occur in the vicinity of equipment marked with the following symbol:</p> <div style="text-align: center;">  </div>

*NOTE 1: At 80 MHz and 800 MHz, the higher frequency range applies.*

*NOTE 2: These guidelines may not apply in all situations. Electromagnetic propagation is affected by absorption and reflection from structures, objects, and people.*

<sup>a</sup> Field strengths from fixed transmitters, such as base stations for radio (cellular/cordless) telephones and land mobile radios, amateur radio, AM and FM radio broadcast and TV broadcast cannot be predicted theoretically with accuracy. To assess the electromagnetic environment due to fixed RF transmitters, an electromagnetic site survey should be considered. If the measured field strength in the location in which the EasyStand Bantam is used exceeds the applicable RF compliance level above, the EasyStand Bantam should be observed to verify normal operation. If abnormal performance is observed, additional measures may be necessary, such as re-orienting or relocating the EasyStand Bantam.

<sup>b</sup> Over the frequency range 150 kHz to 80 MHz, field strengths should be less than 3 V/m.

## Recommended separation distances between portable and mobile RF communications equipment and the EasyStand Bantam.

The EasyStand Bantam is intended for use in an electromagnetic environment in which radiated RF disturbances are controlled. The customer or the user of the EasyStand Bantam can help prevent electromagnetic interference by maintaining a minimum distance between portable and mobile RF communications equipment (transmitters) and the EasyStand Bantam as recommended below, according to the maximum output power of the communications equipment.

Rated maximum output power of transmitter  W	Separation distance according to frequency of transmitter m		
	150 kHz to 80 MHz $d = 1.2 \sqrt{P}$	80 MHz to 800 MHz $d = 1.2 \sqrt{P}$	800 MHz to 2.5 GHz $d = 2.3 \sqrt{P}$
0.01	.12	.12	.23
0.1	.38	.38	.73
1	1.2	1.2	2.3
10	3.8	3.8	7.3
100	12	12	23

For transmitters rated at a maximum output power not listed above, the recommended separation distance  $d$  in meters (m) can be estimated using the equation applicable to the frequency of the transmitter, where  $P$  is the maximum output power rating of the transmitter in watts (W) according to the transmitter manufacturer.

*NOTE 1: At 80 MHz and 800 MHz, the higher frequency range applies.*

*NOTE 2: These guidelines may not apply in all situations. Electromagnetic propagation is affected by absorption and reflection from structures, objects, and people.*

# Options & Parts Detail

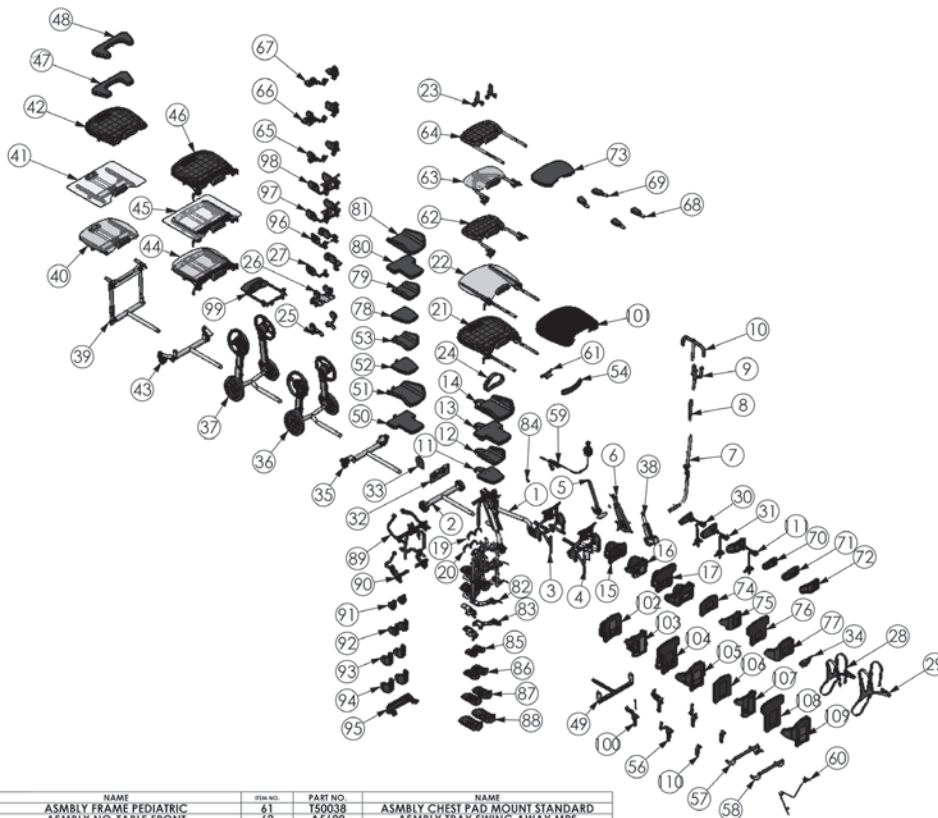

ITEM NO.	PART NO.	NAME	ITEM NO.	PART NO.	NAME
1	T50000	ASMBLY FRAME PEDIATRIC	61	T50038	ASMBLY CHEST PAD MOUNT STANDARD
2	T50016	ASMBLY NO-TABLE FRONT	62	A5600	ASMBLY TRAY SWING AWAY MPFS
3	T50100	BACK REST COMFY XS	63	A5602	ASMBLY TRAY SWING AWAY CLEAR MPFS
4	T50102	ASMBLY BACK REST SMALL	64	T50204	TABLE STANDARD
5	T50018	ASMBLY GAS SPRING PEDIATRIC	65	T50216	LATERALS W/ELBOW STOP
6	T50020	ASMBLY HYDRAULIC LIFT PEDIATRIC	66	T50218	LATERALS W/ELBOW STOP/ARM REST
7	NG50328	HANDLE PUMP REMOVEABLE/ADJ	67	T50220	ELBOW STOP W/ARM REST
8	NG50260	HANDLE STANDARD TOP	68	A5604	ASMBLY FOREARM WINGS MPFS
9	NG50044	QUAD GRIP OPTION	69	A5606	ASMBLY FOREARM WINGS CLEAR MPFS
10	NG50070	ACTUATOR HANDLE EXTENSION EVOLV LG	70	A3035	SLIP COVER HEAD REST XS
11	T50042	ASMBLY SEAT STANDARD XS	71	A3036	SLIP COVER HEAD REST SM
12	T50044	ASMBLY SEAT COMFY XS	72	A3037	COVER HEAD REST CONTOUR SM
13	T50046	ASMBLY SEAT STANDARD SM	73	A3038	PADDED SLIP COVER TRAY MPFS
14	T50048	ASMBLY UPHOLSTRY COMFY SEAT SM	74	T30078	SLIP COVER BACK STANDARD XS
15	T50050	ASMBLY BACK REST STANDARD XS	75	T30079	SLIP COVER BACK COMFY XS
16	T50052	ASMBLY UPHOLSTRY FORM TO FIT BACK XS	76	T30080	SLIP COVER BACK STANDARD SM
17	T50054	ASMBLY BACK REST STANDARD SM	77	T30081	SLIP COVER BACK COMFY SM
18	T50056	ASMBLY UPHOLSTRY COMFY BACK SM	78	T30082	SLIP COVER SEAT STANDARD XS
19	T50080	ASMBLY FOOT STRAP PED	79	T30083	SLIP COVER SEAT COMFY XS
20	T50082	ASMBLY FOOT STRAP SECURE PED	80	T30084	SLIP COVER SEAT STANDARD SM
21	T50074	ASMBLY TABLE STANDARD PEDIATRIC	81	T30085	SLIP COVER SEAT COMFY SMALL
22	T50076	ASMBLY TABLE CLEAR PEDIATRIC	82	T50250	FOOT PLATE STANDARD
23	NG50042	SUPPORT GRIP OPTION	83	T50252	FOOTPLATE MULTI-ADJUST
24	T30066	BELT LAP AND CHEST EXTENDED-ADJ	84	T50253	NON SUPINE ASSEMBLY
25	T50007	ASMBLY HIP GUIDES PEDIATRIC	85	T50254	FOOT HOLDERS EXTRA SMALL
26	T50098	ASMBLY HIP GUIDES XS	86	T50256	FOOT HOLDERS MEDIUM
27	T50008	ASMBLY LATERAL GUIDES PED	87	T50258	FOOT HOLDERS MEDIUM
28	T50086	ASMBLY CHEST VEST XS	88	T50260	FOOT HOLDERS LARGE
29	T50088	ASMBLY CHEST VEST SM	89	T50262	KNEE STANDARD BANTAM
30	T50062	ASMBLY HEAD REST XS	90	T50264	SWING-AWAY KNEES BANTAM
31	T50064	ASMBLY HEAD REST SM	91	T50266	KNEE PADS EXTRA SMALL
32	80809	TOOL FOUCH	92	T50268	KNEE PAD SMALL
33	80246	SEAT ANGLE LOCATOR	93	T50270	KNEE PADS MEDIUM
34	T50128	ASMBLY HIGH NINE CHST VEST BRKT	94	T50272	KNEE PADS LARGE
35	T50116	ASMBLY SWIVEL CASTER BANTAM	95	T50278	CALF PAD SOFT BANTAM
36	T50150	MOBILE OPTION BANTAM	96	T50248	ASMBLY LATERAL GUIDES PED
37	T50177	MOBILE OPTION BANTAM TALL	97	T50274	ASMBLY LATERAL GUIDES FLAT
38	T50022	ASMBLY ELECTRIC LIFT BANTAM	98	T50276	ASMBLY LATERAL GUIDES OFFER FLAT
39	T50192	FRAME FRONT BANTAM SWING AWAY	99	T50246	MOBILE TABLE BANTAM
40	T50144	TRAY ASMBLY CLEAR XTEND MOTION	100	T50014	ASMBLY SHADOW SUPPORT TRAY PED
41	T50146	TRAY ASMBLY O-SIZE XTEND MOTION	101	T30093	PADDED SLIP COVER LARGE TRAY
42	T50148	TRAY ASMBLY BLK XTEND MOTION	102	T50238	ASMBLY BACK REST STANDARD SM
43	T50170	H-FRAME BANTAM SWIVEL WHEEL	103	T50240	ASMBLY UPHOLSTRY COMFY BACK HIGH XS
44	T50188	TRAY ASMBLY CLEAR XTEND MOTION TILT	104	T50242	ASMBLY BACK REST STANDARD SM
45	T50190	TRAY ASMBLY O-SIZE XTEND MOTION TILT	105	T50244	ASMBLY UPHOLSTRY COMFY BACK SM
46	T50186	TRAY ASMBLY BLK XTEND MOTION TILT	106	T30089	SLIP COVER BACK HIGH XS
47	T50156	ASSEMBLY ELBOW PAD XS	107	T30091	SLIP COVER BACK COMFY HIGH XS
48	T50160	ASSEMBLY ELBOW PAD SM	108	T30091	SLIP COVER BACK HIGH SM
49	NG50499	ASSEMBLY BEARING SEAT DEPTH	109	T30092	SLIP COVER BACK COMFY HIGH SM
50	T30040	SEAT COVER STANDARD SM	110	T50282	ASMBLY SWING AWAY HANDLE SUPPORT
51	T30061	SEAT COVER CONTOUR SM	111	T50284	ASMBLY HEAD REST XS
52	T30058	SEAT COVER STANDARD XS	112	Y5636	ASMBLY FOOT STRAP MED BANTAM
53	T30059	SEAT COVER CONTOUR XS	113	Y5638	ASMBLY FOOT STRAP SECURE MED BANTAM
54	T30046	PAD FRONT BANTAM			
55	A5614	ASMBLY GAS SPRING LOCK OUT			
56	T50228	ASMBLY SHADOW SUPPORT TRAY PED			
57	T50212	HANDLE ASSEMBLY SUPINE			
58	T50230	HANDLE ASSEMBLY NON SUPINE			
59	T50234	SUPINE OPTION SMALL BANTAM			
60	T50236	HAND ACUATOR ASSEMBLY			

# Standing

## Contraindications

Standing/weight bearing may not be an option for the following reasons:

If the user has severe contractures or range of motion issues

If the user has severe osteoporosis or brittle bone disease

If the user has postural orthostatic hypotension

If the user has dislocated joints

 **Caution:** Consumers considering a standing program should consult with a qualified physician and medical team to determine what indications or contraindications exist. Clinicians must use best clinical judgment to evaluate the user's needs.

Implementing a standing program must be determined on an individual basis by the user's team (Physician, Physical or Occupational Therapist, Rehab Technology Professional/Supplier and the consumer). Consider all indications and contraindications for each client individually to determine if standing/weight bearing is appropriate for them.

## To Stand

 **Caution:** Always consult with a physician or therapist before starting a standing program.

 **Caution:** Never make adjustments to the EasyStand while a user is in the standing position.

 **Caution:** When lowering the unit from standing to sitting, keep all hands and feet clear of the mechanism beneath the seat.



# Maintenance

## Cleaning/Disinfecting

- Clean the EasyStand Bantam with a mild, non-abrasive disinfectant or soap and water.
- Check the EasyStand at least weekly to ensure all nuts, bolts and adjustable parts are tightened securely, failure to do so may result in parts falling off which may cause a choking hazard for children.
- Do not use bleach or any other bleach-based cleaners on the EasyStand.
- Disinfecting wipes are safe to use on metal and non-porous surfaces.
- Use a damp sponge with mild soap or a mild, non-abrasive disinfectant.
- Spot clean Neoprene with mild soap and water.
- Neoprene covers may be removed and hand washed with water. Air dry the covers. Always use care when removing and replacing the covers.
- Do not dry clean any upholstery items.
- If the EasyStand is being used with one user, clean the EasyStand on a monthly basis or as needed.
- If the EasyStand is being used in a multiple user environment, the EasyStand should be cleaned after each use.

## Urethane Coated Fabrics (Dartex or generic equivalent)

- The recommended cleaning and disinfection instructions should be followed whenever possible to avoid damage to the PU membrane which could lead to premature failure of the cover.
- For superficial dirt, use a disposable wipe and a warm solution of neutral detergent. Do not use abrasive cleaners.
- Disinfect using a 0.1% sodium hypochlorite solution (100ppm chlorine), stronger bleach solutions not recommended.
- Thoroughly rinse any remaining cleaning solution with water and dry fabric before re-use or storage.
- Do not iron.

## Hydraulic Actuator Maintenance

- An initial break-in period of approximately 50-100 full cycles is normal for the hydraulic unit. You may experience a squeaking or a less-than-smooth forward stroke. The very close fit of its mating parts gives each actuator its own break-in "feel" and signature sound.
- If the actuator is leaking oil, call a local EasyStand supplier for a replacement. The serial number on the EasyStand will be needed.
- Do not exert excessive force on the actuator handle or use the actuator handle to move the EasyStand around. This may cause damage to the actuator handle and/or the actuator mechanism and will void any warranty.
- User maintenance is not required or recommended on the hydraulic actuator. Never apply lubricant, household oil, grease, or a similar product to any part of the unit. Some compounds may react with the seals used in the manufacture of this product. This may damage the unit and will void any warranty.
- Do not exceed the rated weight limit.
- If the EasyStand was shipped and exposed to a temperature of less than 50 degrees Fahrenheit, you must allow the hydraulic unit to warm to room temperature before use. Failure to follow this step could damage the unit and render it inoperable.
- Once a standing position is reached, the actuator may settle back one stroke, this is normal.
- It is not always necessary to push the actuator handle all the way back to lower the seat. If difficult to lower the seat, try pushing the handle back in different positions.
- If the unit is in the standing position and unoccupied, it is necessary to apply pressure to the seat of the unit while pushing the actuator handle back.

## Purging The Hydraulic Actuator

The hydraulic actuator on the EasyStand has a high probability of getting air trapped in the internal workings of the unit. This is usually caused by in-transit handling and is quite normal. Please follow the simple steps below, as manual hydraulic systems may never operate properly unless the entrapped air is correctly purged. The unit must be at room temperature for this procedure.

1. Pump the handle until the full extension is reached.
2. Continue pumping the handle slowly for an additional 10 strokes. This will properly purge the system.

# Troubleshooting

**My lower leg length is too short for the stander.**

Invert and swap the foot plates left to right.

**One of the arms on my tray is shorter than the other, is this correct?**

Yes, it is designed so you can line up the longer arm first, then the shorter arm.

**We just received our Bantam and on the tray there is a quick pin to secure the tray in place, but there are two bolts attached on both sides. Am I suppose to use the bolts to secure the tray in place?**

The bolts and nuts are used as a tray depth guide. You can move them to any one of the holes on the tray adjustment arm depending on the person using the unit. To use, remove from the tray, position the tray with the correct depth and then reinstall in the hole closest to the tray top. This will stop the arms at the correct depth so it is easier and quicker when attaching the tray. To secure the tray, there are two quick pins attached to cables on both sides of the unit. Check both sides to make sure both are there. Sometimes, in shipping, they will move around, so at first glance only one side is visible.

**How do I order parts?**

Contact your local supplier and have the serial number ready.

# Limited Warranty

This warranty is extended only to the original purchaser/customer (or supplier non consumer who does not buy or resell). Altimate Medical, Inc., warrants the EasyStand Bantam against defects in materials and workmanship as listed below.

- Steel Frames - 5 year warranty
- Hydraulic Actuator - 2 year warranty
- Upholstered components, plastic pads, rubber parts, painted surfaces, bearings and other parts not specifically identified above - 90 day warranty

Warranty on Electric lift option components is as follows:

- Actuator & Hand Pendant – 2 year warranty
- Control Box & Battery – 90 days
- Battery Charger – 90 days

The warranty period commences for the consumer on the purchase date from the seller/supplier. If the product is rented or otherwise not sold to a consumer, the warranty period commences from the date of original invoice from Altimate Medical. Any product proven to Altimate Medical satisfaction to be defective and within warranty period, shall be repaired or replaced at Altimate Medical's option.

ALTIMATE MEDICAL SOLE OBLIGATION AND YOUR EXCLUSIVE REMEDY UNDER THIS WARRANTY SHALL BE LIMITED TO SUCH REPAIR AND/OR REPLACEMENT. This warranty does not include any labor charges incurred in replacement parts installation. Freight charges to factory are at the expense of consumer to seller. Return freight charges will be prepaid by Altimate Medical. For warranty service, please contact the authorized supplier from whom you purchased your Altimate Medical product. In the event you do not receive satisfactory warranty service, please write directly to Altimate Medical at the address below. Do not return products to our factory without prior authorization.

LIMITATIONS AND EXCLUSIONS: The foregoing warranty shall not apply to serial numbered products if the serial number has been removed or defaced. Products subject to negligence, abuse, misuse, improper operation, improper maintenance, improper storage, or damages beyond Altimate Medical's control are not covered by this warranty, and that evaluation will be solely determined by Altimate Medical. Products modified without Altimate Medical's express written consent (including, but not limited to, modification through the use of unauthorized parts or attachments) are not covered by this warranty. The warranty shall not apply to problems arising from normal wear or failure to follow instructions. The warranty will be void if parts not manufactured by Altimate Medical or parts not complying with original equipment specifications are added to an Altimate Medical product.

THE FOREGOING WARRANTY IS EXCLUSIVE AND IN LIEU OF ALL OTHER EXPRESS WARRANTIES. ALTIMATE MEDICAL SHALL NOT BE LIABLE FOR ANY CONSEQUENTIAL OR INCIDENTAL DAMAGES WHATSOEVER.

Altimate Medical maintains a policy of continual product improvement and reserves the right to change features, specifications, and prices without prior notification. Check with Altimate Medical for latest information.

Altimate Medical, Inc.

## Environmental Issues

After life of the product:

- Recycle in accordance with the recycling codes of your country.
- Recycle all metal parts.
- Plastic parts should be disposed of or recycled according to the directive in your country.
- Please inquire at your local disposal management and recycling center for local codes.
- Return hydraulic actuator or damping cylinder (Pow'r Up only) to Altimate Medical, Inc.



AltimateMedical

EasyStandli

EasyStandli<sup>®</sup> CE  
standing made easy



Standing technology should only be used under the guidance of a physician with recommendations for standing program protocol and any medical precautions. Standing programs should be monitored by the attending therapist. Altimate Medical maintains a policy of continual product improvement and reserves the right to change features, specifications, and prices without prior notification. Check with Altimate Medical for latest information. FORM MBANEX-SMALL 081216 REV A Copyright © 2016 Altimate Medical, Inc. All rights reserved. Printed in the U.S.A.