

# MILANO™

Operation Manual &  
Product Specification



**Seating Matters™**

A curved black arrow points from the text box to the green directional lock tab on the front-left castor.

WANT TO GO STRAIGHT?

Ensure to engage directional  
lock castor at front left of chair

This Operation Manual is frequently updated to ensure safe use of your product. Visit [www.seatingmatters.com](http://www.seatingmatters.com) where you can find a free copy of the most up to date version.

# CONTENTS

- 2. Safety instructions.
- 4. Technical Specification.
- 5. User Guide and Operating Instructions.
- 10. Working Environment.
- 11. Intellectual Property.
- 12. Maintenance and Servicing.

# SAFETY INSTRUCTIONS

All instructions must be read and understood before the product may be used.

## Terminologies

**Patient:** The person sitting in the chair.

**User:** Competent person with responsibility for the persons sitting in the chair as well as the suitability of the equipment for the Patient. The User is responsible for checking the chair for faults during the course of its use.

## Assembly, Installation, Warnings & Hazards.

1. This chair should be fully assembled, all fixings secured and the chair checked for safety by a competent person before use.
2. The User must ensure that the product is in good condition before use (check all nuts and bolts are fastened, fabric in good condition etc). If there are any problems, these must be reported to your Seating Matters provider and corrected before the chair is put into use.
3. Keep all body parts away from the mechanisms under the chair. Repairs and maintenance should only be carried out by fully trained technicians.
4. Exercise care in using the release lever for the reclining mechanisms and adjustments to avoid injury.
5. Pressure ulcer or pressure injury reduction is not a guarantee with this equipment. The User must ensure that the Patient has a period out of the chair after prolonged sitting to raise tissue oxygenation levels. Although the chair offers pressure management, the body tissue still needs time to recover. In many places, local or national guidelines recommend a maximum of 2 hours sitting at any one time. You must also observe Patient specific recommendations and guidelines as set by their health professional with regard to the use of tilt and recline for appropriate pressure management.
6. The product must be used on a level, plain, hard surface with the brakes engaged to avoid it moving during use and to ensure stability. When the chair is not in transit, all the braking castors on the product must be engaged to prevent risk of injury when being used.

7. The product may not be left in an outdoor environment. More information on fabrics and their environment can be found later in this manual.
  8. A competent person, trained in the use of the chair, should make adjustments and set it up according to the User requirements and Patient dimensions before the Patient sits in the chair. Where possible, adjustments should be made when the Patient is not in the chair to avoid injury to the User and Patient.
  9. Ensure there is more than one competent person there when making adjustments to ensure they are correct and safe for the Patient.
  10. If in doubt as to any the adjustments, feel free to contact Seating Matters direct at [technical@seatingmatters.com](mailto:technical@seatingmatters.com).
  11. Under no circumstances must the User or Patient stand or sit on the footplate of the chair.
  12. The chair should not be transported in a vehicle while the Patient is seated on the chair.
  13. This product should not be lifted at any time unless by competent persons trained in such manual handling.
  14. When operating the leg rest and recline features on the chair please ensure there is a 450mm gap around the chair to prevent the back or leg rest coming into contact with a wall or any other object.
  15. On powered options, please ensure that your chair is charged daily.
- Please call your Seating Matters provider if you have any questions on these points.

# MILANO™

## TECHNICAL SPECIFICATION

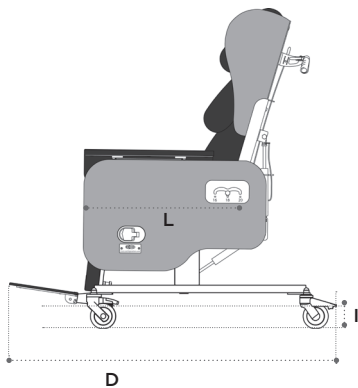
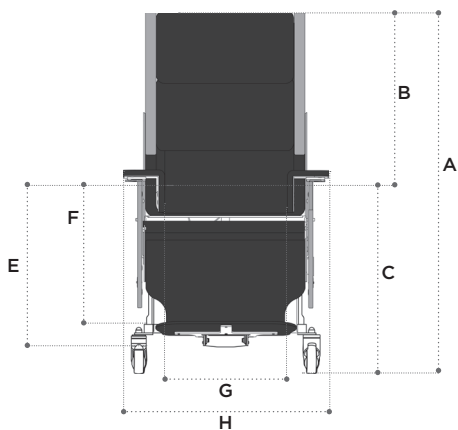

ii

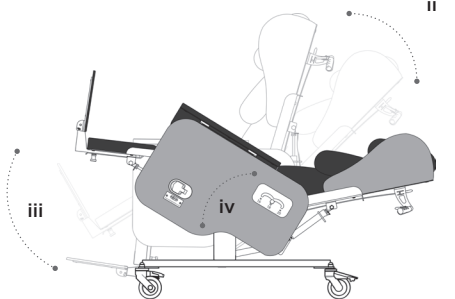

### Basic dimensions.

<b>A</b>	Overall height	1300mm/51in
<b>B</b>	Back height	770mm/30in
<b>C</b>	Seat height	540mm/21in
<b>D</b>	Overall length	930mm/36.5in

### Footplate height adjustments.

<b>E</b>	High	400mm/16in from seat
<b>F</b>	Low	580mm/23in from seat

### Seat depth. (L)

Seat Position 1	400mm/16in
Seat Position 2	450mm/18in
Seat Position 3	500mm/20in

### Available seat and overall width.

G	H
400mm/16in	700mm/27.5in
450mm/18in	750mm/29.5in
500mm/20in	800mm/31.5in

### Clearance Height.

<b>I</b>	130mm/5in
----------	-----------

### Recline and tilt angles.

#### ii Back angle recline

100° - 140°

40° range

#### iii Leg rest angle

Position 1 90° - 160°

Position 2 (Neg Angle) 75° - 145°

From 5° forward, or anterior, tilt to 35° backward, or posterior, tilt.

Chair weight unloaded: 52 Kg / 114lb/ 8 St.

Chair user weight limit: 159 Kg / 364lb / 25 St.

### Boxed delivery dimensions

<b>v</b>	Overall height	1500mm/59in
<b>vi</b>	Overall width	880mm/35in
<b>vii</b>	Overall length	500mm/20in

# USER GUIDE AND OPERATING INSTRUCTIONS



(fig.1)



(fig.1a)

- **Braking castors:** The MILANO™ chair must be used on a plane, hard surface with the brakes engaged to ensure stability and to avoid the device moving undesirably during use. Braking castors, where provided, must be in the braked position while in use (fig.1).



(fig.1b)



(fig.1c)

- **Directional Lock Castor:** The MILANO™ has a directional lock castor to help push the chair straight and minimize sideways movement. Simply engage the green pedal on the front left castor (fig.1b) and it will click lock into a straight position. (fig.1c).

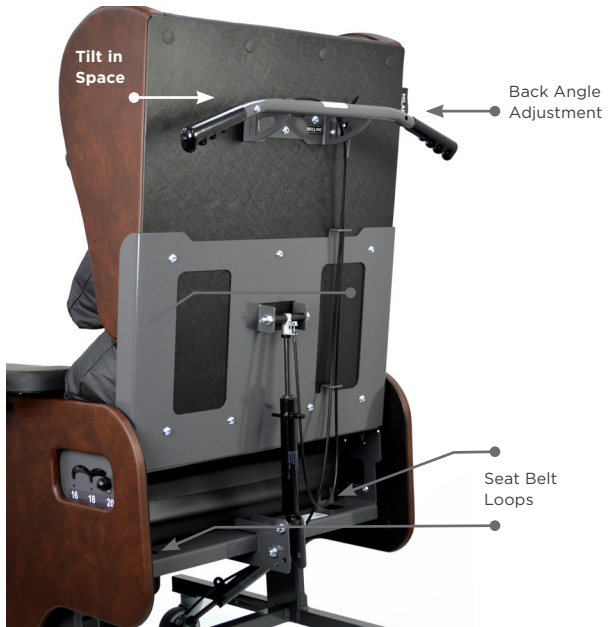

(fig.2)

- **Back angle adjustment:**

To recline the back of the chair, the user must inform the Patient then stand behind the chair, and with two hands, firmly hold the push handle while closing the release lever (fig.2a). Move the back of the chair slowly until it is in the required position and allow the release lever to move to its relaxed position before letting go of the push handles. (fig.2) In powered options, adjustments are performed according to the buttons on the handset.



Back Angle Adjustment

(fig.2a)

- **Tilt in space:** To tilt the chair, the user must inform the Patient then stand behind the chair with two hands, firmly hold the push handle while closing the release lever. (fig.2b) Tilt the chair to the required position then let go of the release lever. In powered options, adjustments are performed according to the buttons on the handset.



Tilt in Space

(fig.2b)



- **Seat depth:** The seat depth is adjusted by moving the back position more forward or back in the chair. To adjust, loosen the locking nut with a 17mm spanner just enough so the safety washer can disengage. Do this on both sides. Then move the back to the more forward or rear position by sliding it through the arched slots.



Seat Depth Adjustment (fig.3)



(fig.3a)

- **Seat width adjustment:** To adjust the seat width, loosen the two grips knobs on the underside of the arm pads (fig.3a). Move the arm pads inwards to reduce seat width and outwards to increase it. Tighten the grip knobs once the desired width has been achieved.



(fig.4)

- **Leg elevation:** Before changing the angle of the elevating leg rest, the User or Patient must ensure there are no objects in the immediate environment that could obstruct the leg rest elevation or come into contact with the Patients legs. Using the manual lever located on the left arm of the chair, move the leg rest to to the required position and allow the manual lever to move to its relaxed position.
- **Footplate height:** The foot plate can be adjusted in height by pulling out the spring plunger, located behind the calfpad of the chair. Once the spring plunger is released it will catch on the next immediate hole position. The footplate can also be completely removed by firstly elevating the legrest and secondly pulling the plunger and sliding the footplate out of its guide bracket.



Footplate height adjustment (fig.4a)



Footplate angle adjustment (fig.4b)

- **Footplate angle:** There are three angle settings on the footplate labelled A, B and C. (fig. XX) To change the angle of the footplate loosen the bolts at each side of the footplate (left and right), remove the bolts, set the footplate to the desired angle (fig.XX) and insert and tighten the bolts in the new bolt hole. Please Note: when getting out of the chair, simply fold up the footplate so that it is parallel with the calf pad. Do not stand on the footplate when getting out of the chair.
- **Negative angle leg rest:** The leg rest on the chair can be set at a negative angle setting for clients with tight hamstrings. See diagram below 5a showing positions A and B . To change the setting loosen the bolt holding the gas strut in place, remove the bolts, move the gas strut to the desired setting and insert and tighten the bolt.

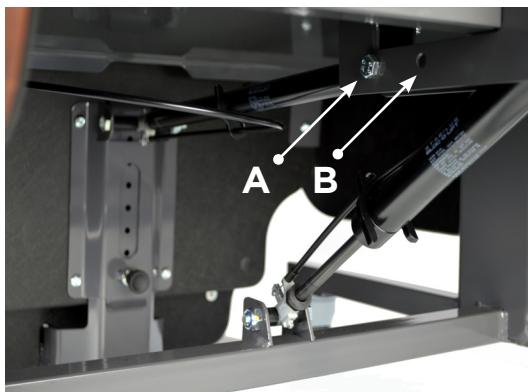

- **Chair movement:** To move the chair around, first ensure that the push handle is in a safe position, the brakes are disengaged. Push using the push handle on the back. Only a competent person should move this chair. Engage the directional lock castor on the front left of the chair to control the direction of the chair and for ease of maneuverability.
- **Seat cushion:** The seat cushion on the MILANO™ is a waterproof, pressure redistributing breathable foam cushion providing pressure management and comfort. The seat cushion has a label saying BOTTOM and BACK. Ensure that this label is placed at the back of the seat base and facing down., with the zip closure at the back and the non-slip material facing down. This is important as the foam's structure allows good immersion and envelopment of the body ONLY when fitted as instructed.

# WORKING ENVIRONMENT

- **Dartex Multi Stretch Fabric:** (Central patient contact surface). Waterproof, stain resistant, flame retardant, multidirectional stretch for pressure redistribution i.e. seat cushion, calf panels, lateral supports and seat back.
- **Vinyl:** (Coloured material on non-patient contact surfaces). Non-absorbent, anti-bacterial, flame retardant, strong, durable material for outer arms, outside back etc.

## Cleaning and Maintenance of Fabrics

- **Vinyl: Stain Resistance:** Vinyl is resistant to urine, most household stains, mild acids/alkalis, drinks and beverages as they are not absorbed and can be wiped off without any problem or lasting damage. Some difficult substances such as lipstick, ball point pen ink and food colourings should be cleaned off immediately to avoid permanent staining.

## Dartex Multi Stretch Fabric (Patient contact surface)

**Properties:** This fabric is waterproof, has the ability to be wiped clean and has biostatic (anti-mycotic) coatings to provide an impenetrable barrier to virus and bacteria. Superficial dirt may be removed by wiping with a soft cloth moistened with water containing a neutral detergent. More persistent contamination may be treated by wiping with alcohols or turpentine substitute, followed by hot water and detergent. Routine cleaning and disinfection may be carried out on the coating with hand hot water and a neutral detergent or with a sodium hypochlorite solution (0.1% or 1000 parts per million available chlorine). The material is compatible with the 10,000ppm available chlorine in solution required for the decontamination of blood spills. Excess solution must be removed and the surface thoroughly rinsed and dried prior to reuse or storage. Proprietary disinfectants may be used provided manufacturer's instructions are followed. All cleaning agents, and disinfectants, must be thoroughly rinsed off and the item dried before storage.

Failure to do this may result in damage to the polyurethane coating, react with the chair frame, or negate the biocompatibility results of the fabric. It is essential that articles be thoroughly dried after all cleaning procedures and before storage.

## End of Life (Disposal)

Please dispose of your chair and any electronic components according to local and national guidelines at the end of its lifespan. Please consider the environment and aim to recycle when possible.

## Safety

Carelessness causes fire. The MILANO™ is CE marked to show conformance to the Medical Devices Directive 93/42/EEC and conforms to BS ISO 7176 at medium hazard.

Filling materials and covering fabrics meet the requirements for resistance to cigarette and match ignition in the 1988 safety regulations.

## Regional Variations

The device referred to as a "MILANO™" is a Seating Matters product category and the information included in this document reflects common features of this group of products. In some regions of the world, we supply product design variations of similar function and ease-of-use but with alternative specifications or reinforcements.

# INTELLECTUAL PROPERTY

Seating Matters are at the forefront of seating research and design, therefore we take the protection of our intellectual property very seriously and have our designs, patents and trademarks protected in many jurisdictions throughout the world. This is a list of some of our Intellectual property protections. This is not an exhaustive list.

- The Seating Matters Trademark is registered throughout the European Union and various countries globally.
- Patent Pending: No. GB1915470.7
- US Design Patent: No. 601360S, No. D611718; No. 600932, No. D602704S.
- Australian Design Registration: No. 325536, No. 324011, No. 325537, No. 324012.
- Community Design Registration: No. 001016364-002, No. 000942180-0004, No. 002428813-0001, No. 001016364-001, No. 012673018.
- Canadian Design Registration: No. 130224, No. 128763, No. 130217, No. 128764.

# MILANO™

## MAINTENANCE AND SERVICING

Regularly servicing your Seating Matters chair will prevent untimely and inconvenient breakdowns, reduce repair costs and extend the chair's life. Damage to the chair can also cause excess strain for the User and Patient.

### Important

Parts can only be changed by service persons trained in Seating Matters products and use only Seating Matters parts. We recommend that your chair is serviced every year by a Seating Matters approved provider for any running repairs and maintenance.

### Maintenance

Carry out the following regular checks to ensure the operation and safety of the chair. If you are in any doubt about the functioning of your chair contact your Seating Matters approved provider immediately.

#### Daily

- Check that the castors are not damaged.
- Check that the castors turn freely.
- Make sure that the castor forks run free and are not bent.
- Check all fabrics for damage or contamination and replace where necessary.
- See Cleaning and Maintenance of Fabrics section for cleaning instructions.
- Check batteries and electrical connections are secure.

#### Weekly

- Check the castor fittings for hair and dirt which could restrict the castor movement.
- Pick out any such material with tweezers or take the spindle out, clean it and then replace it.
- If it is still not free (one continuous turn without it sticking) contact your Seating Matters approved provider for a replacement.

## Monthly

- **Castors:** Make sure the top of the castor housing is parallel with the floor. Any variation will cause restricted movement. If it is damaged contact your Seating Matters approved provider for replacement.
- **Mechanisms:**
  - Check all tilting mechanisms are working smoothly.
  - Check that cables are not kinked or frayed.
  - Check that all nuts and bolts are present.
  - Check that all nuts and bolts are secure.

**Note:** If nuts or bolts need attention, contact your Seating Matters approved provider **IMMEDIATELY** and **DO NOT USE** the chair until it has been serviced.

- **Leg rest:** Check that all leg rests are easily removed/swung-away and replaced or repositioned easily. Ensure that parts lock in place securely. If parts are not locking try lubricating. If the problem still remains contact your Seating Matters approved provider.
- **Frame:** Check the visible parts of the frame for cracks, splits, large dents or other damage. If you find any of these things **DO NOT USE**. Contact your Seating Matters approved provider immediately.

## WE ARE HERE TO HELP

For any questions or queries regarding your Seating Matters chair please contact: [contact@seatingmatters.com](mailto:contact@seatingmatters.com)





## WE ARE HERE TO HELP

For any questions or queries  
regarding your Seating Matters  
chair please email:  
[contact@seatingmatters.com](mailto:contact@seatingmatters.com)







