

Body-Solid

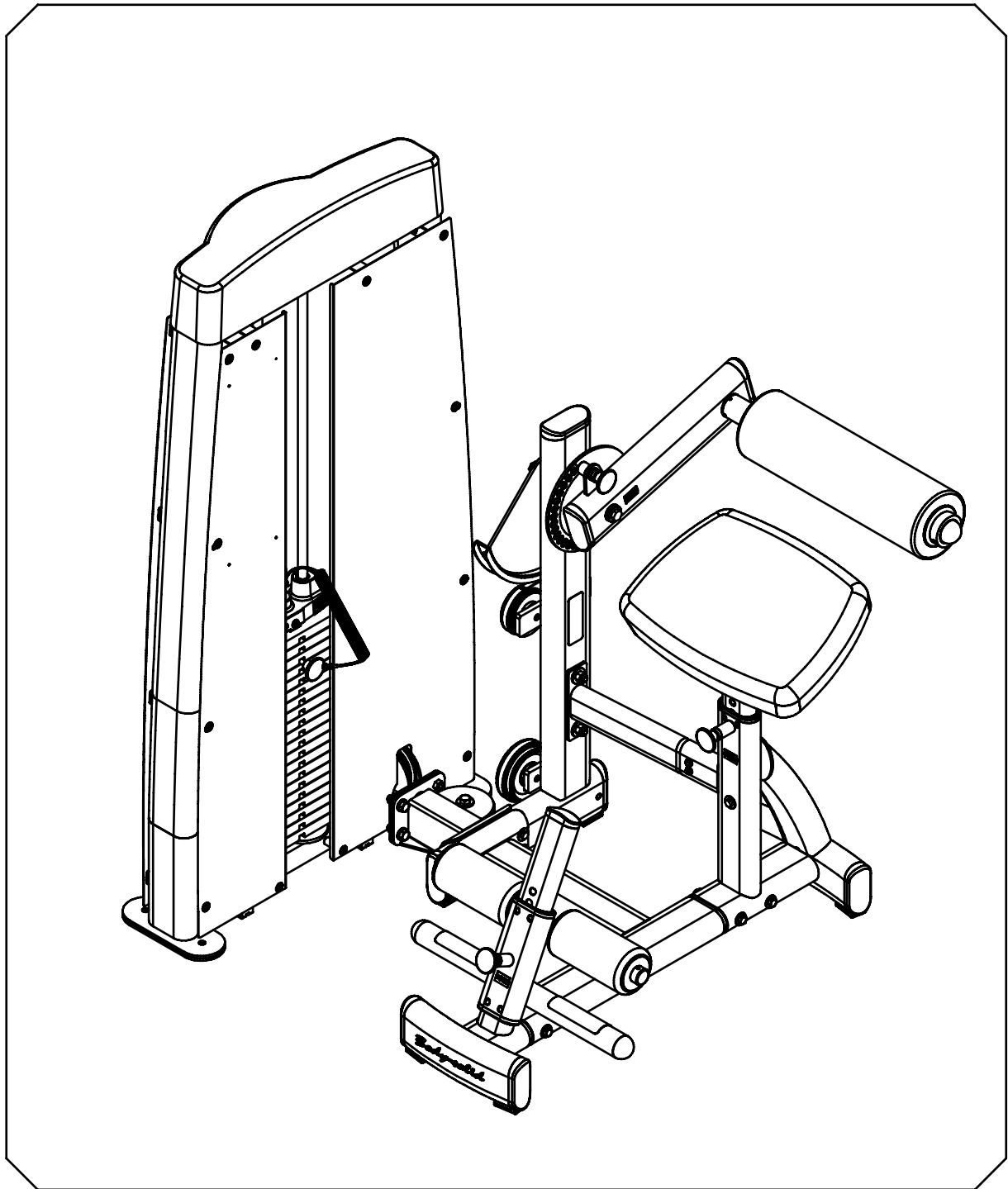

BODY-SOLID, Inc.
1900 S. Des Plaines Ave.
Forest Park, IL 60130 USA
Phone: (708) 427-3555
Fax: (708) 427-3556
www.bodysolid.com

DABB.1 OWNER'S MANUAL

DABB ASSEMBLY INSTRUCTIONS

HARDWARW ILLUSTRATION

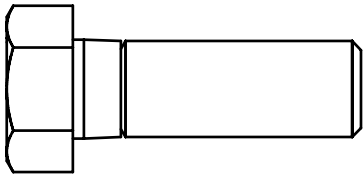

(A1)HEX BOLT 1/2"X1-1/2"L PARTIAL QTY.3

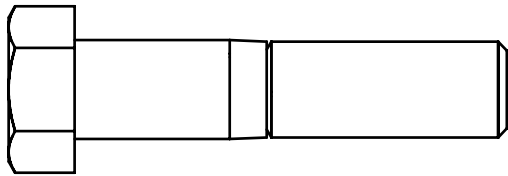

(A2)HEX BOLT 1/2"X2-1/4"L PARTIAL QTY.1

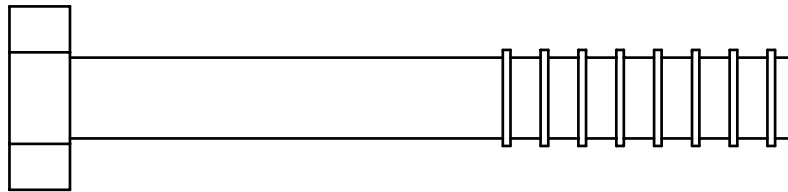

(A3)HEX BOLT 1/2"X3-3/4"L PARTIAL QTY.2

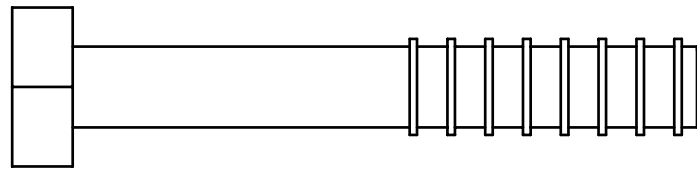

(A4)HEX BOLT 3/8"X3-1/4"L PARTIAL QTY.3

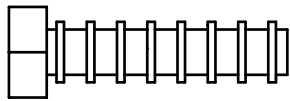

(A5)HEX BOLT 5/16"X1-1/4"L PARTIAL QTY.4

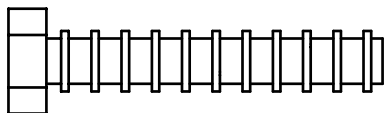

(A6)HEX BOLT 5/16"X1-3/4"L PARTIAL QTY.1



DABB ASSEMBLY INSTRUCTIONS

HARDWARW ILLUSTRATION

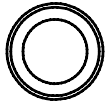

(A7)STEEL BUSHING $\text{Ø}1/2\text{''} \times \text{Ø}8.5 \times 21\text{L}$ QTY.1



DABB ASSEMBLY INSTRUCTIONS

HARDWARW ILLUSTRATION

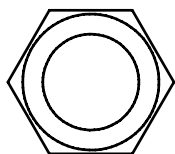
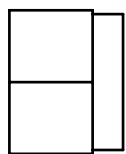

(B1) NYLON LOCK NUT 1/2" QTY.6

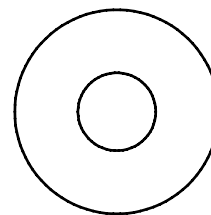

(C3) 3/8" (I.D.) FLAT WASHER Ø27 QTY.6

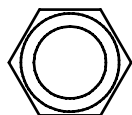
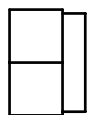

(B2) NYLON LOCK NUT 3/8" QTY.3

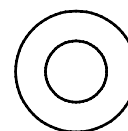

(C4) 5/16" (I.D.) FLAT WASHER Ø16 QTY.2

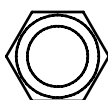
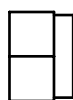

(B3) NYLON LOCK NUT 5/16" QTY.1

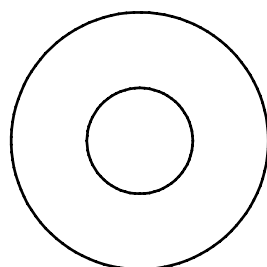
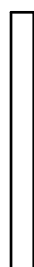

(C1) 1/2" (I.D.) FLAT WASHER Ø34 QTY.6

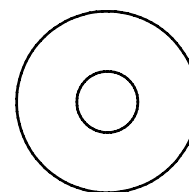

(C5) 5/16" (I.D.) FLAT WASHER Ø24 QTY.4



(C6) SPRING WASHER 5/16" QTY.4

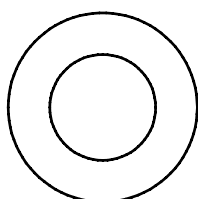

(C2) 1/2" (I.D.) FLAT WASHER Ø25 QTY.6

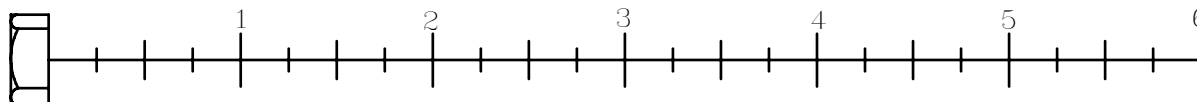

DABB ASSEMBLY INSTRUCTIONS

HARDWARW ILLUSTRATION



(AA1) ALLEN SCREW 5/16"X3/8"L FULL THREAD QTY.3

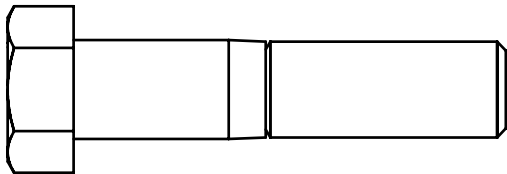

(AA2) HEX BOLT 1/2"X2-1/4"L PARTIAL QTY.3

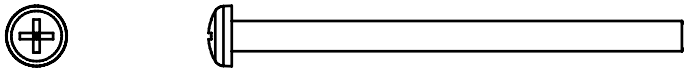

(AA3) ROUND INNER HEX SCREW M4X65L PARTIAL QTY.2

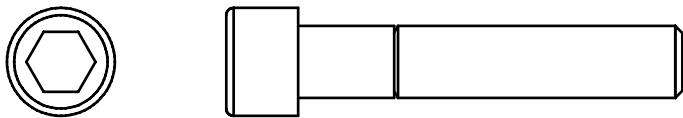

(AA4) ROUND INNER HEAD 3/8"X2"L PARTIAL QTY.1



(AA5) ROUND INNER HEX SCREW M6X20L PARTIAL QTY.20



(AA6) ROUND CROSS SCREW 5/32"X1/4"L PARTIAL QTY.4

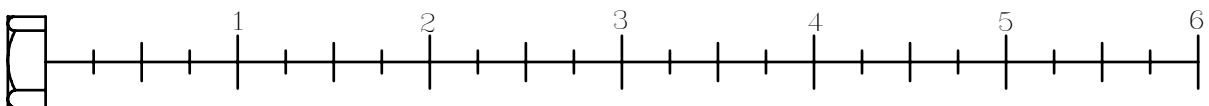

DABB ASSEMBLY INSTRUCTIONS

HARDWARW ILLUSTRATION

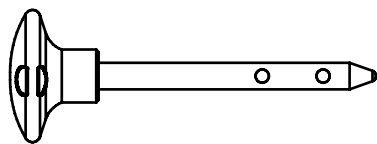

(AA7)10LB PIN(8250-071) QTY.1

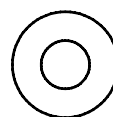

(CC2)M6(I.D.)FLAT WASHER Ø13 QTY.20

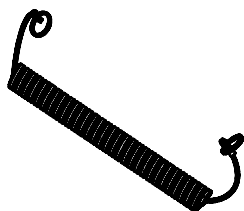

(AA8)ELASTIC BOLT QTY.1

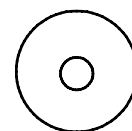

(CC3)M4(I.D.)FLAT WASHER Ø12 QTY.2

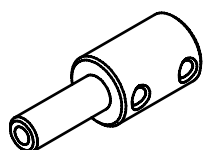

(AA9)WEIGHT STACK CABLE (8260-009) QTY.1

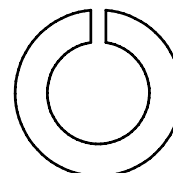
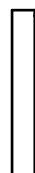

(CC4)SPRING WASHER 1/2" QTY.1

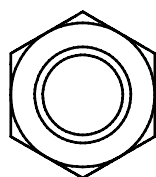

(BB1)NUT 1/2"-13UNC QTY.1

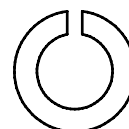

(CC5)SPRING WASHER 3/8" QTY.1

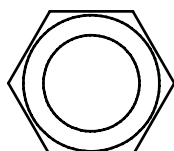
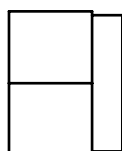

(BB2)NYLON LOCK NUT1/2" QTY.3

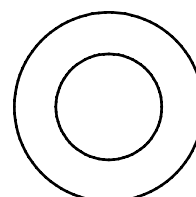

(CC6)1/2"(I.D.)FLAT WASHER Ø25 QTY.2

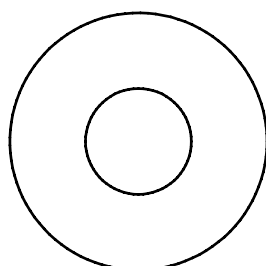

(CC1)1/2"(I.D.)FLAT WASHER Ø34 QTY.4

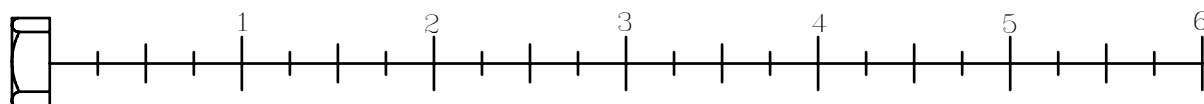

DABB ASSEMBLY INSTRUCTIONS

HARDWARW ILLUSTRATION

- | | | |
|--|--|--|
| | | (D1) $\phi 3/4$ "X13.5X8L STEEL BUSHING(8110-014)-----[2PCS] |
| | | (D2) $\phi 38$ "X $\phi 25.2$ X27L STEEL BUSHING(8130-159) -----[1PCS] |
| | | (D3) $\phi 30$ "X $\phi 20$ X1.5t CU WASHER(8520-007) -----[1PCS] |
| | | (D4) $\phi 38$ "X $\phi 26$ X1.5t CU WASHER(8520-008) -----[1PCS] |
| | | (D5) 95X140L RUBBER PAD(9310-035) -----[2PCS] |
| | | (D6) $\phi 50$ ROUND END CAP(9211-074) -----[3PCS] |
| | | (D7) 50X100 NYLON BUSHING(9211-107)-----[2PCS] |
| | | (D8) 58X116X2.5t FOOT CAP(9211-108) -----[6PCS] |
| | | (D9) 58X116X2.5t END CAP(9211-112) -----[3PCS] |
| | | (D10) 40X80X2t END CAP(9211-113) -----[1PCS] |
| | | (D11) $\phi 4$ " PULLEY(9213-017A) -----[2PCS] |
| | | (D12) $\phi 4$ 1/2" PULLEY(9213-010B) -----[5PCS] |
| | | (D13) $\phi 75$ X3tX $\phi 26$ NYLON WASHER(9214-008) -----[4PCS] |
| | | (D14) $\phi 90$ X $\phi 51$ X3t NYLON WASHER(9214-022)-----[2PCS] |
| | | (D15) 207X105X23 PULLEY CAP(9211-115) -----[1PCS] |
| | | (D16) $\phi 131$ X30 PULLEY CAP(9211-116)-----[1PCS] |
| | | (D17) 3485mm STEEL CABLE -----[1PCS] |
| | | (D18) $\phi 3/4$ " SHAFT COLLAR(9211-046) -----[2PCS] |
| | | (D19) $\phi 4$ "RUBBER DOUNT(9310-017) -----[2PCS] |
| | | (D20) TOP PLATE(8400-006) -----[1PCS] |
| | | (D21) WEIGHT SELECTOR BAR(8210-042) -----[1PCS] |
| | | (D22) 95X250 RUBBER PAD(9310-060) -----[2PCS] |
| | | (D23) DABB FOR DGYM STEEL CABLE(FDABBB) -----[1PCS] |

D1



D2



D3



D4

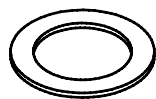

D5

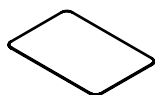

D6

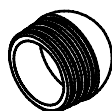

D7

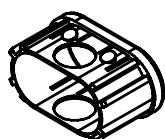

D8



D9



D10



D11

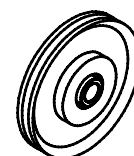

D12

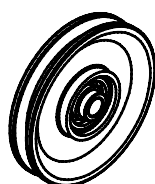

D13



D14



D15

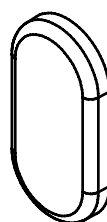

D16



D17

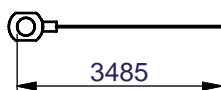

D18



D19



D20

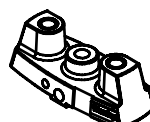

D21

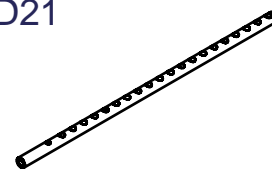

D22



DABB ASSEMBLY INSTRUCTIONS

PARTS ILLUSTRATION

A [1PCS]

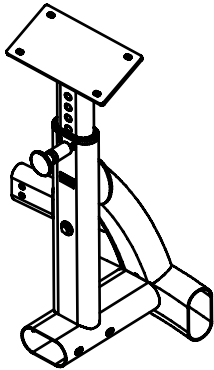

B1 [1PCS]

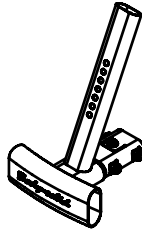

C [1PCS]

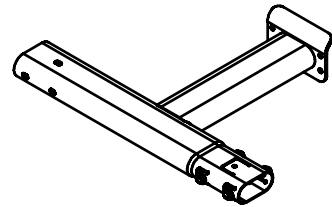

D [1PCS]

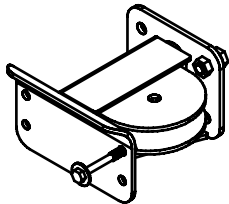

E1 [1PCS]

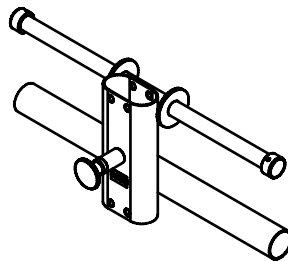

F [1PCS]

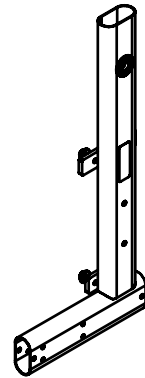

H [1PCS]

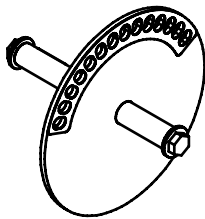

I [1PCS]

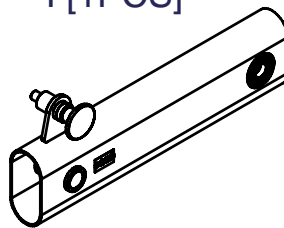

J [1PCS]

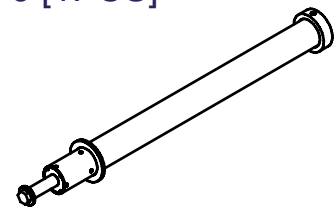

K [1PCS]

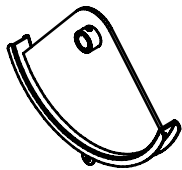

L [1PCS]

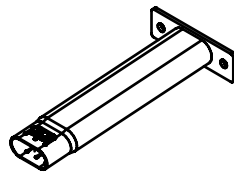

M [1PCS]
8321-091

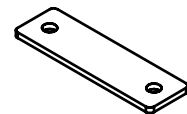

N [1PCS]
9122-039

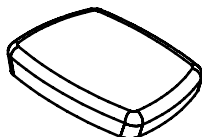

O [1PCS]
9161-047

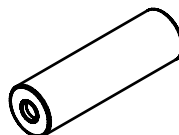

P [2PCS]
9161-032

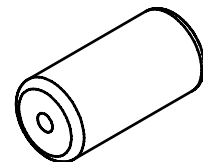

Q [1PCS]
9440-163

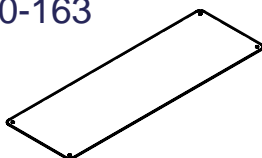

DABB ASSEMBLY INSTRUCTIONS

PARTS ILLUSTRATION

AA[1PCS]
6610-002

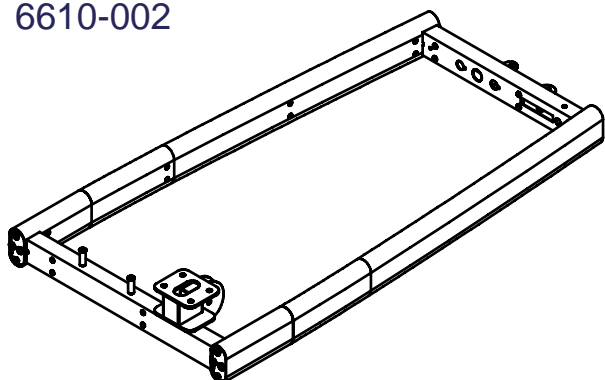

AB[1PCS]
8380-046

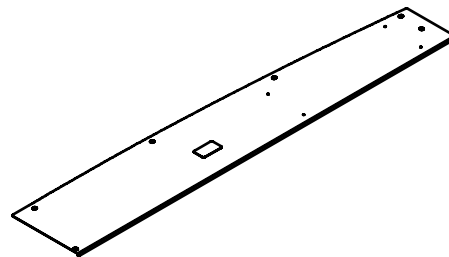

AC[1PCS]
8380-047

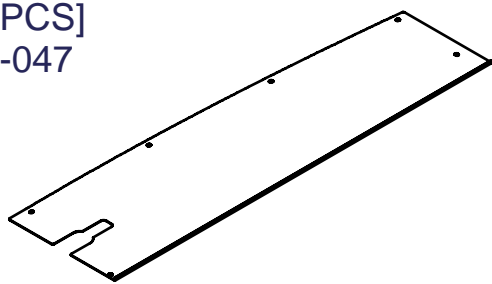

AD[1PCS]
8380-048

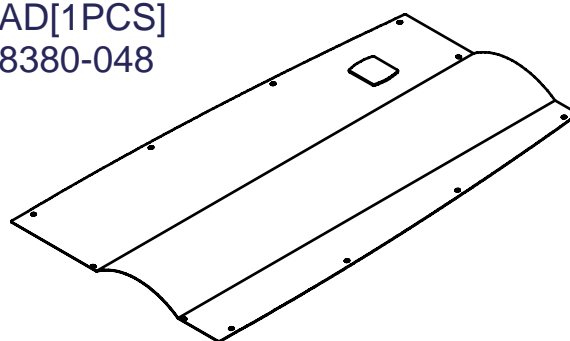

AE[2PCS]
260158A \varnothing 3/4"X1.6tX1407L



AF[1PCS]
9211-111

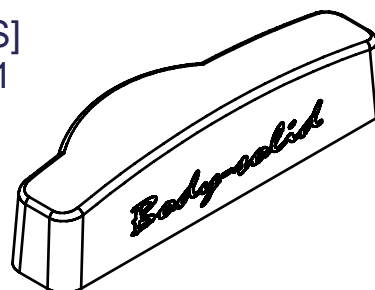

AG[2PCS]
8313-144

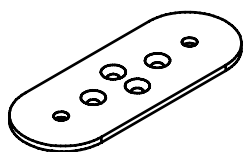

AH[9PCS]
8321-040

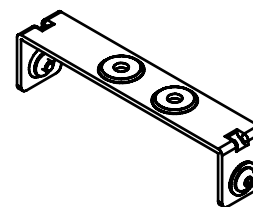
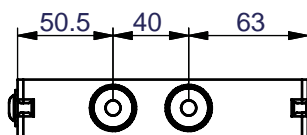

AI[1PCS]
8321-040

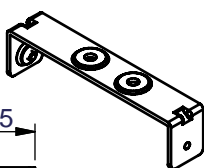
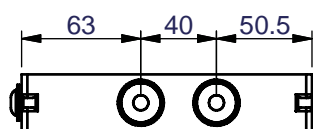

AJ[2PCS]
8321-040

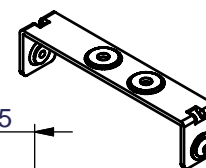
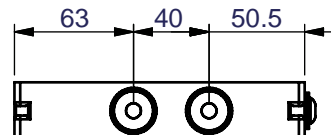

DABB ASSEMBLY INSTRUCTIONS

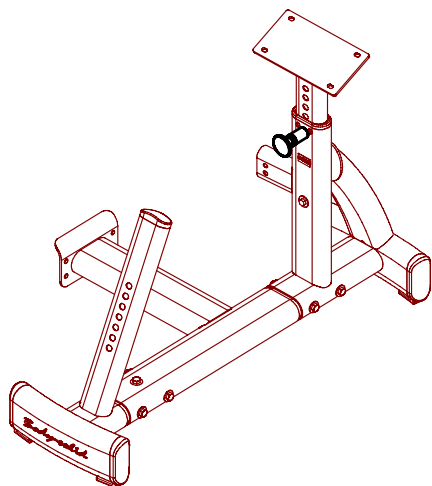

Above shows STEP 1
assembled and completed

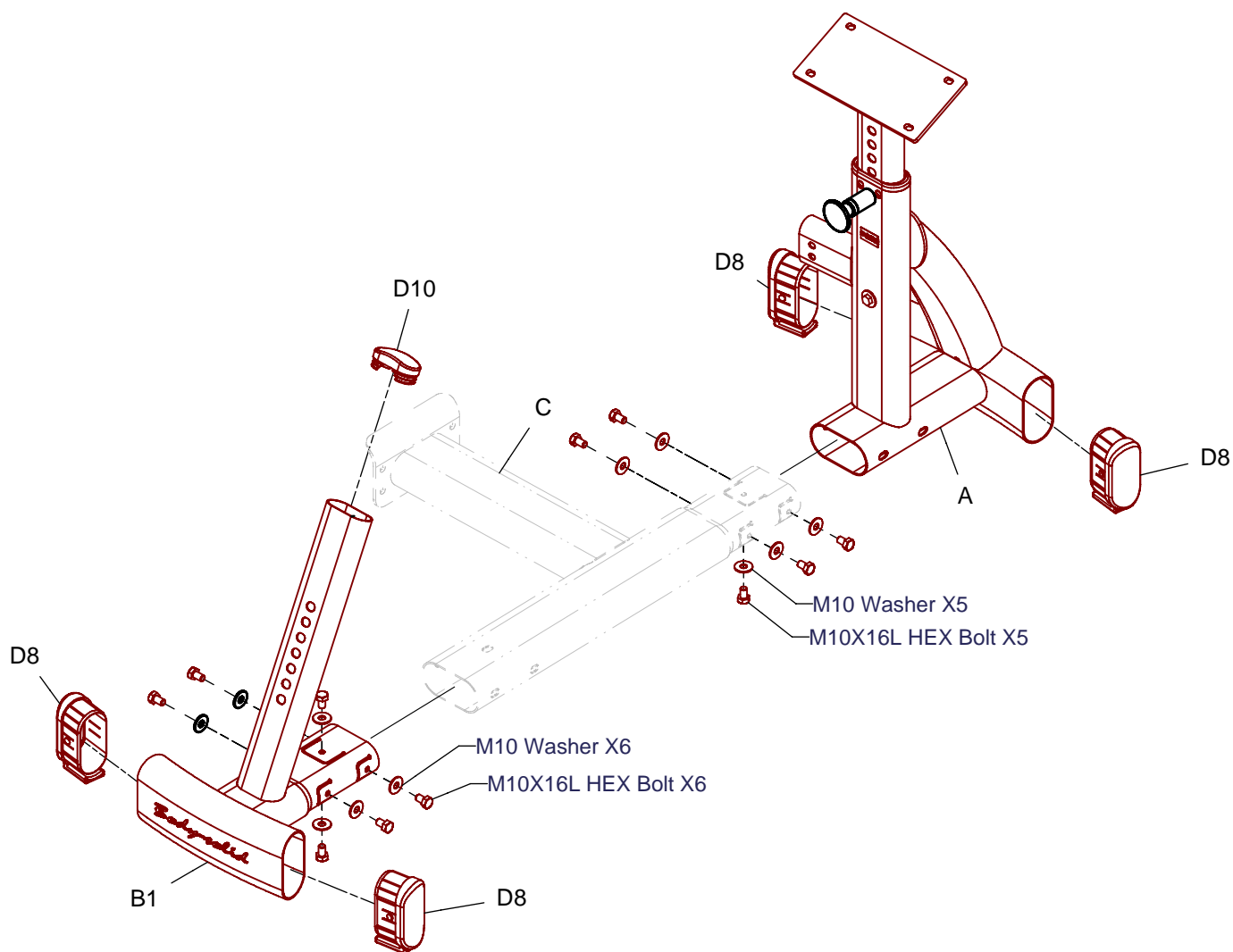

DABB ASSEMBLY INSTRUCTIONS

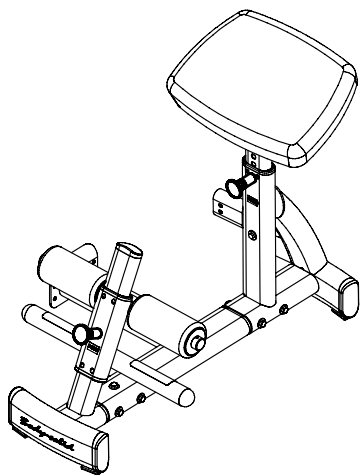

Above shows STEP 2
assembled and completed

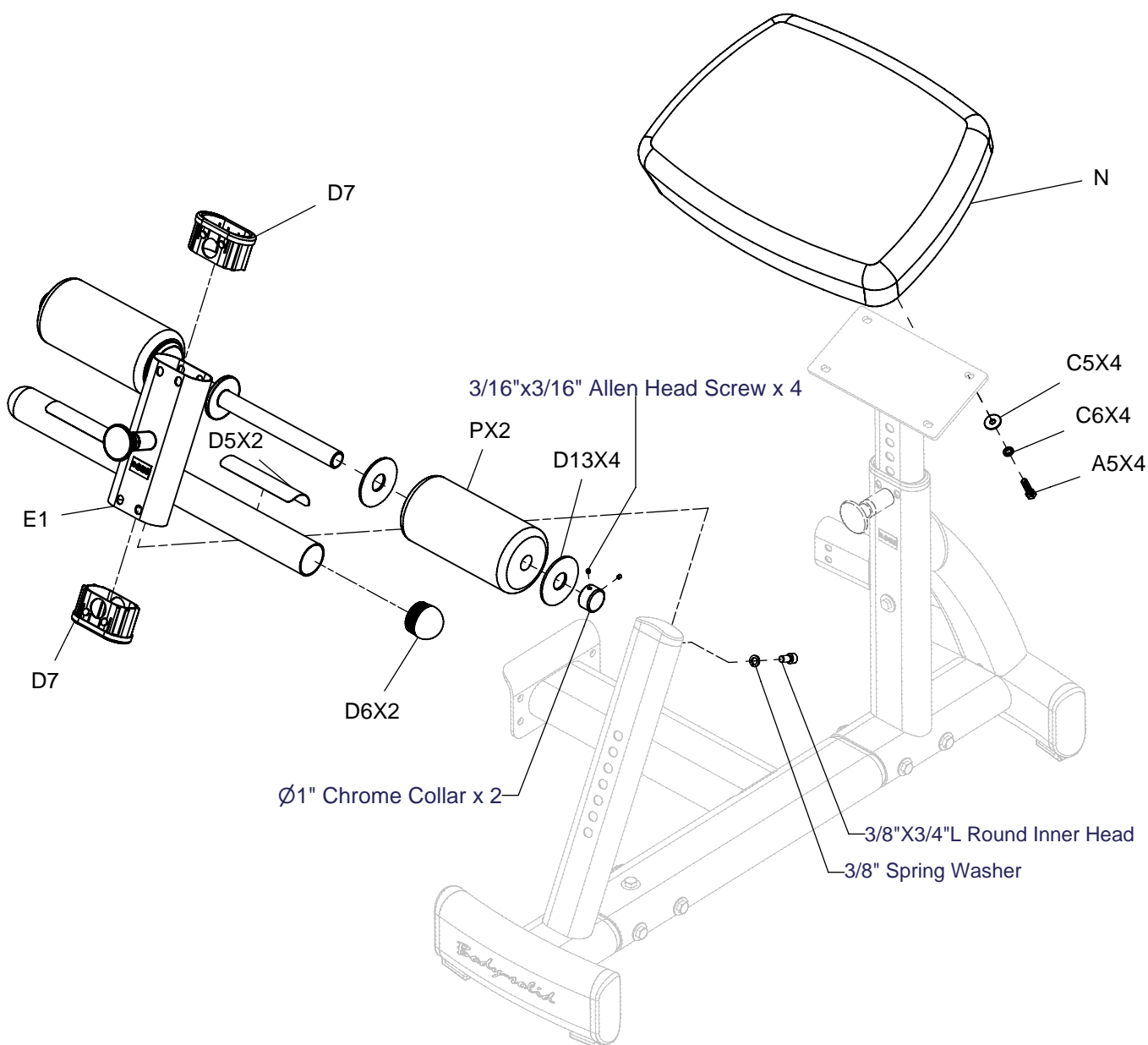

DABB ASSEMBLY INSTRUCTIONS

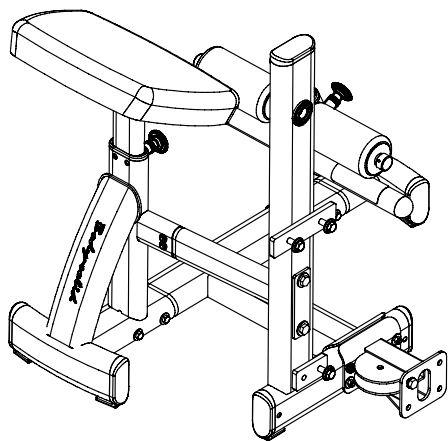

Above shows STEP 3
assembled and completed

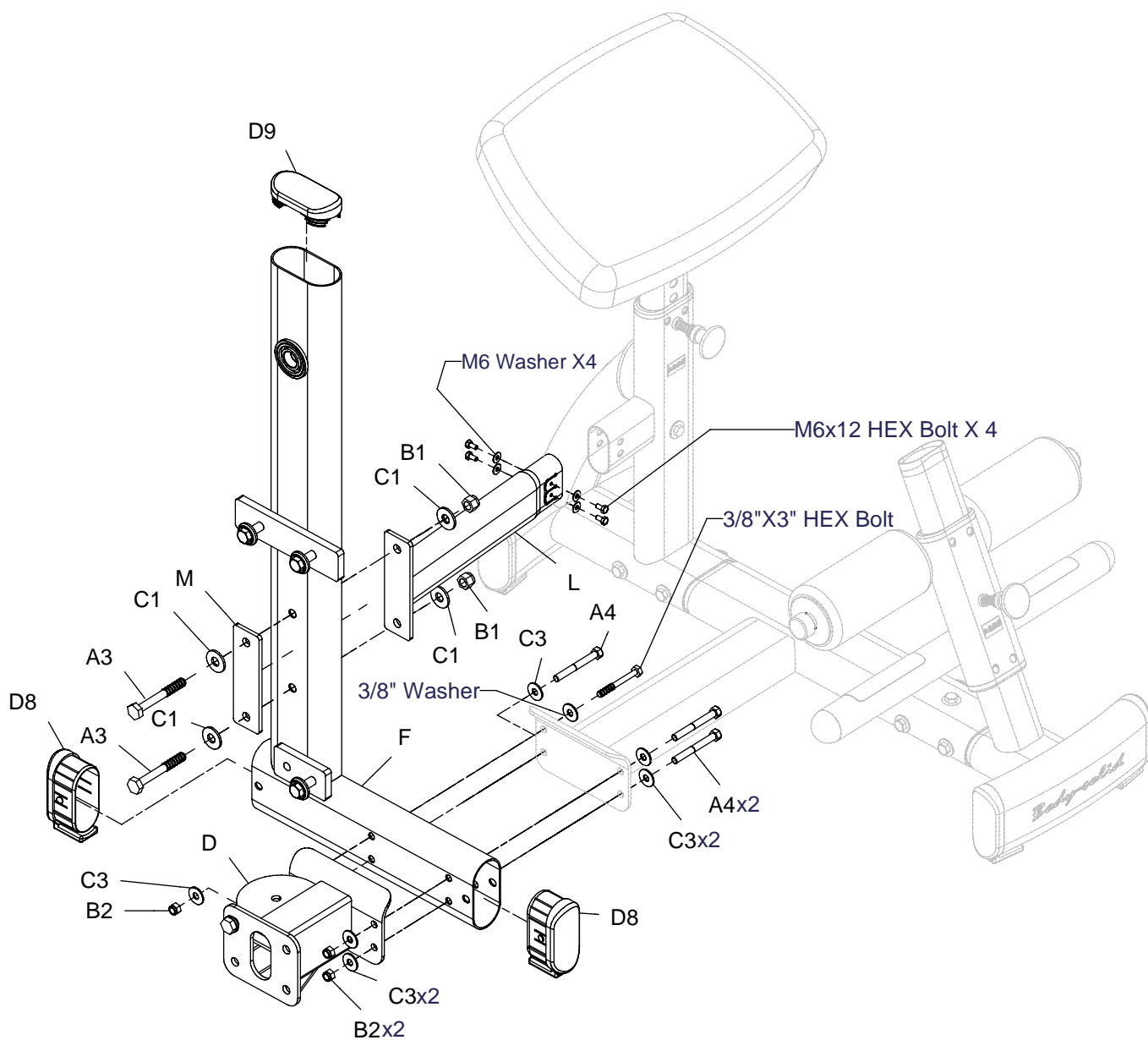

DABB ASSEMBLY INSTRUCTIONS

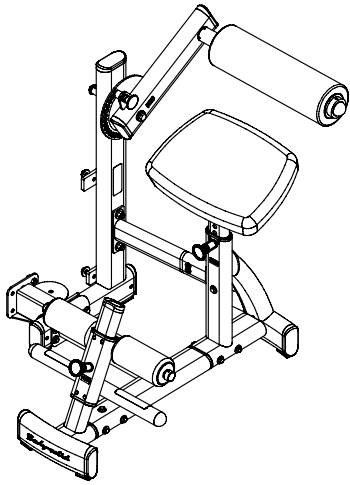

Above shows STEP 4 assembled and completed

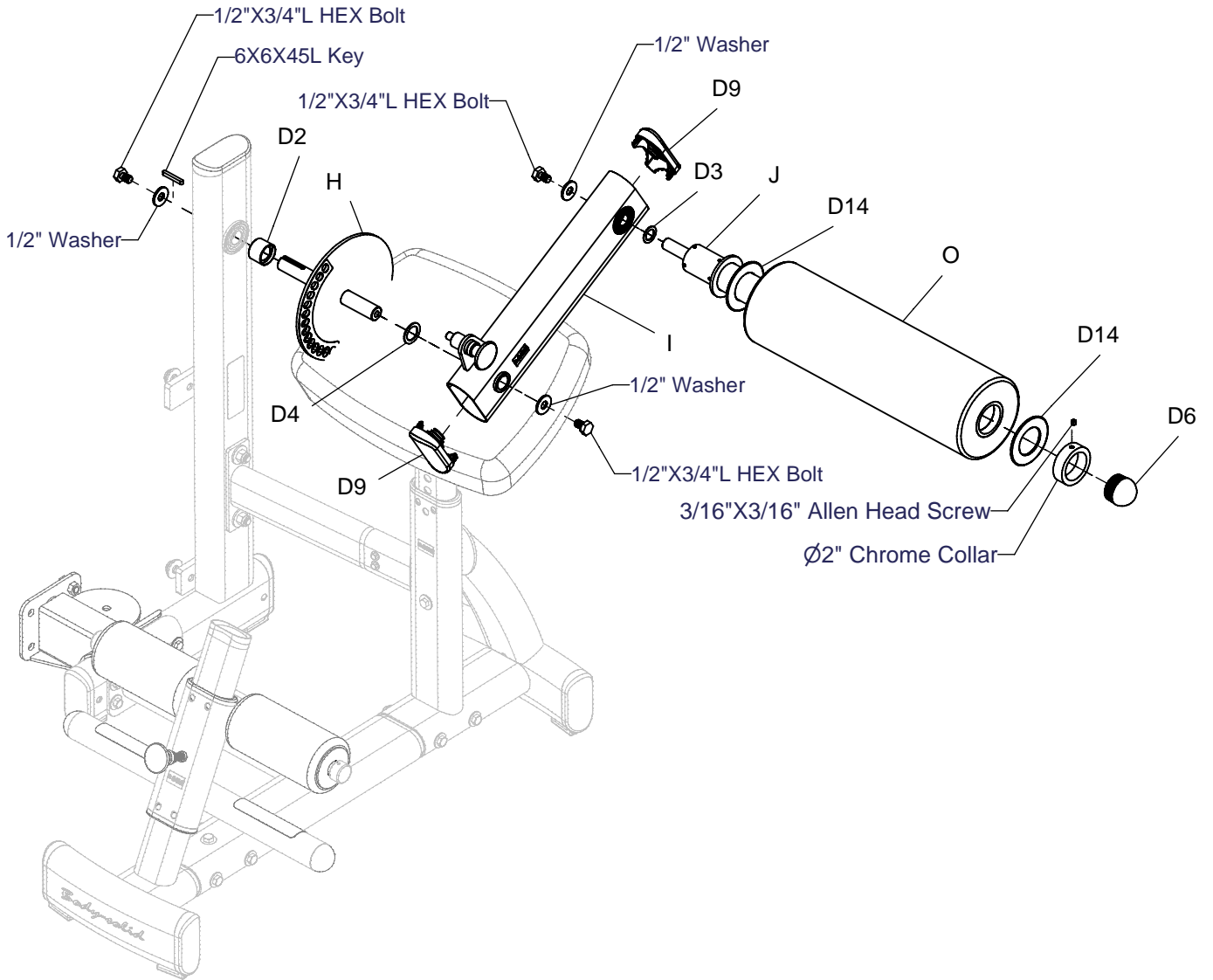

DABB ASSEMBLY INSTRUCTIONS

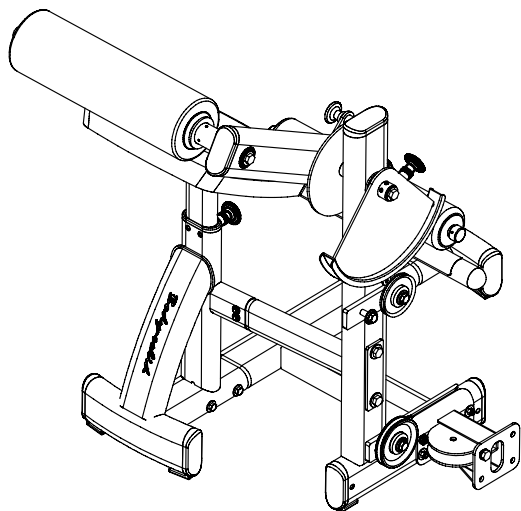

Above shows STEP 5
assembled and completed

Detail View

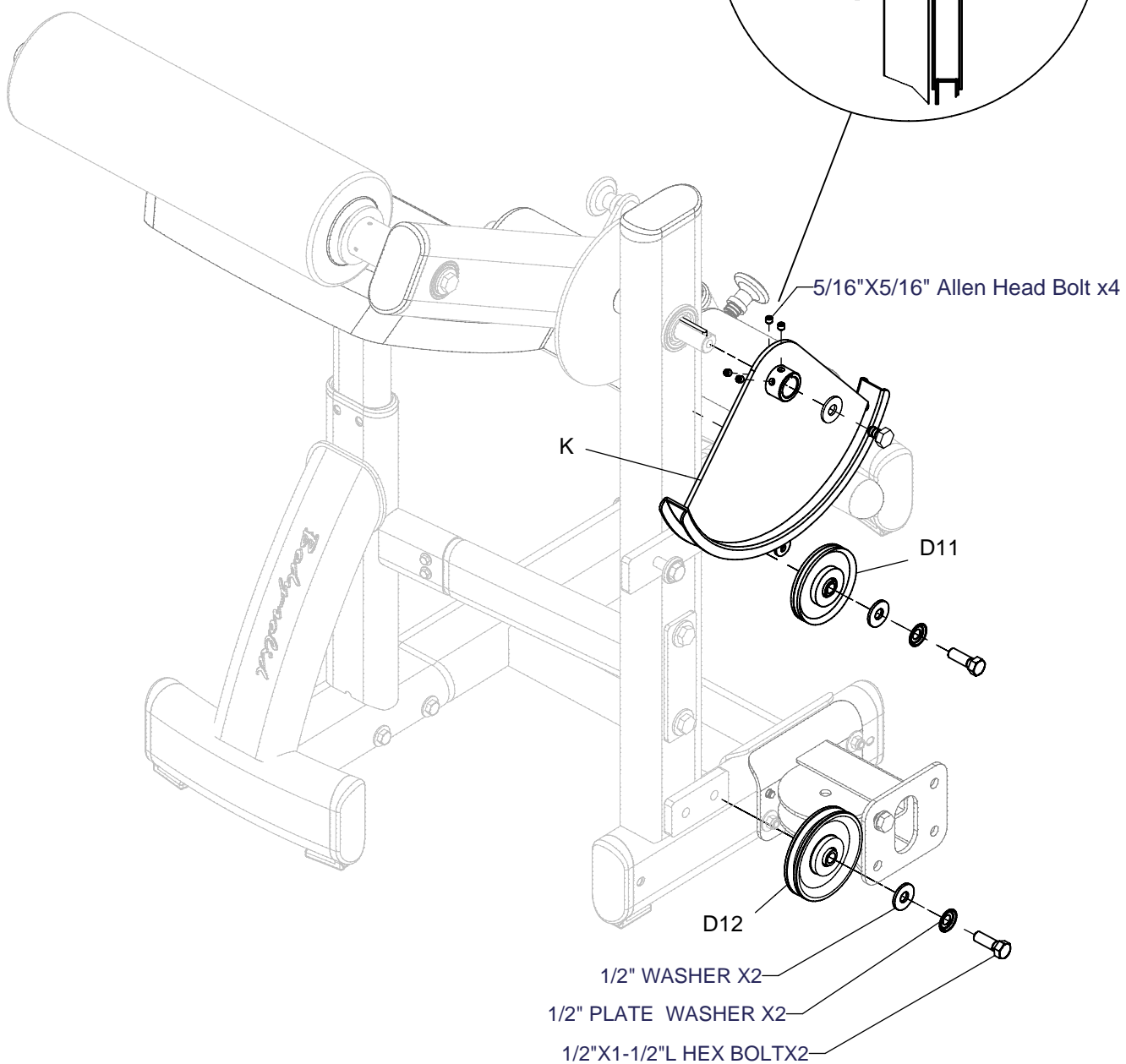
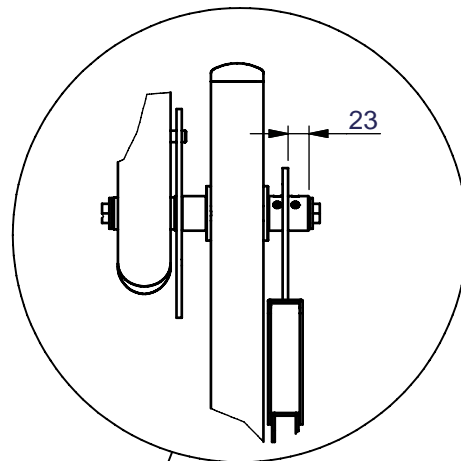

DABB ASSEMBLY INSTRUCTIONS

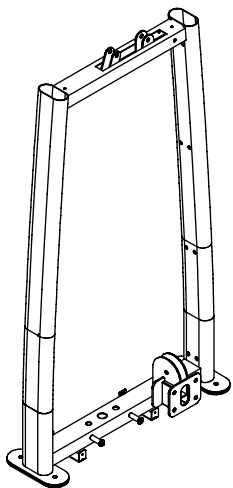

Above shows STEP 6
assembled and completed

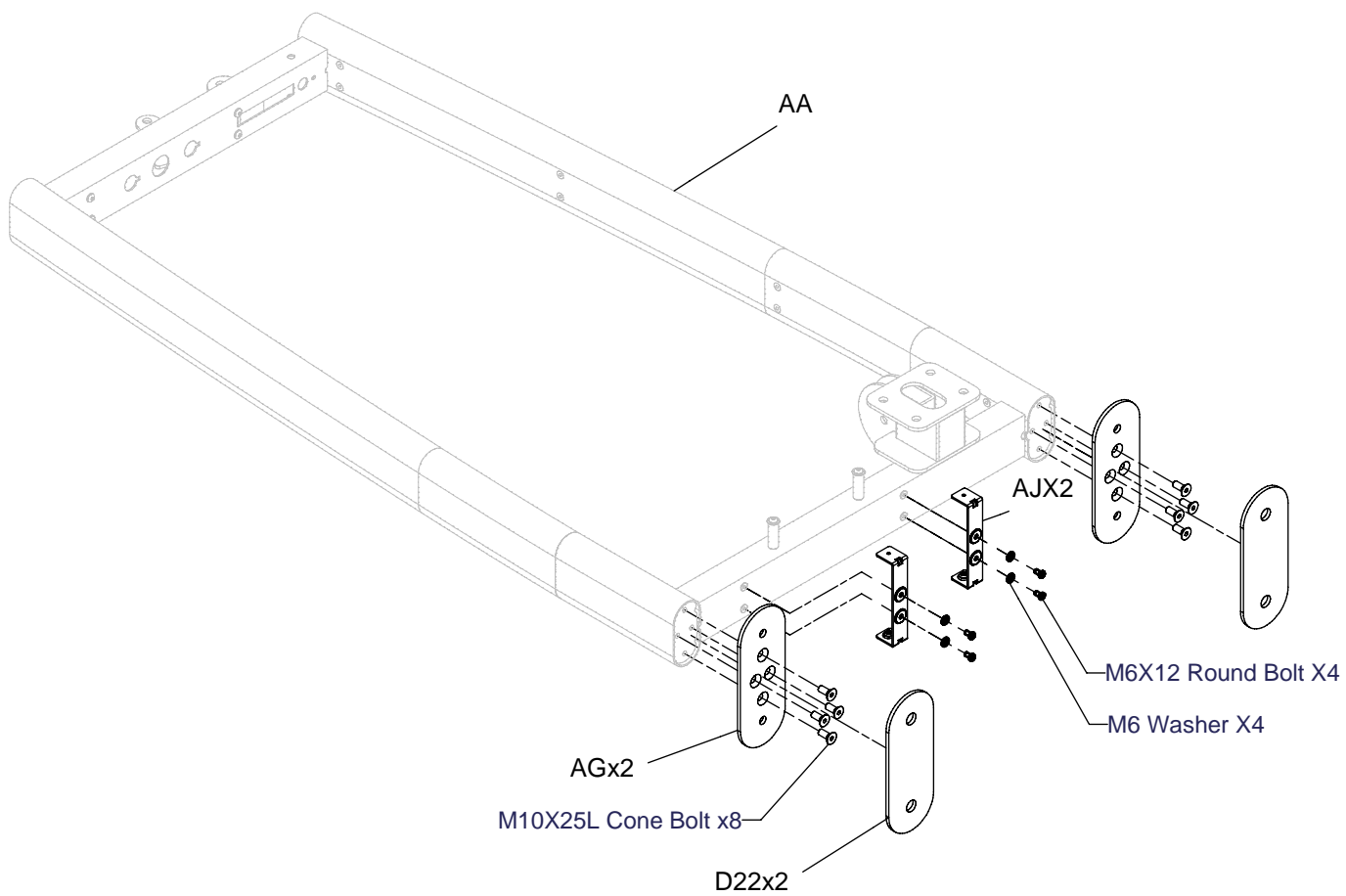

DABB ASSEMBLY INSTRUCTIONS

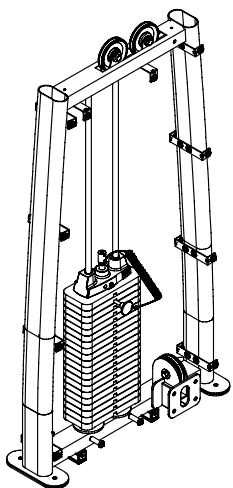

Above shows STEP 8 assembled and completed

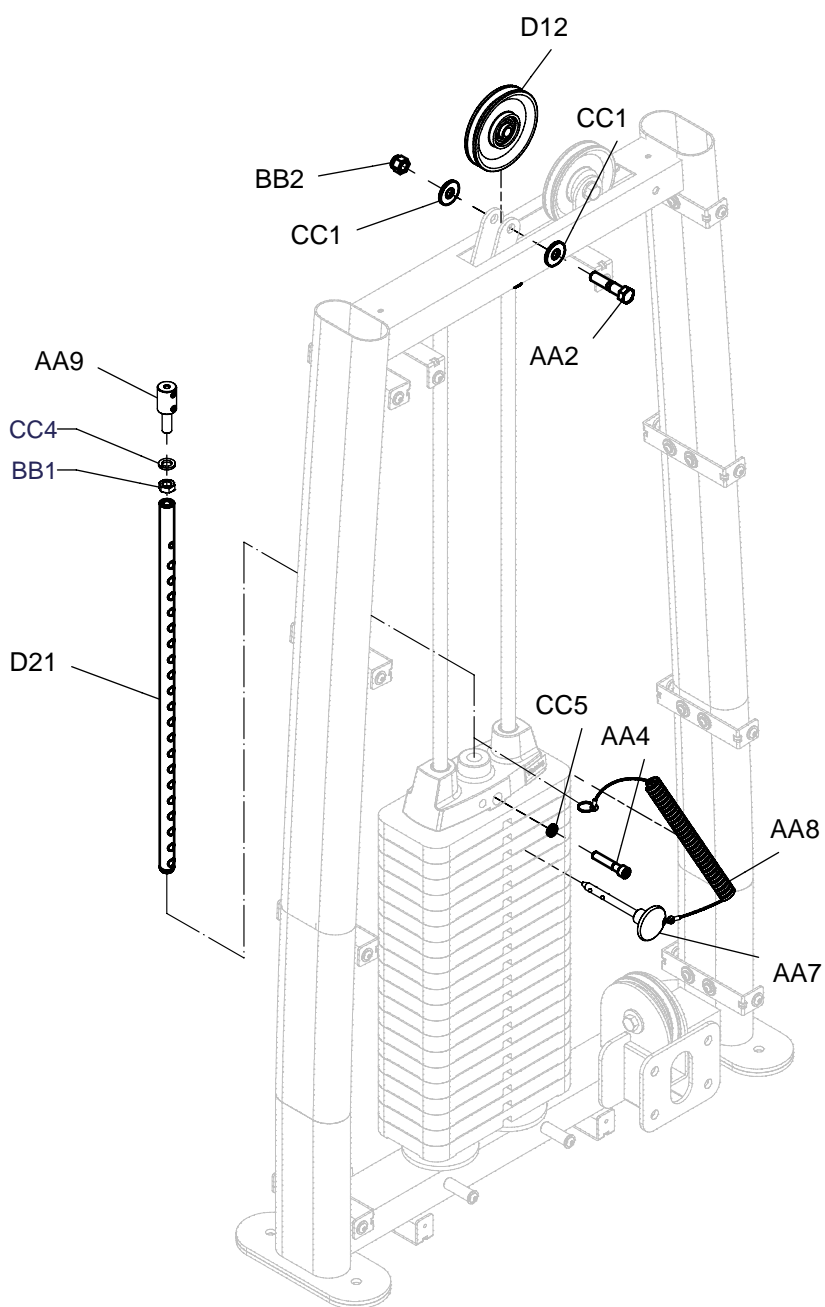

DABB ASSEMBLY INSTRUCTIONS

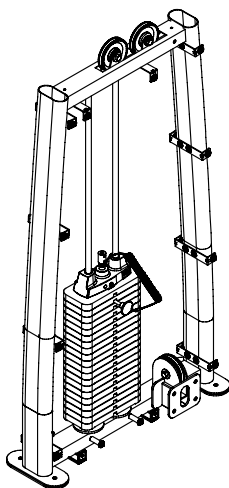

Above shows STEP 8 assembled and completed

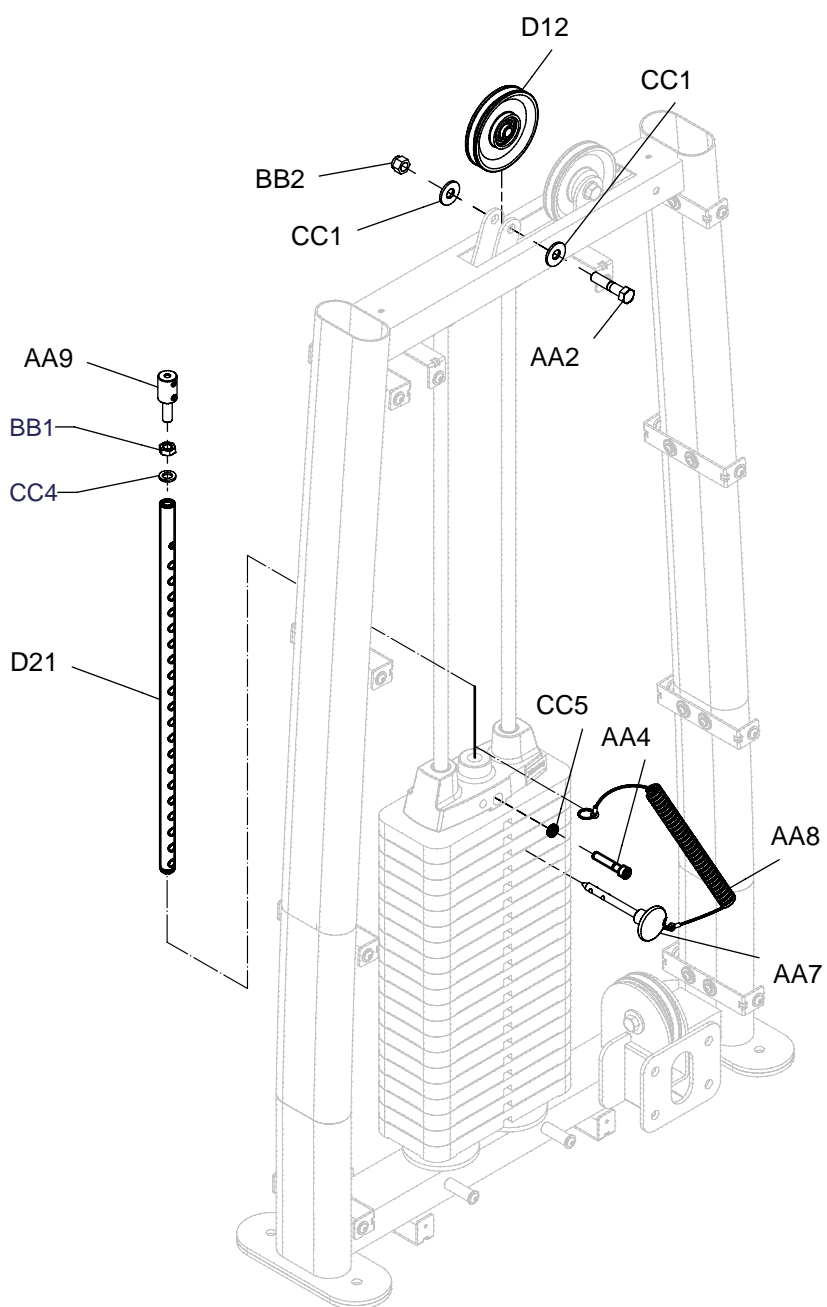

DABB ASSEMBLY INSTRUCTIONS

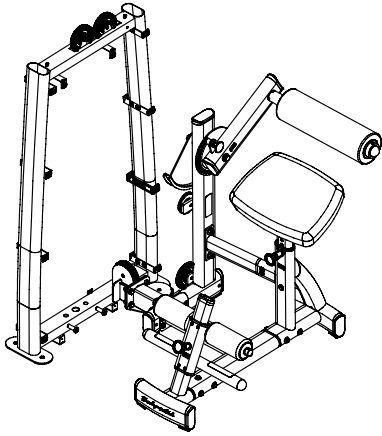

Above shows STEP 9
assembled and completed

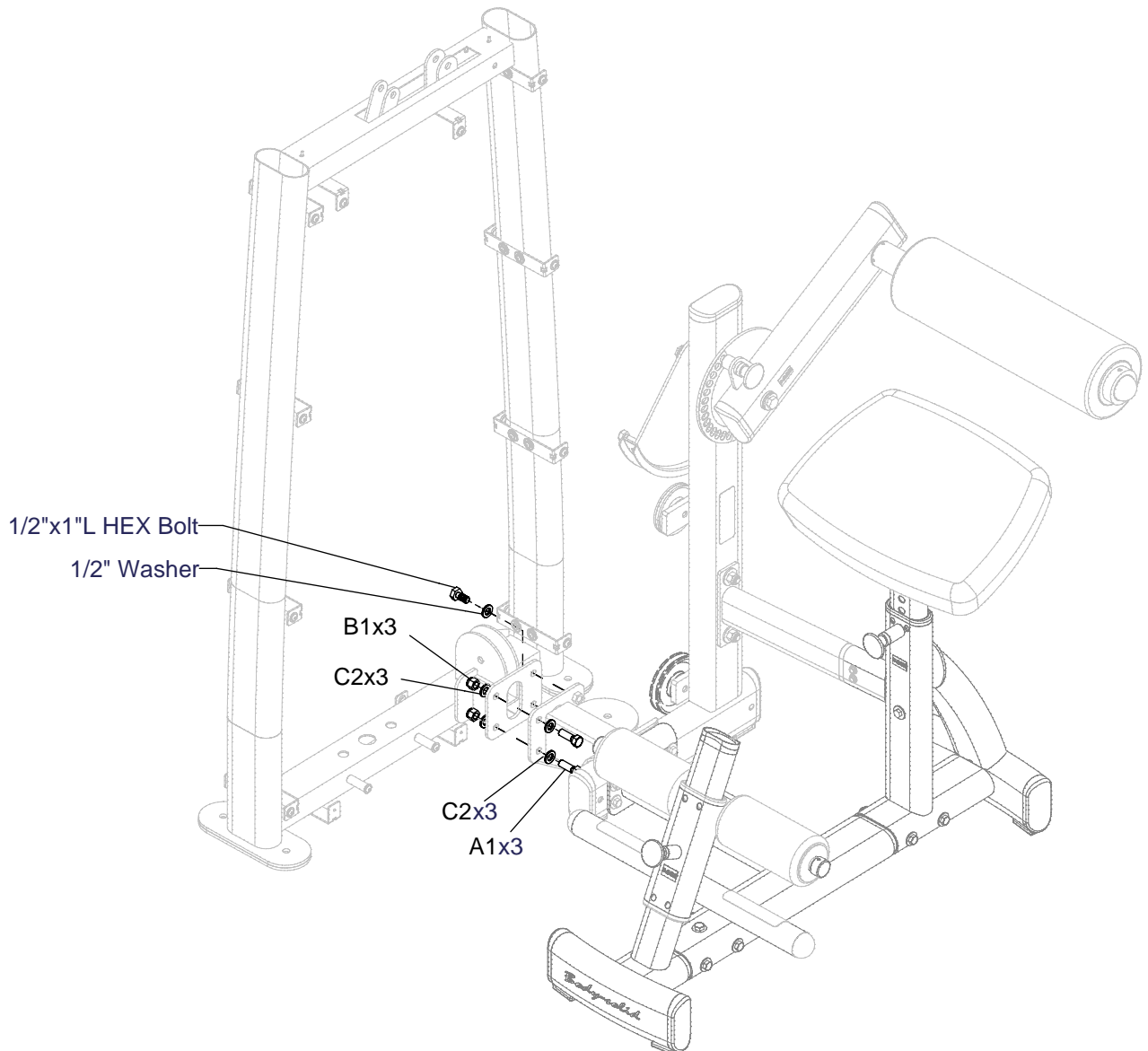

DABB ASSEMBLY INSTRUCTIONS

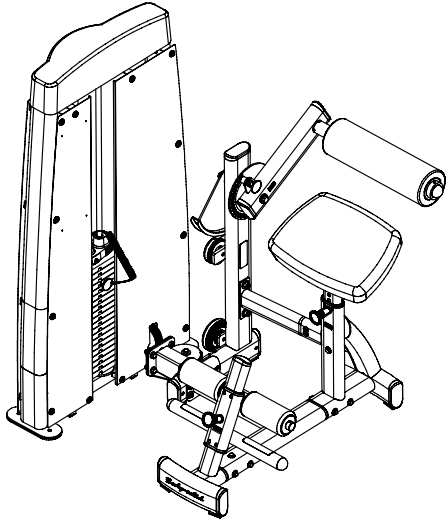

Above shows STEP 10 assembled and completed

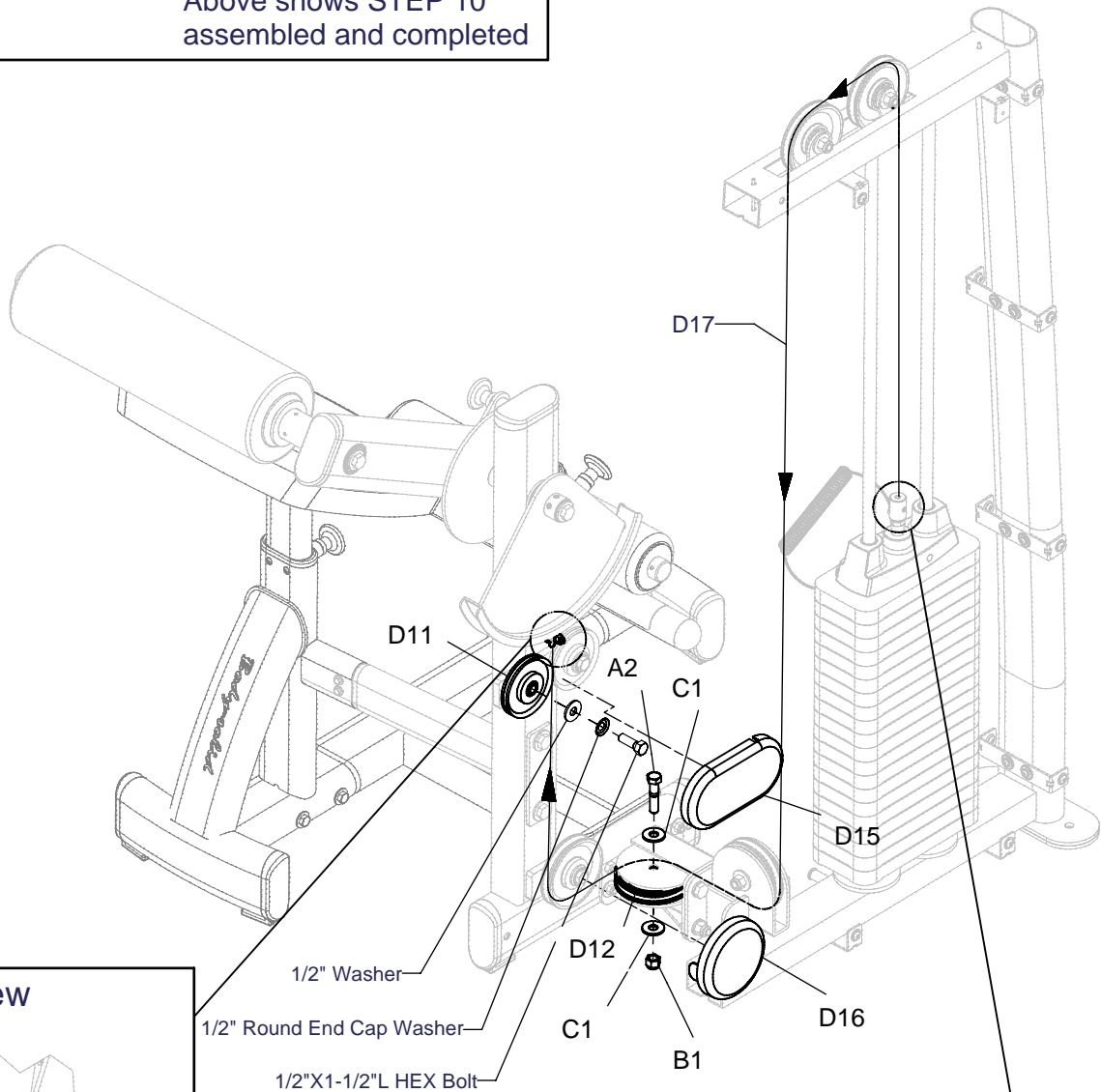

Detail View

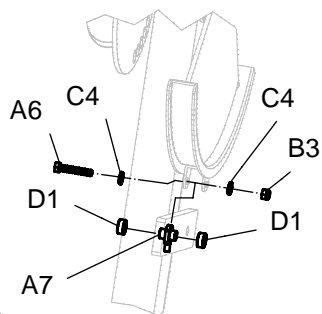

Detail View

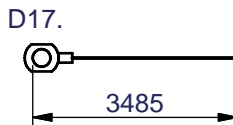
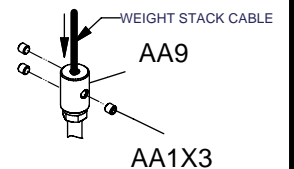

DABB ASSEMBLY INSTRUCTIONS

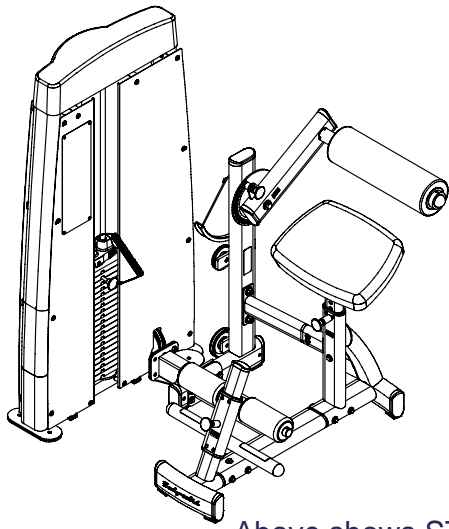

Above shows STEP 11
assembled and completed

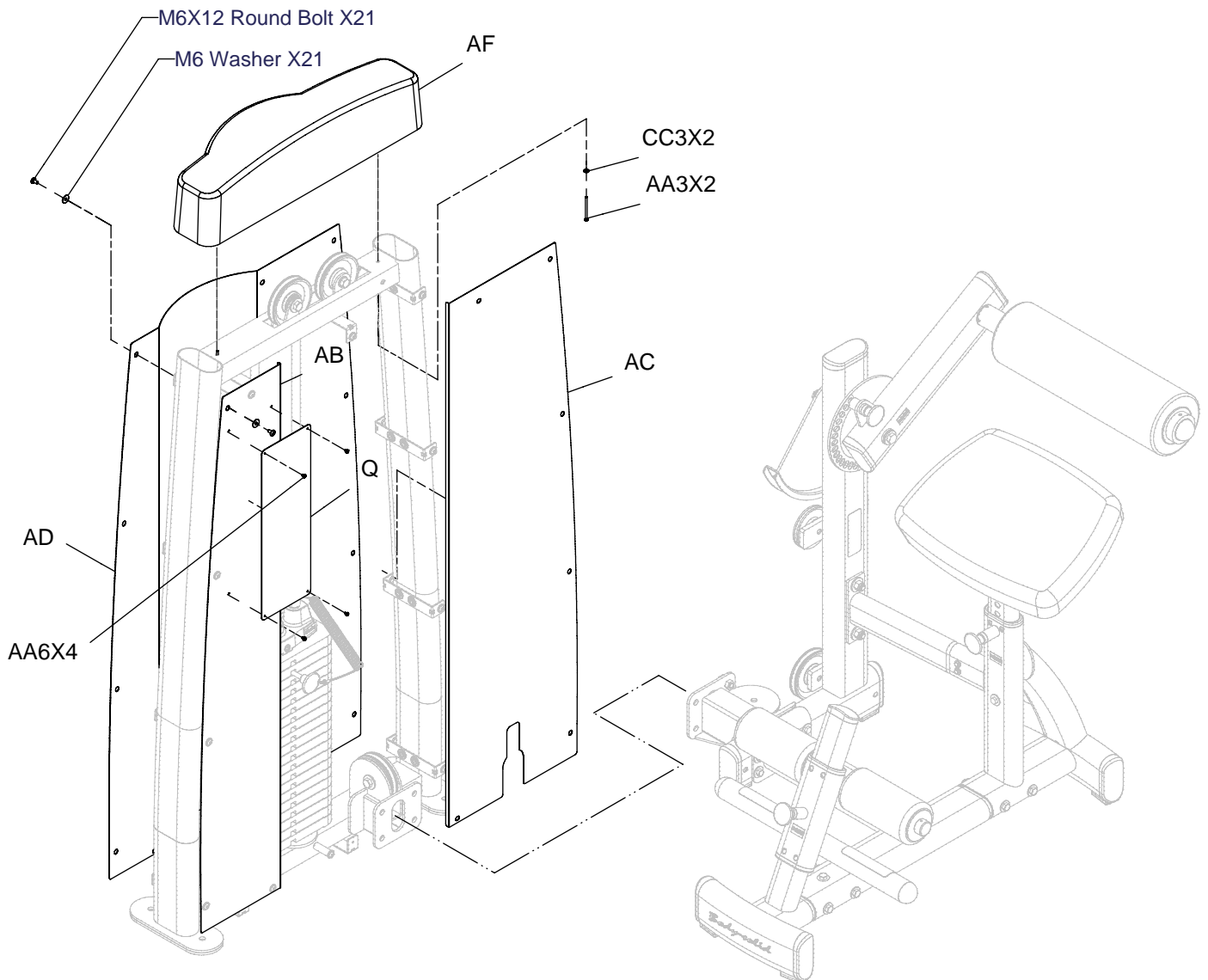

DABB ASSEMBLY INSTRUCTIONS

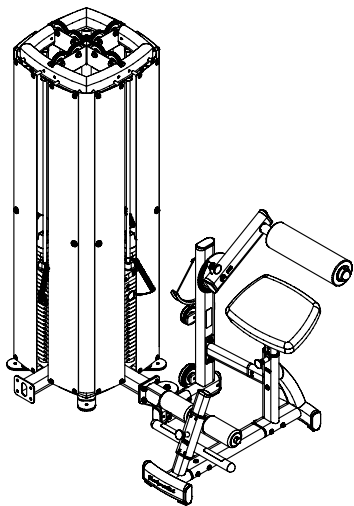

Above shows STEP 12 assembled and completed

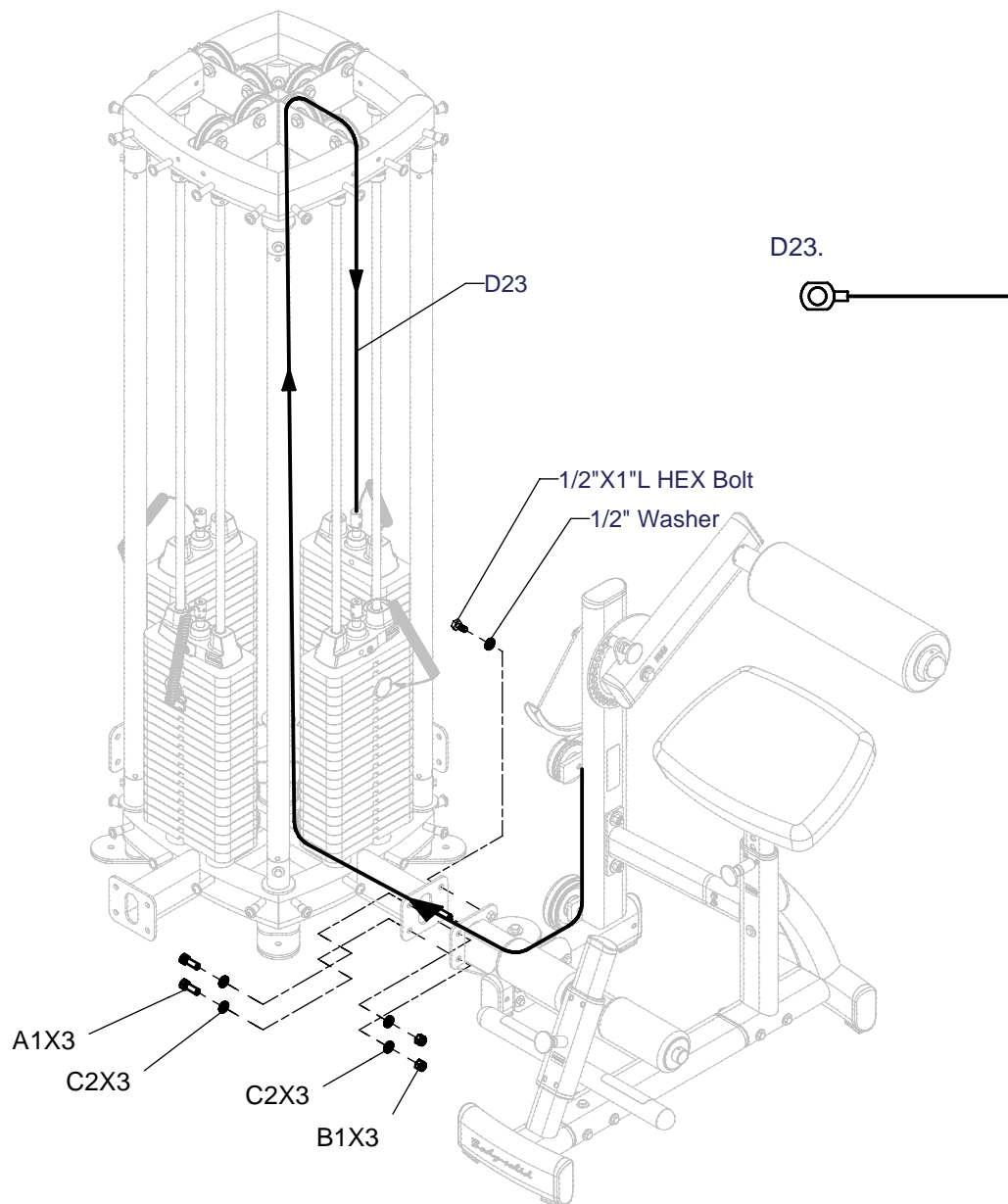

DABB ASSEMBLY INSTRUCTIONS

