

# Body-Solid

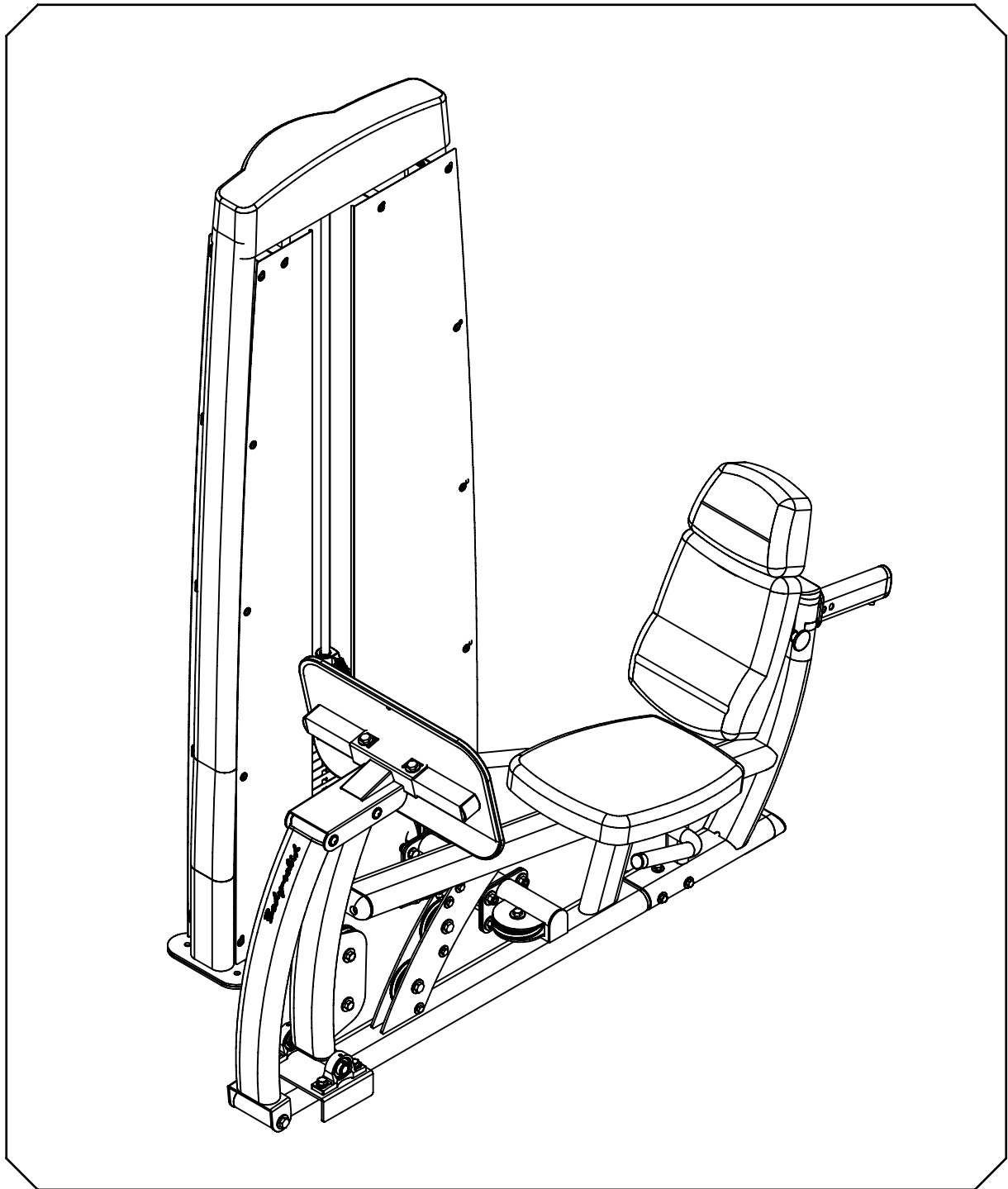

BODY-SOLID, Inc.  
1900 S. Des Plaines Ave.  
Forest Park, IL 60130 USA  
Phone: (708) 427-3555  
Fax: (708) 427-3556  
[www.bodysolid.com](http://www.bodysolid.com)

## DCLP OWNER'S MANUAL

# DCLP ASSEMBLY INSTRUCTIONS

## HARDWARW ILLUSTRATION

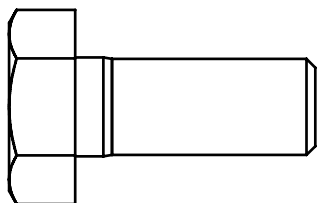

(A1)HEX BOLT 1/2"X1-1/4"L PARTIAL QTY.8

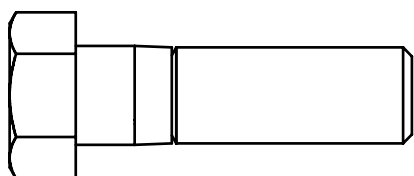

(A2)HEX BOLT 1/2"X1-3/4"L PARTIAL QTY.4

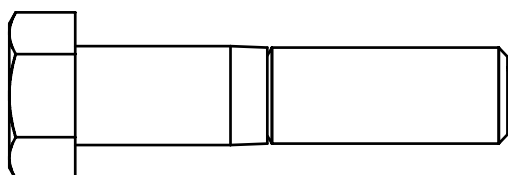

(A3)HEX BOLT 1/2"X2-1/4"L PARTIAL QTY.2

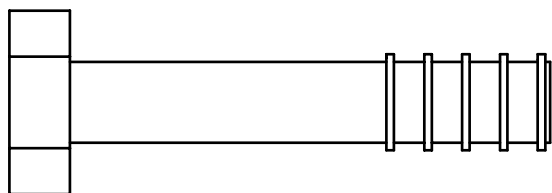

(A4)HEX BOLT 1/2"X2-1/2"L PARTIAL QTY.2

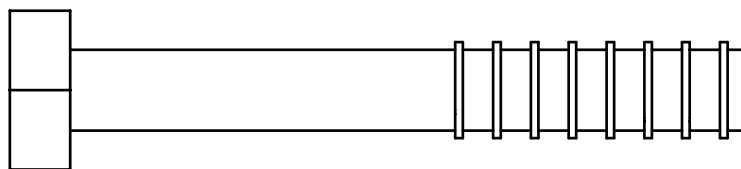

(A5)HEX BOLT 1/2"X3-1/2"L PARTIAL QTY.2

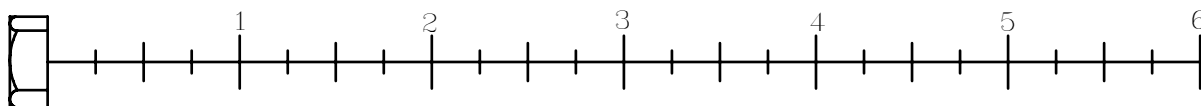

# DCLP ASSEMBLY INSTRUCTIONS

## HARDWARW ILLUSTRATION

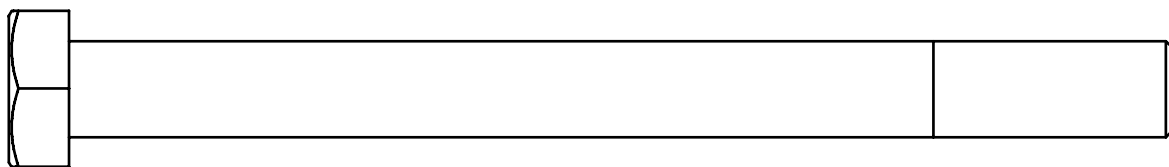

(A6)HEX BOLT 1/2"X5-3/4"L PARTIAL QTY.2

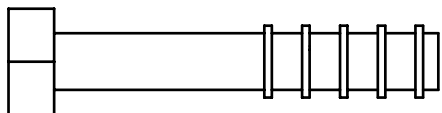

(A7)HEX BOLT 3/8"X2"L PARTIAL QTY.4

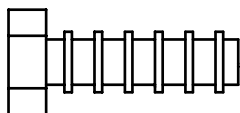

(A8)HEX BOLT 5/16"X1"L PARTIAL QTY.4

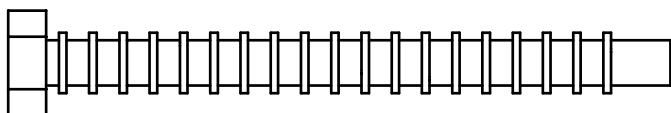

(A9)HEX BOLT 5/16X3-1/4"L PARTIAL QTY.2

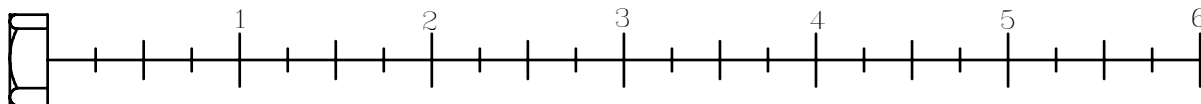

# DCLP ASSEMBLY INSTRUCTIONS

## HARDWARW ILLUSTRATION

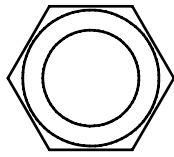
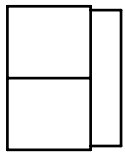

(B1) NYLON LOCK NUT 1/2" QTY.20

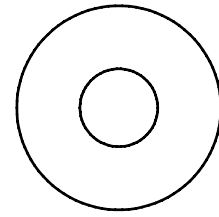

(C3) 3/8" (I.D.) FLAT WASHER Ø27 QTY.8

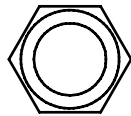
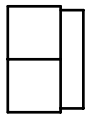

(B2) NYLON LOCK NUT 3/8" QTY.4

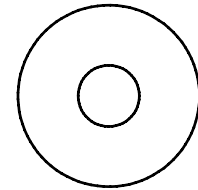

(C4) 5/16" (I.D.) FLAT WASHER Ø24 QTY.6

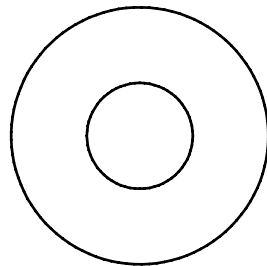

(C1) 1/2" (I.D.) FLAT WASHER Ø34 QTY.24

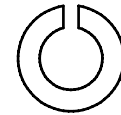

(C5) SPRING WASHER 5/16" QTY.6

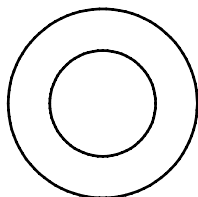

(C2) 1/2" (I.D.) FLAT WASHER Ø25 QTY.16

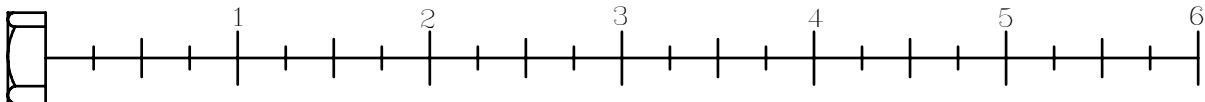

# DCLP ASSEMBLY INSTRUCTIONS

## HARDWARW ILLUSTRATION



(AA1) ALLEN SCREW 5/16"X3/8"L FULL THREAD QTY.3

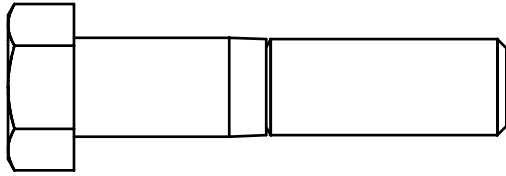

(AA2) HEX BOLT 1/2"X2-1/4"L PARTIAL QTY.4

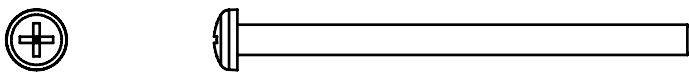

(AA3) ROUND INNER HEX SCREW M4X65L PARTIAL QTY.2

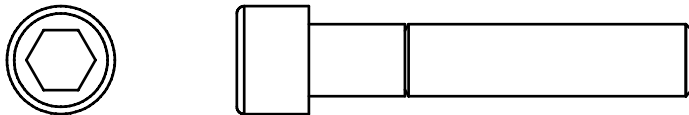

(AA4) ROUND INNER HEAD 3/8"X2"L PARTIAL QTY.1

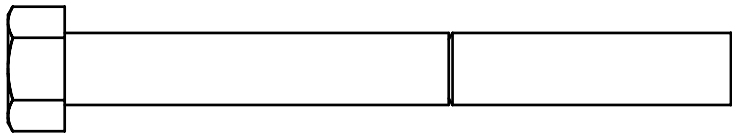

(AA5) ROUND INNER HEAD 3/8"X3-1/2"L PARTIAL QTY.1



(AA6) ROUND INNER HEX SCREW M6X20L PARTIAL QTY.24



(AA7) ROUND CROSS SCREW 5/32"X1/4"L PARTIAL QTY.4

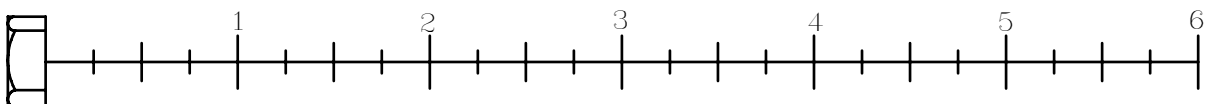

# DCLP ASSEMBLY INSTRUCTIONS

## HARDWARW ILLUSTRATION

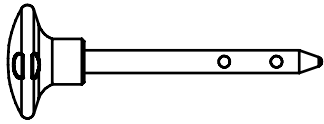

(AA8)10LB PIN(8250-071) QTY.1

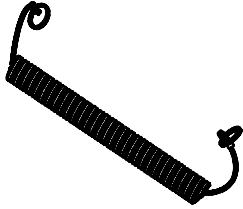

(AA9)ELASTIC BOLT QTY.1

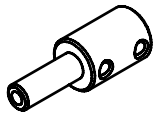

(AA10)CABLE FIXED BOLT(8260-009) QTY.1

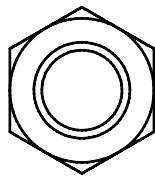

(BB1)NUT 1/2"-13UNC QTY.1

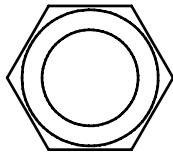
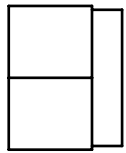

(BB2)NYLON LOCK NUT1/2" QTY.4

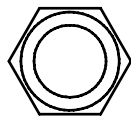
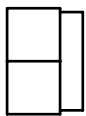

(BB3)NYLON LOCK NUT3/8" QTY.1

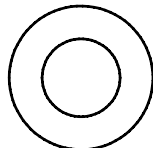

(CC1)3/8"(I.D.)FLAT WASHER Ø19 QTY.2

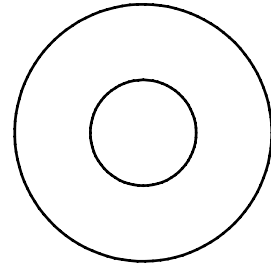
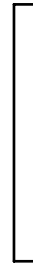

(CC2)1/2"(I.D.)FLAT WASHER Ø34 QTY.6

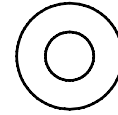
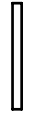

(CC3)M6(I.D.)FLAT WASHER Ø13 QTY.24

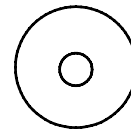

(CC4)M4(I.D.)FLAT WASHER Ø12 QTY.2

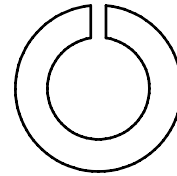
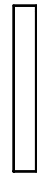

(CC5)SPRING WASHER 1/2" QTY.1

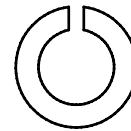

(CC6)SPRING WASHER 3/8" QTY.1

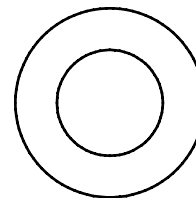

(CC7)1/2"(I.D.)FLAT WASHER Ø25 QTY.2



# DCLP ASSEMBLY INSTRUCTIONS

## HARDWARW ILLUSTRATION

D1

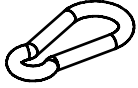

D2



D3

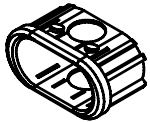

D4

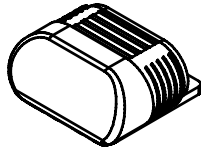

D5

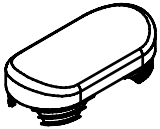

D6



D7

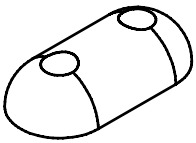

D8

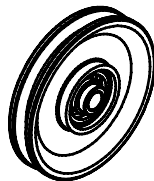

D9



D10

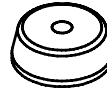

D11

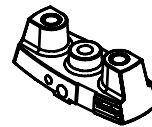

D12

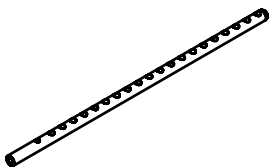

D13



D14

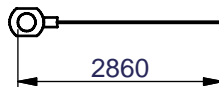

D15

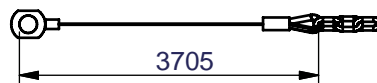

(D1)∅8 SPRING SNAP LINK(8810-001) -----	[1PCS]
(D2)□50X50X1.8t END CAP(9211-087) -----	[2PCS]
(D3)50X100 NYLON BUSHING(9211-107) -----	[2PCS]
(D4)58X116X2.5tX65H FOOT CAP(9211-109) -----	[1PCS]
(D5)58X116X2.5t END CAP(9211-112)-----	[1PCS]
(D6)40X80X2t END CAP(9211-113) -----	[1PCS]
(D7)116X58X29 RUBBER PAD(9310-057)-----	[1PCS]
(D8)∅4" 1/2"PULLEY(9213-010B) -----	[9PCS]
(D9)∅3/4" SHAFT COLLAR(9211-046) -----	[2PCS]
(D10)∅4"RUBBER DOUNT(9310-017)-----	[2PCS]
(D11)TOP PLATE(8400-006) -----	[1PCS]
(D12)WEIGHT SELECTOR BAR(8210-042) -----	[1PCS]
(D13)95X250 RUBBER PAD(9310-060) -----	[2PCS]
(D14)2860 STEEL CABLE(FDCLPA) -----	[1PCS]
(D15)3705 STEEL CABLE(FDCLPB) -----	[1PCS]
(D16)DLP FOR DGYM STEEL CABLE(FDCLPC) -----	[1PCS]

# DCLP ASSEMBLY INSTRUCTIONS

## PARTS ILLUSTRATION

A [1PCS]

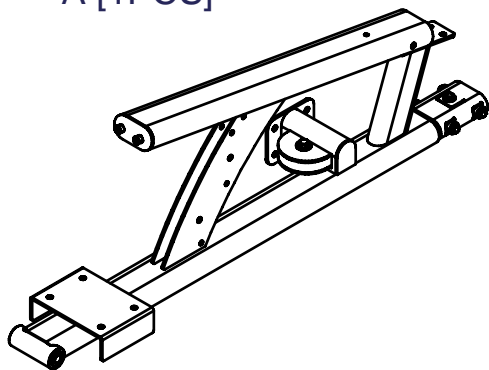

B [1PCS]

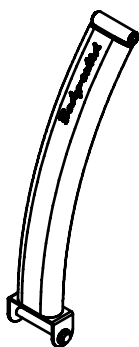

C [1PCS]

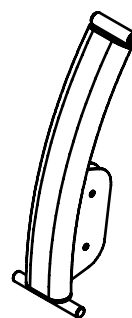

D [1PCS]

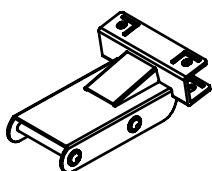

E [1PCS]

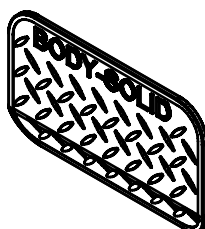

F [1PCS]

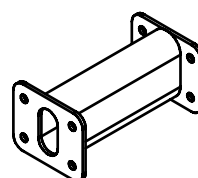

G [1PCS]

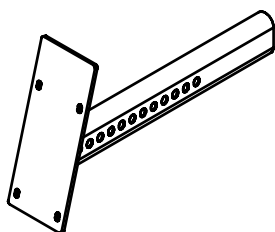

H [1PCS]

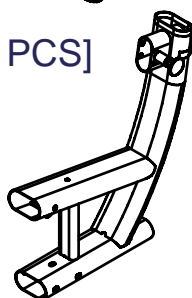

I [1PCS]

Direction



J [1PCS]

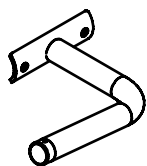

Direction



K [1PCS]  
9111-055

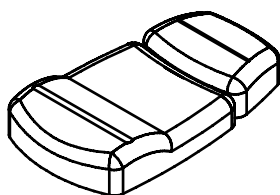

L [1PCS]  
9122-040

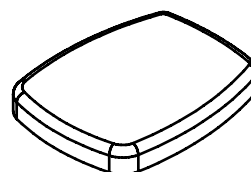

M [2PCS]  
8510-005

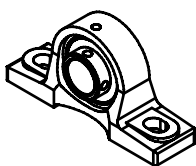

N [1PCS]  
6640-001

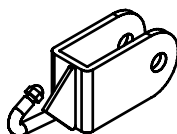

O [1PCS]  
9440-160

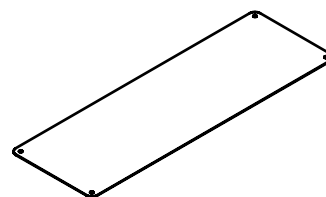



# DCLP ASSEMBLY INSTRUCTIONS

## PARTS ILLUSTRATION

AA[1PCS]  
6610-003

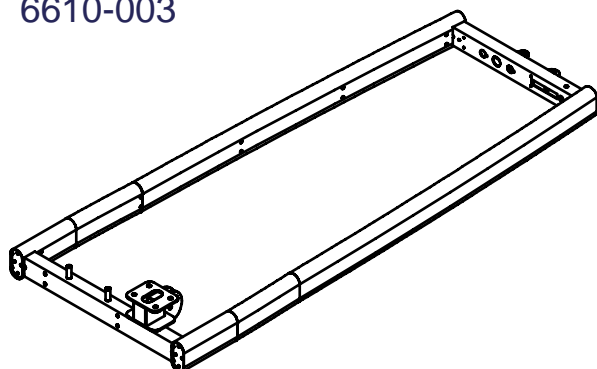

AB[1PCS]  
8380-051

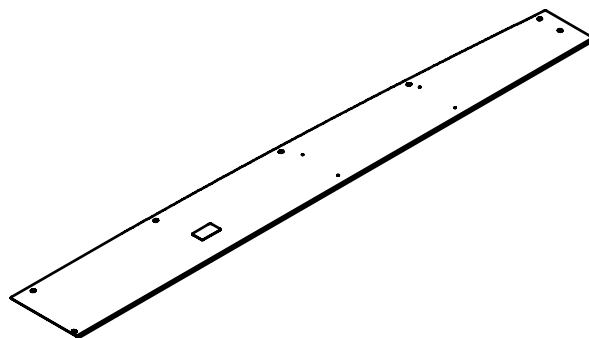

AC[1PCS]  
8380-049

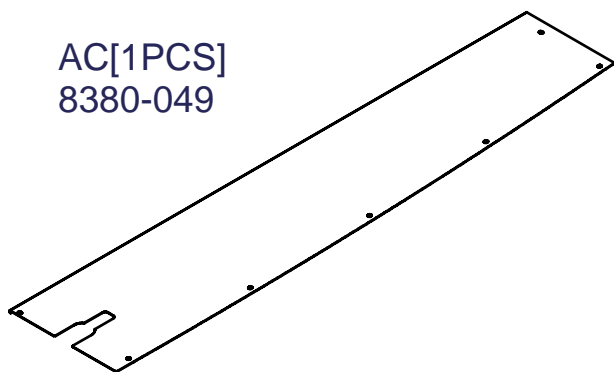

AD[1PCS]  
8380-050

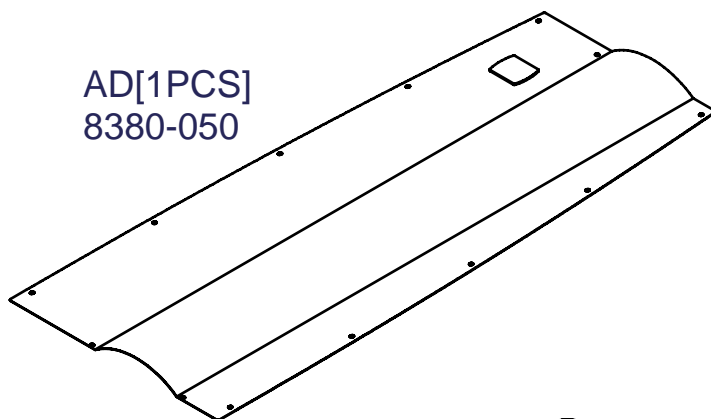

AE[2PCS]  
260159 (Ø3/4"X1932L)



AF[1PCS]  
9211-111

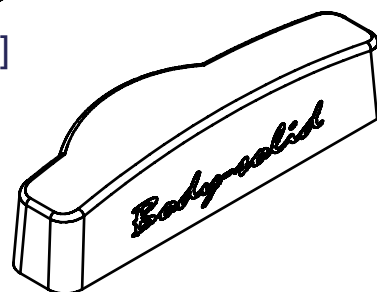

AG[2PCS]  
8313-144

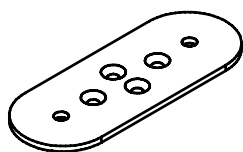

AH[11PCS]  
8321-040

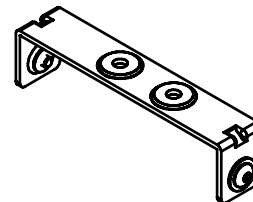
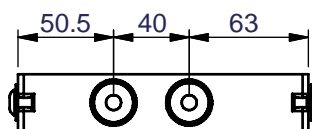

AI[1PCS]  
8321-040

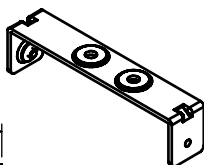
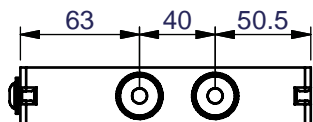

AJ[2PCS]  
8321-040

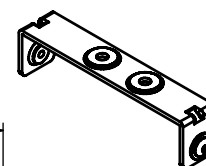
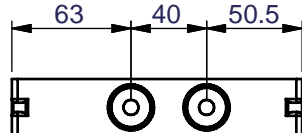

# DCLP ASSEMBLY INSTRUCTIONS

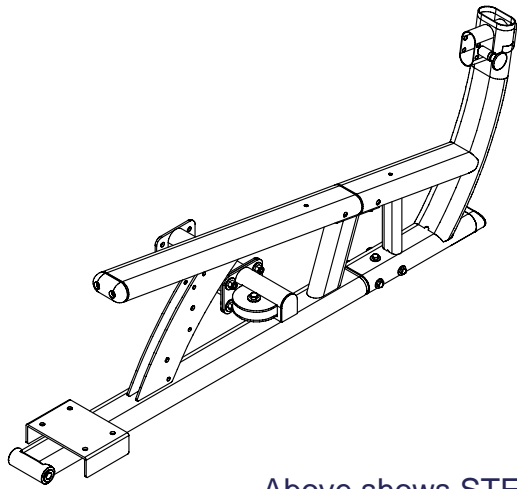

Above shows STEP 1  
assembled and completed

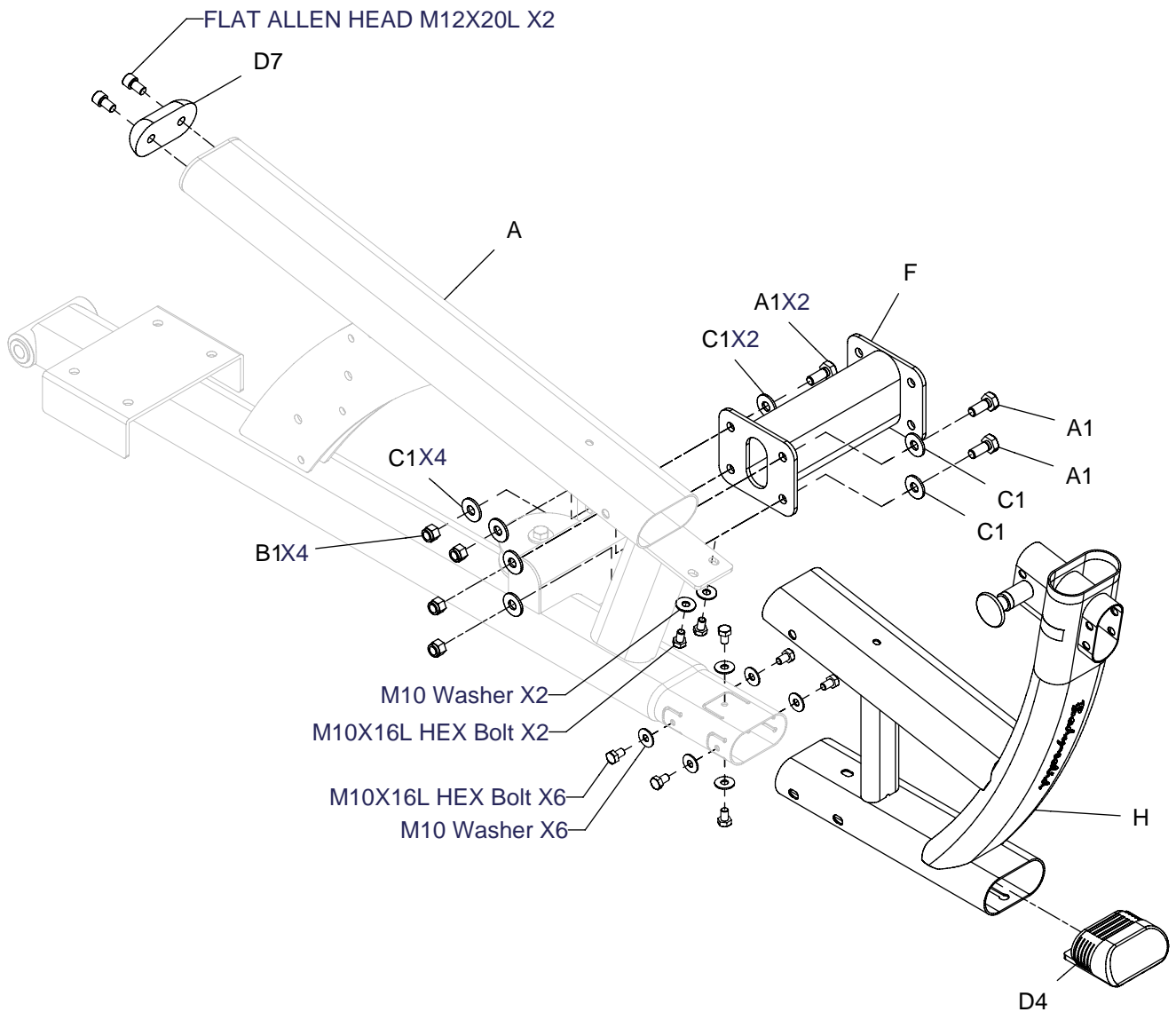

# DCLP ASSEMBLY INSTRUCTIONS

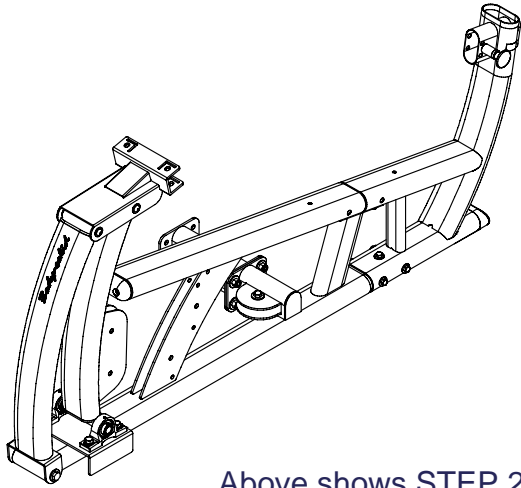

Above shows STEP 2  
assembled and completed

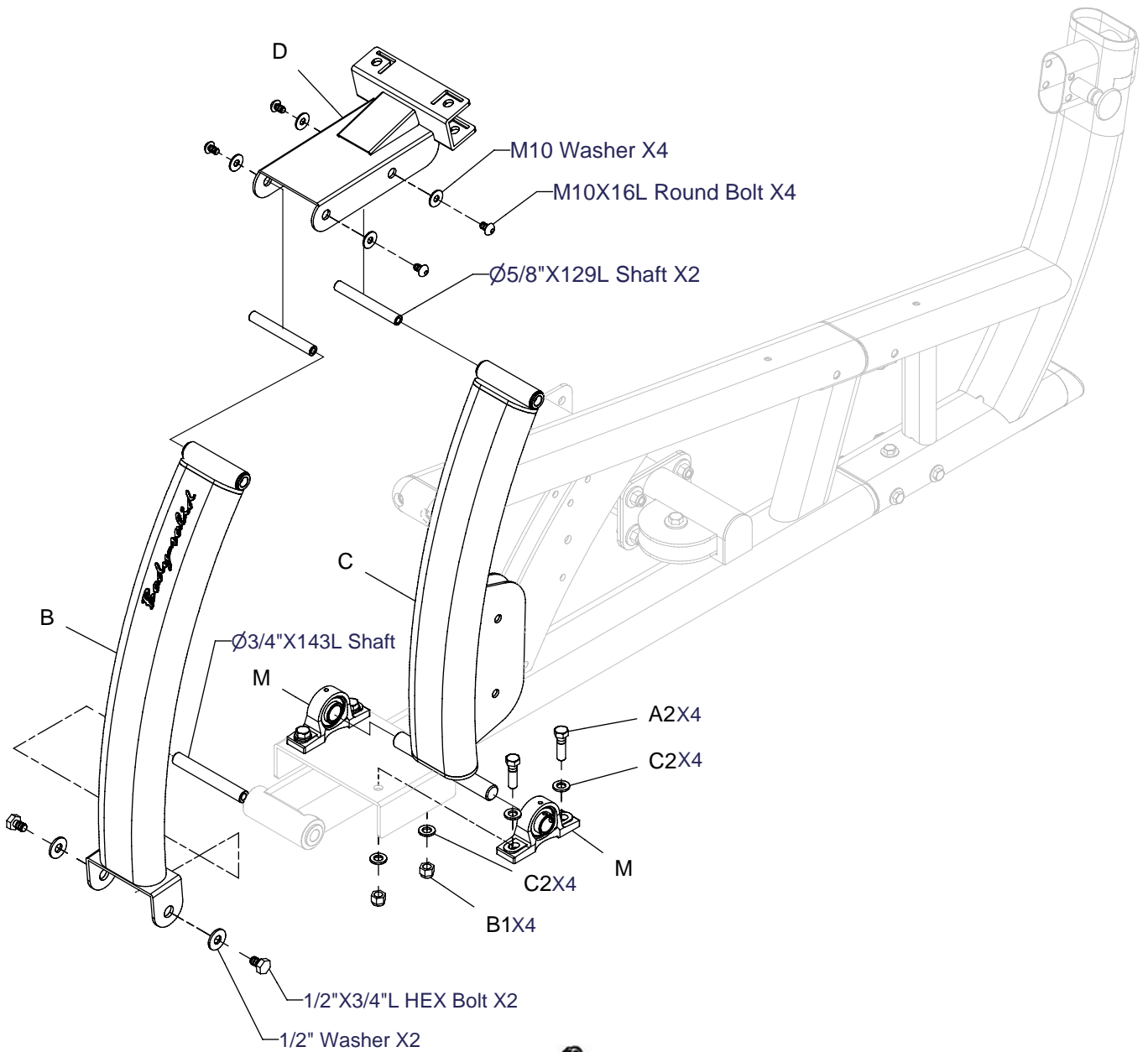

# DCLP ASSEMBLY INSTRUCTIONS

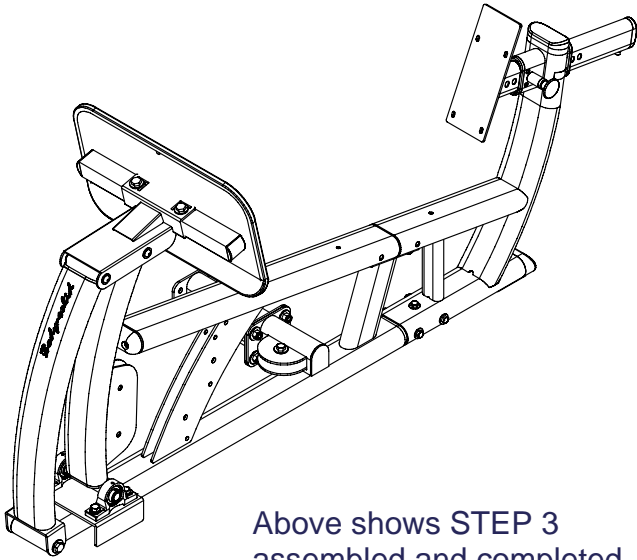

Above shows STEP 3  
assembled and completed

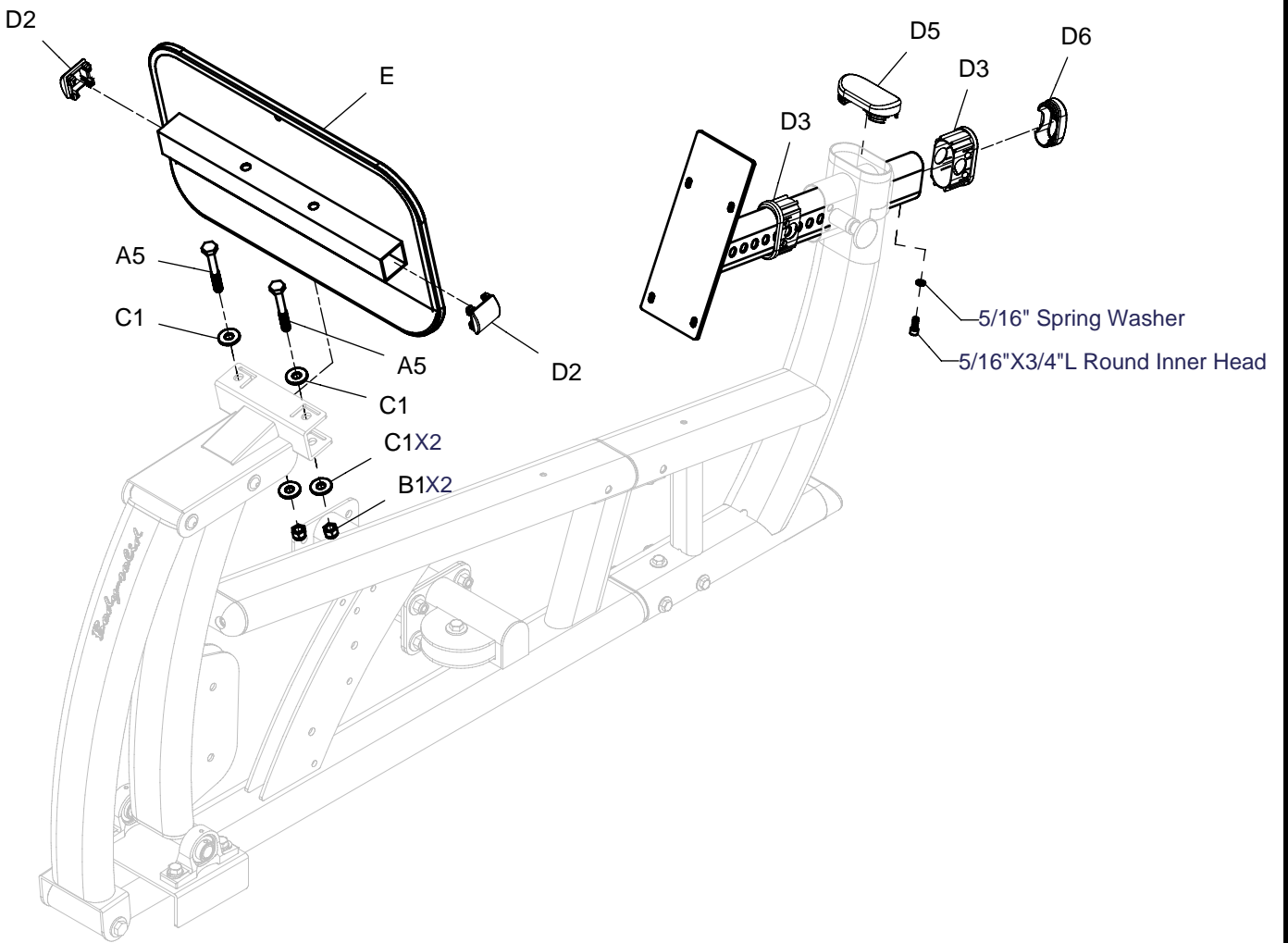

# DCLP ASSEMBLY INSTRUCTIONS

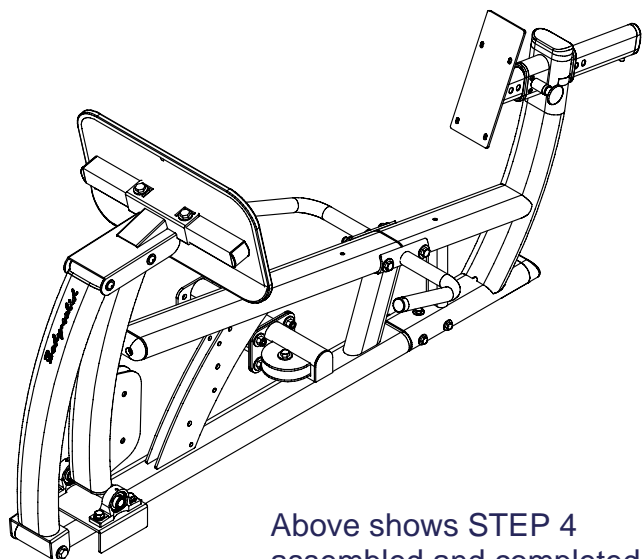

Above shows STEP 4  
assembled and completed

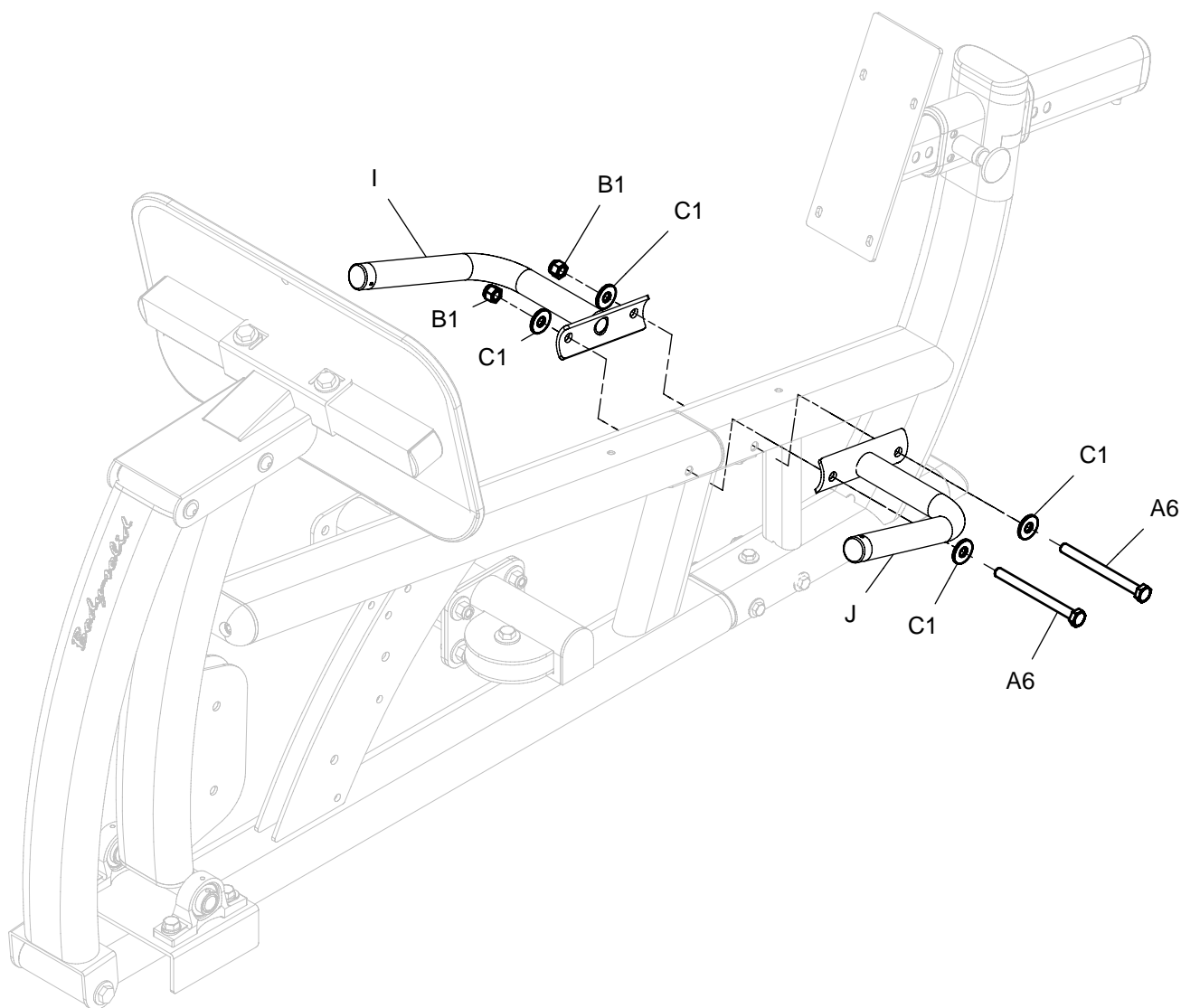

# DCLP ASSEMBLY INSTRUCTIONS

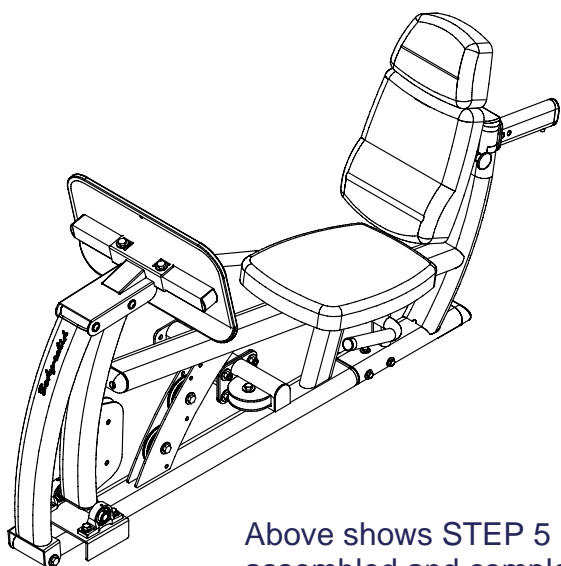

Above shows STEP 5  
assembled and completed

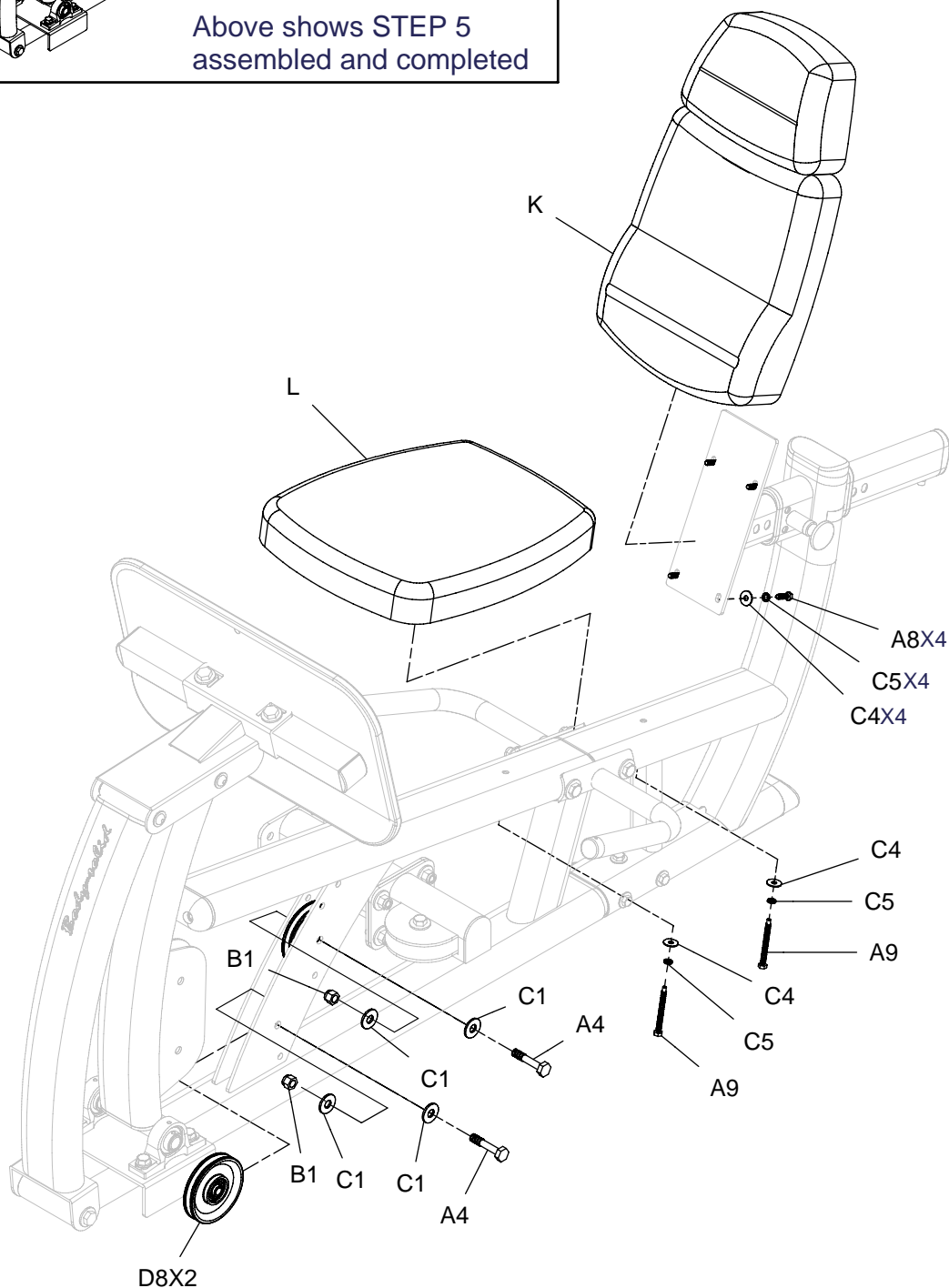

# DCLP ASSEMBLY INSTRUCTIONS

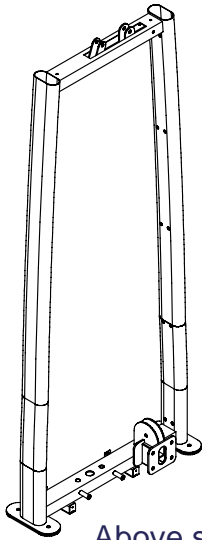

Above shows STEP 6  
assembled and completed

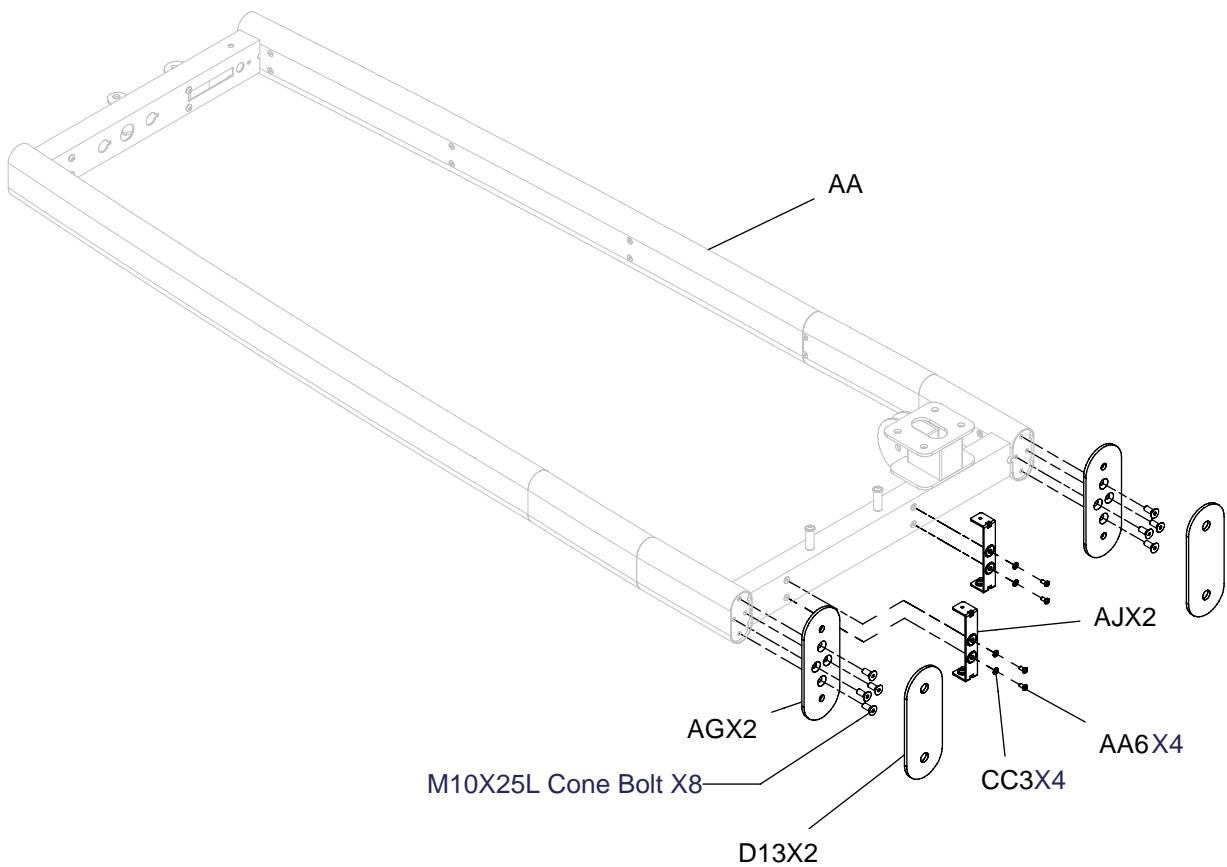

# DCLP ASSEMBLY INSTRUCTIONS

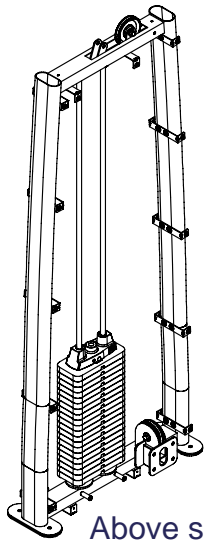

Above shows STEP 7  
assembled and completed

NOTE : FINGER TIGHTEN  
PULLEY FASTENERS  
PULLEYS WILL BE  
REMOVED TO INSTALL CABLE

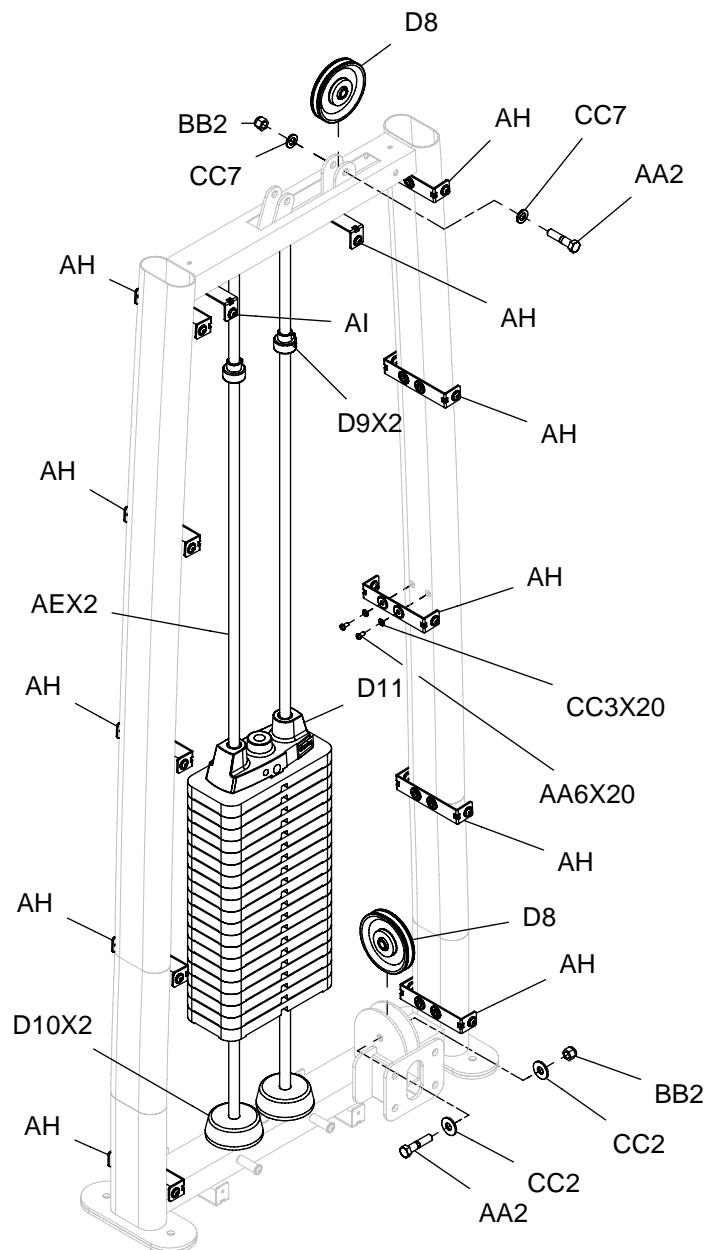



# DCLP ASSEMBLY INSTRUCTIONS

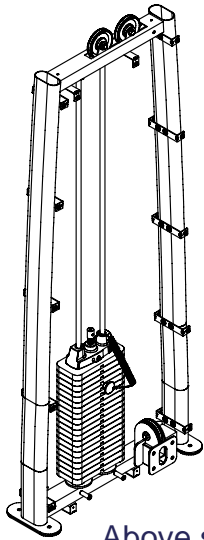

Above shows STEP 8  
assembled and completed

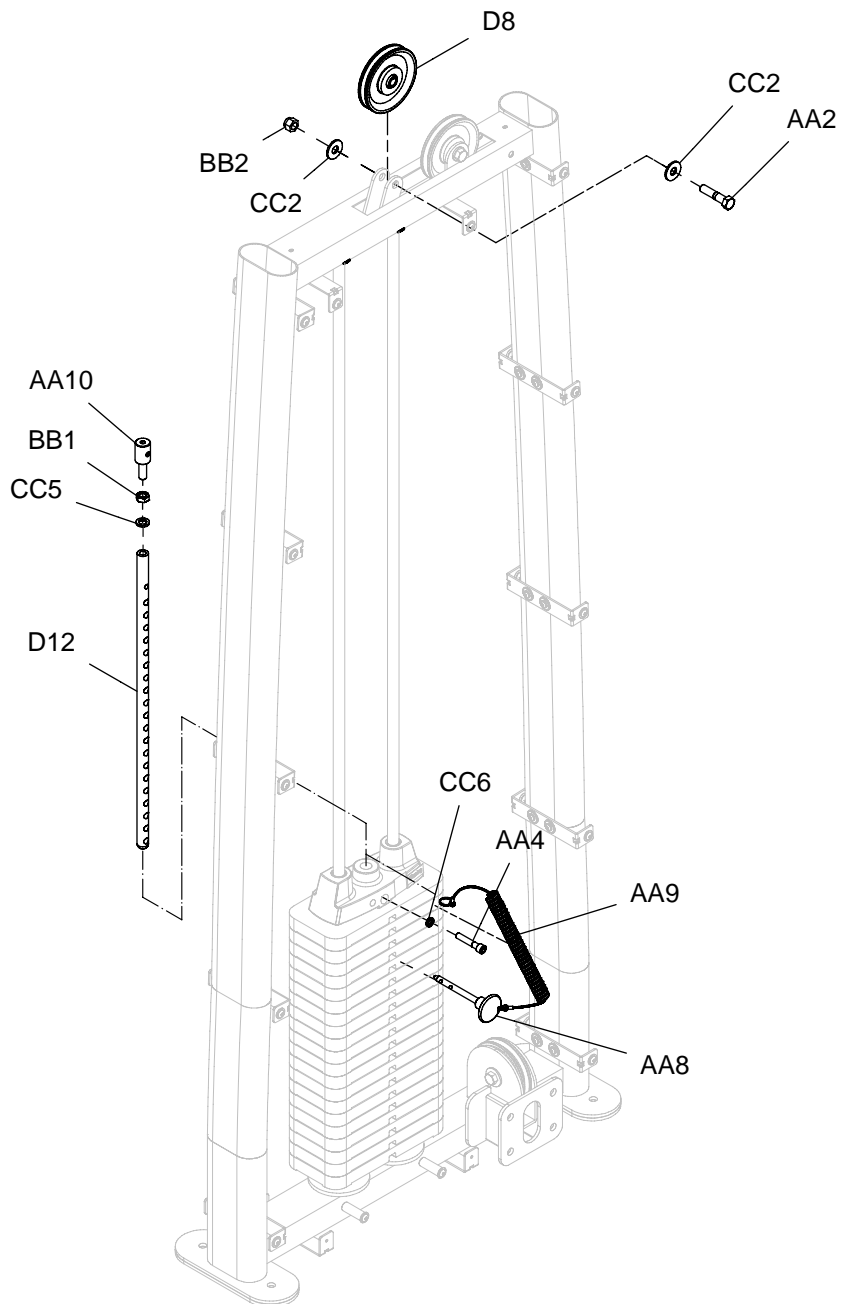

# DCLP ASSEMBLY INSTRUCTIONS

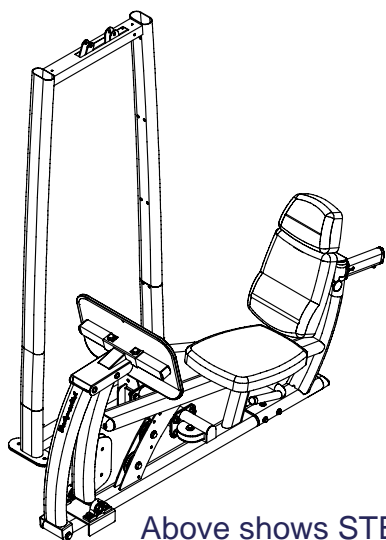

Above shows STEP 9  
assembled and completed

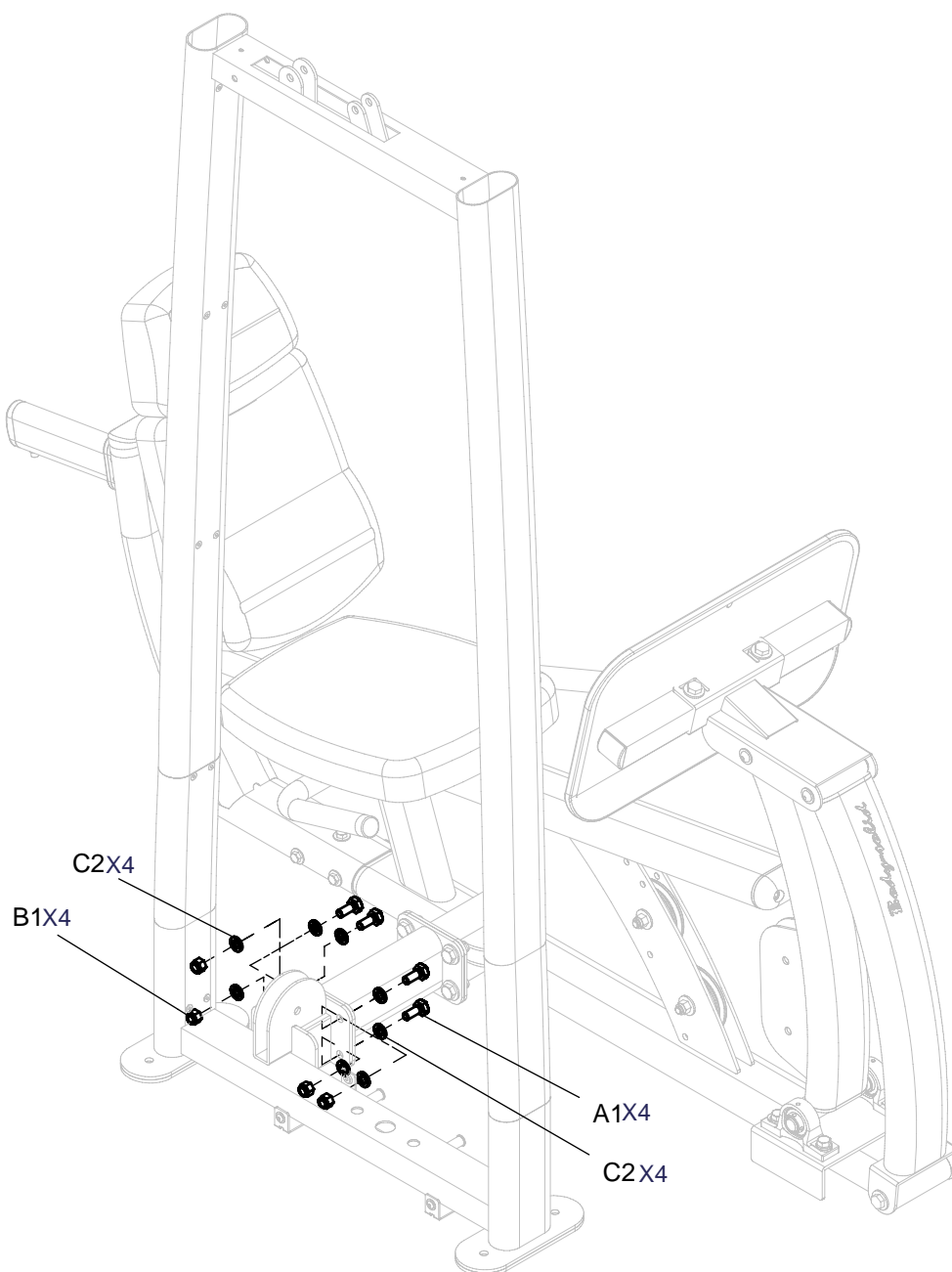

# DCLP ASSEMBLY INSTRUCTIONS

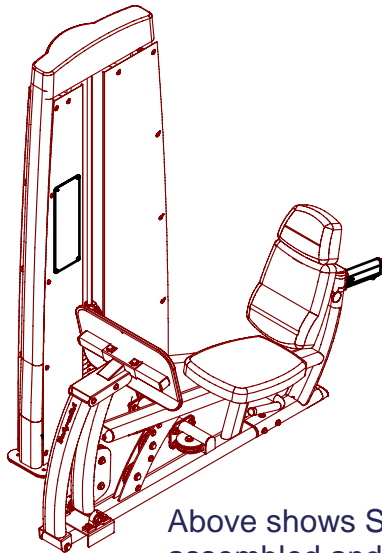

Above shows STEP 10 assembled and completed

D14.

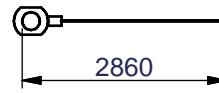

D15.

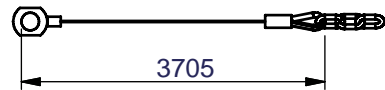

## Detail View

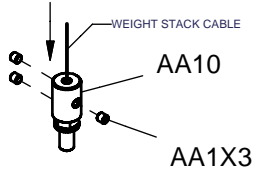

## Detail View

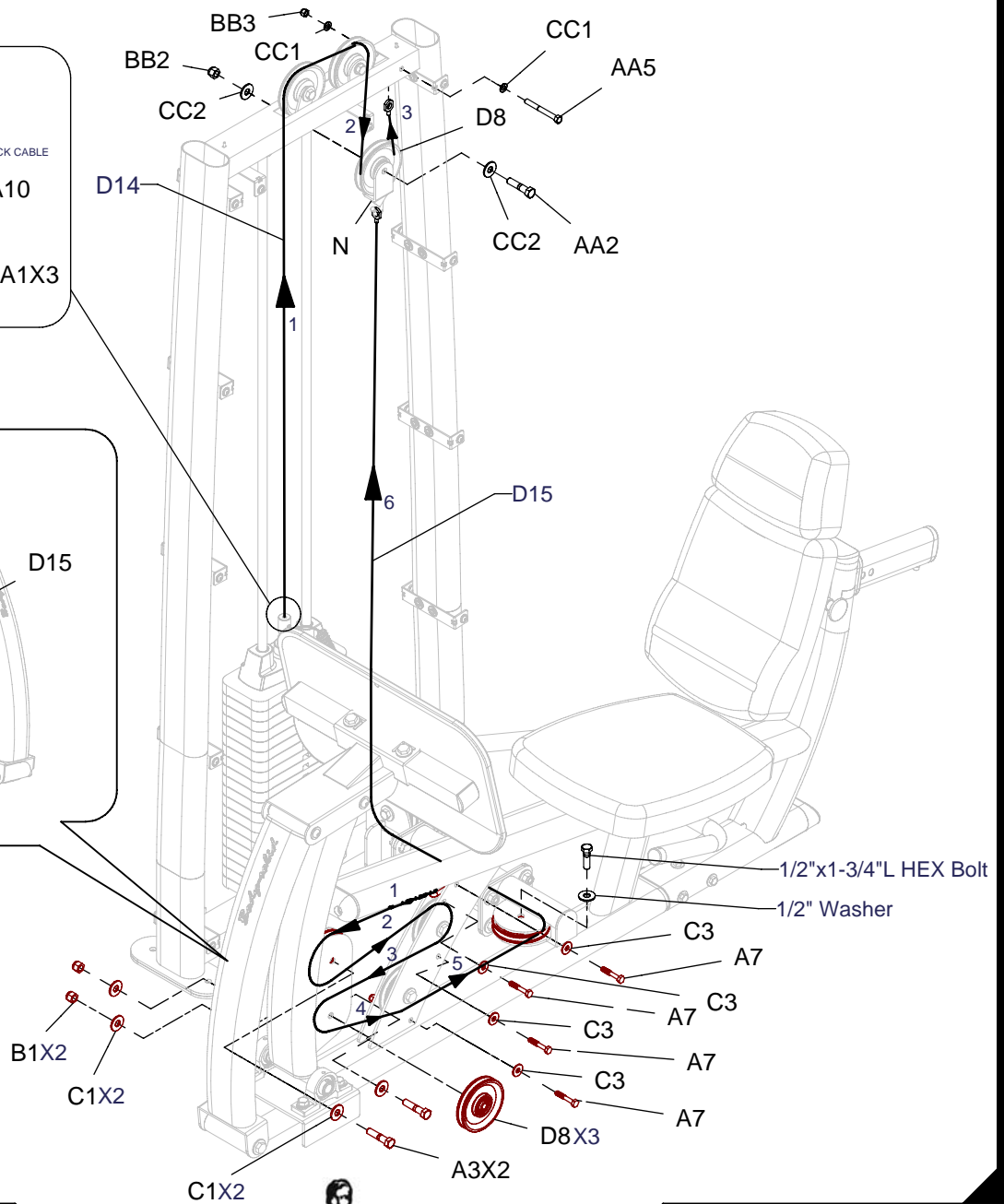
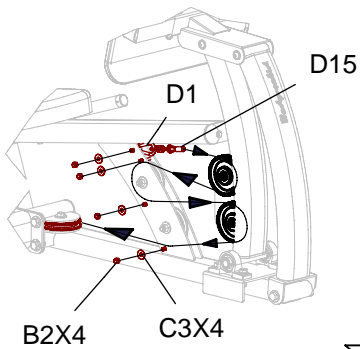

# DCLP ASSEMBLY INSTRUCTIONS

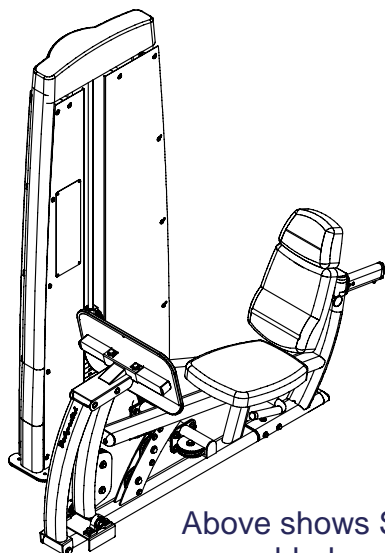

Above shows STEP 11  
assembled and completed

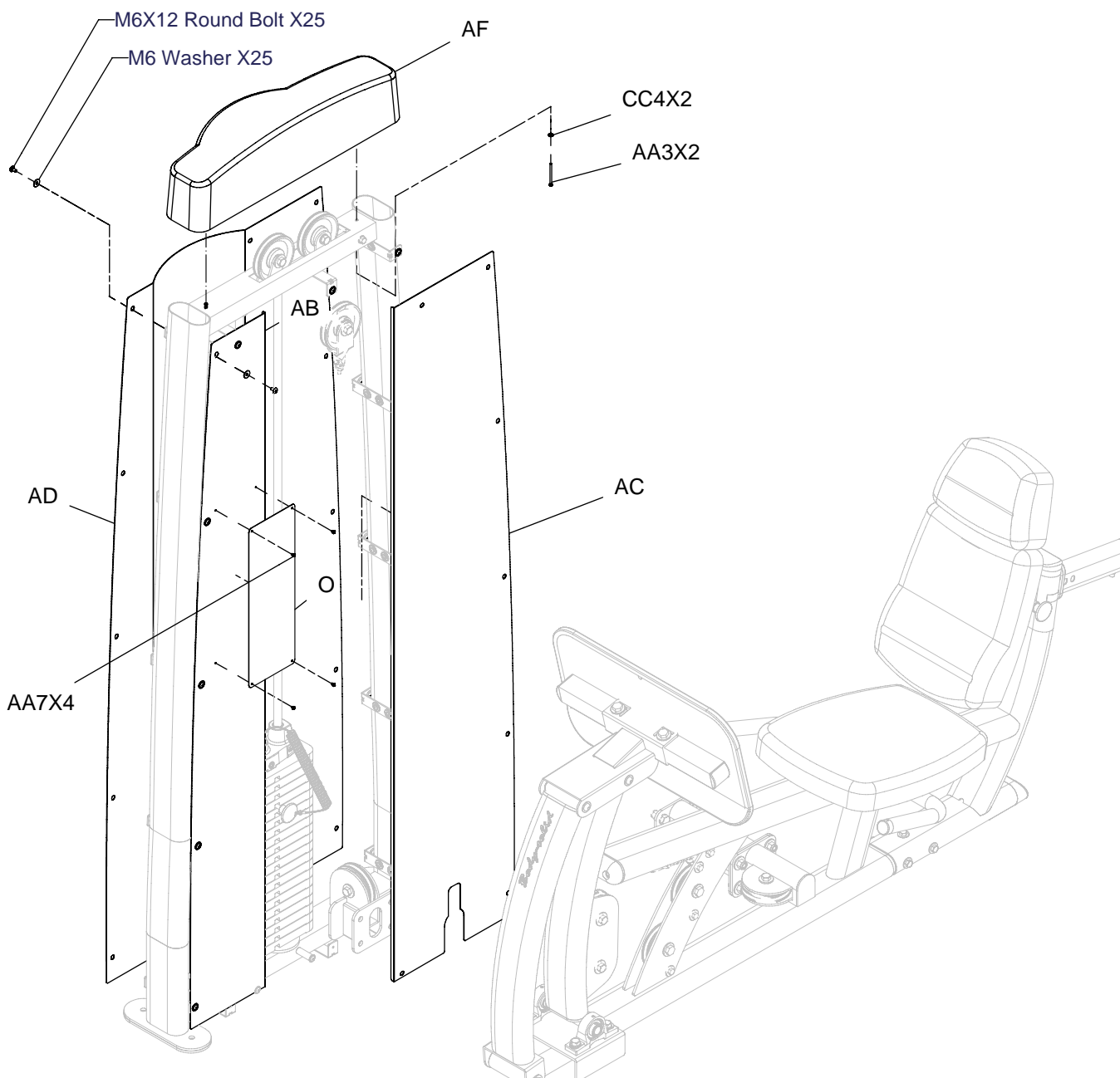

# DCLP ASSEMBLY INSTRUCTIONS

Cable to match illustration

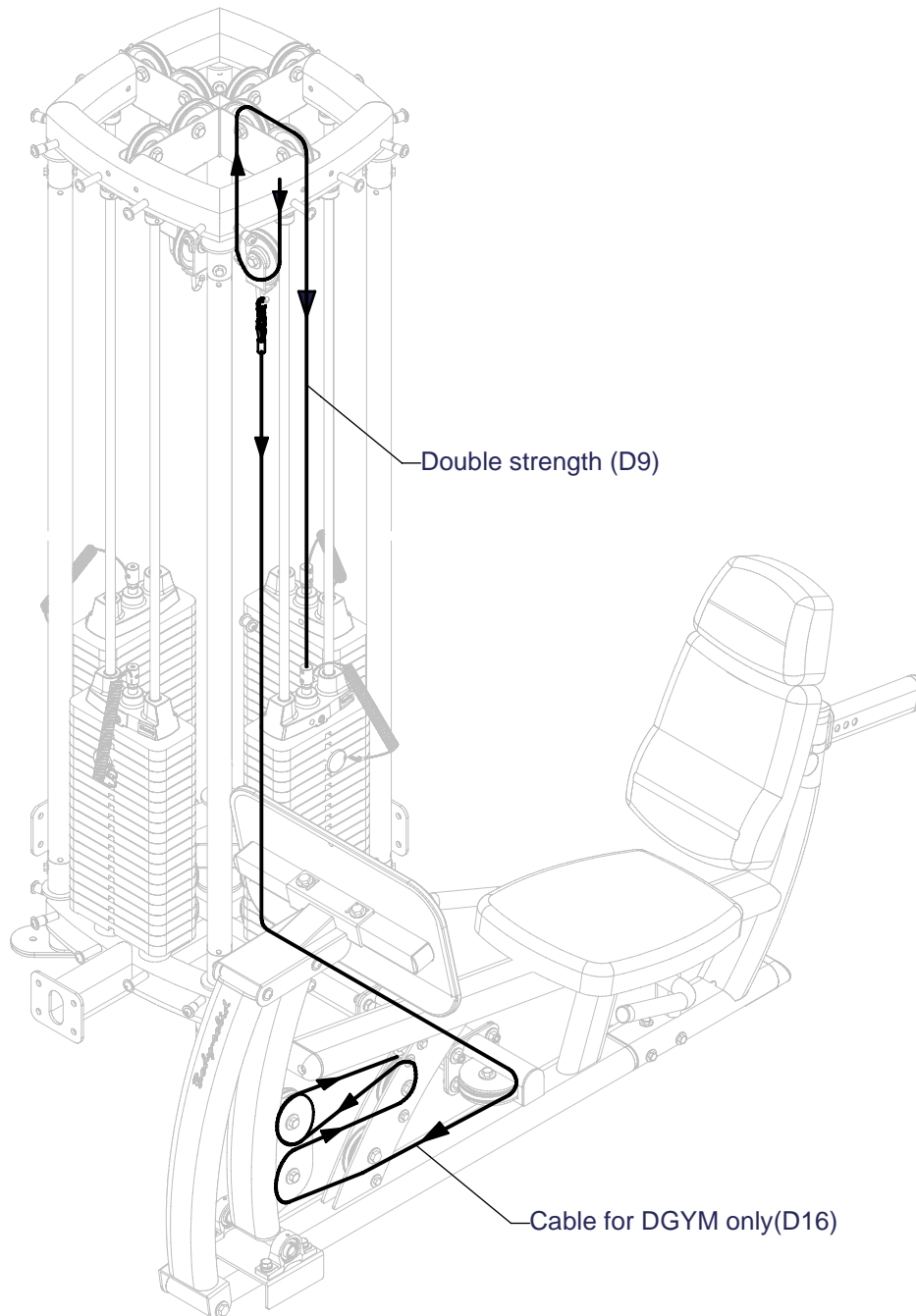

# DCLP ASSEMBLY INSTRUCTIONS

