

Body-Solid

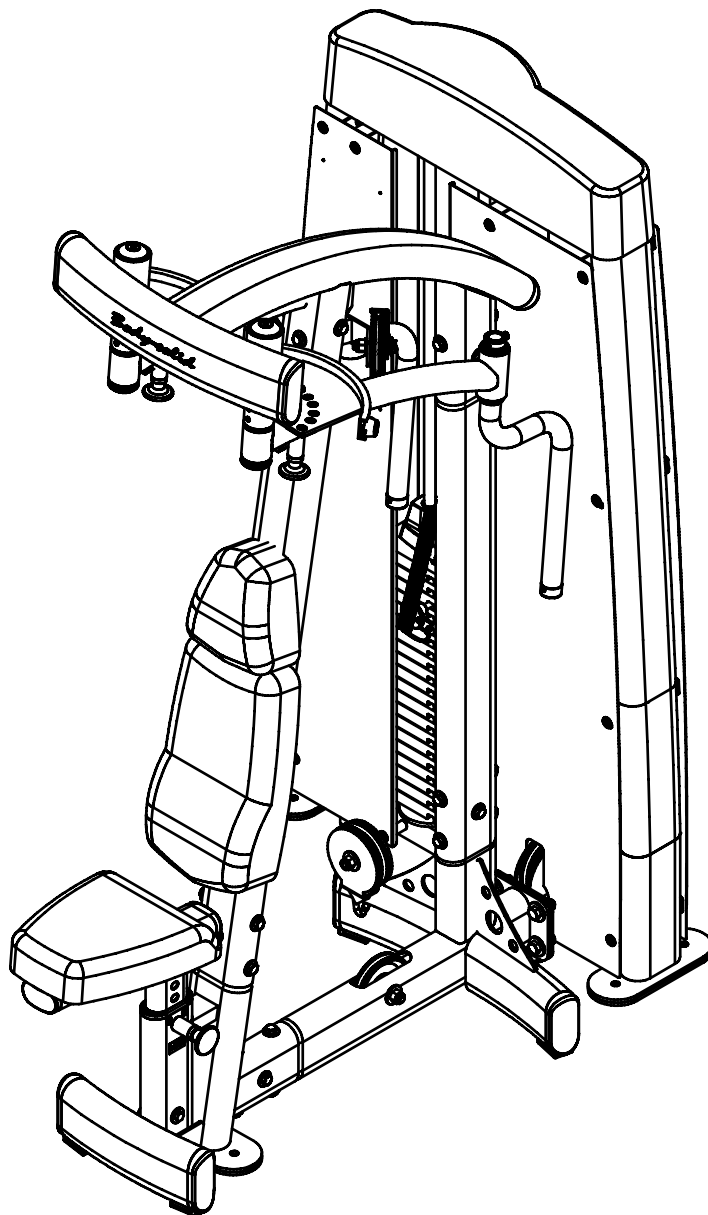

BODY-SOLID, Inc.
1900 S. Des Plaines Ave.
Forest Park, IL 60130 USA
Phone: (708) 427-3555
Fax: (708) 427-3556
www.bodysolid.com

DPEC OWNER'S MANUAL

DPEC ASSEMBLY INSTRUCTIONS

HARDWARE ILLUSTRATION

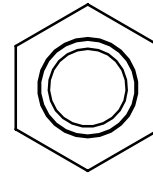
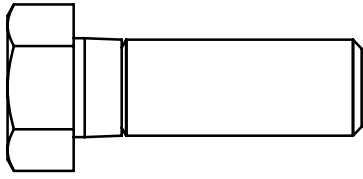

(A1)HEX BOLT 1/2"x1 1/2"L PARTIAL THREAD QTY.4

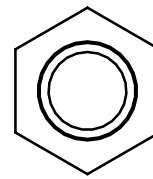
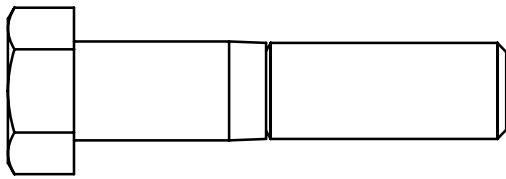

(A2)HEX BOLT 1/2"x2 1/4"L PARTIAL THREAD QTY.1

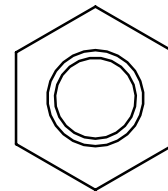
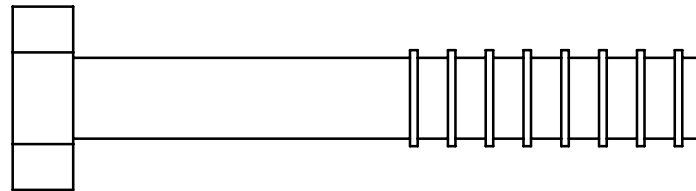

(A3)HEX BOLT 1/2"x3 1/4"L PARTIAL THREAD QTY.1

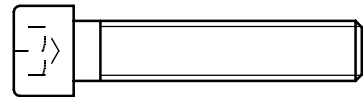

(A4)ROUND ALLEN HEAD 5/16"x1 1/2"L PARTIAL THREAD QTY.2

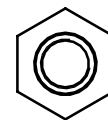
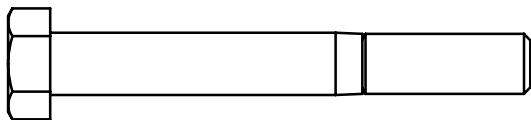

(A5)HEX BOLT 5/16"x2 1/2"L PARTIAL THREAD QTY.2

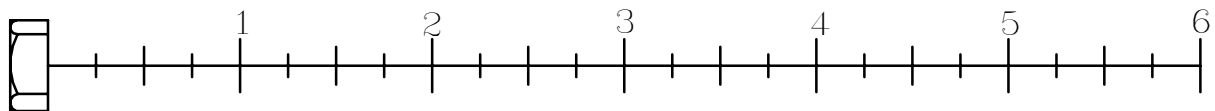

DPEC ASSEMBLY INSTRUCTIONS

HARDWARE ILLUSTRATION

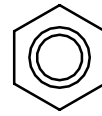
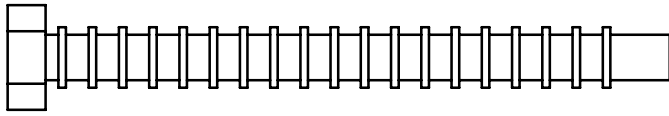

(A6)HEX BOLT 5/16"x3 1/4"L PARTIAL THREAD QTY.4

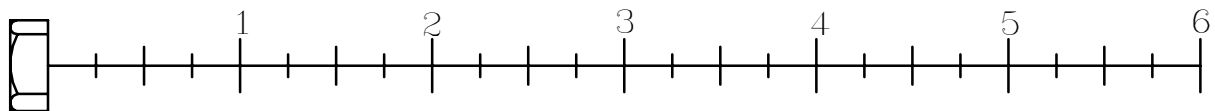

DPEC ASSEMBLY INSTRUCTIONS

FRAME HARDWARE ILLUSTRATION



(A7) ALLEN SCREW 5/16" X 3/8" L FULL THREAD QTY. 3

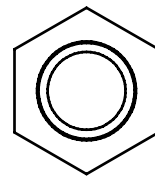
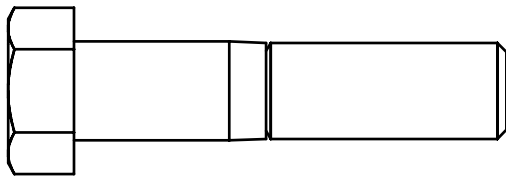

(A8) HEX BOLT 1/2" X 2 1/4" L PARTIAL THREAD QTY. 3

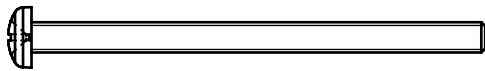

(A9) HEX BOLT M4 X 65 L PARTIAL THREAD QTY. 2

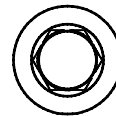
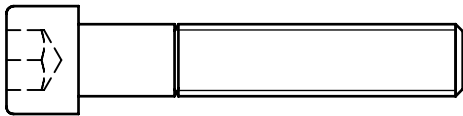

(A10) ROUND ALLEN HEAD 3/8" X 2" L PARTIAL THREAD QTY. 1

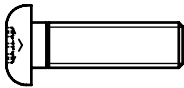

(A11) ROUND ALLEN HEAD M6 X 20 L PARTIAL THREAD QTY. 20

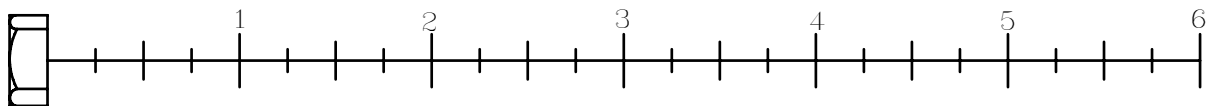

DPEC ASSEMBLY INSTRUCTIONS

FRAME HARDWARE ILLUSTRATION

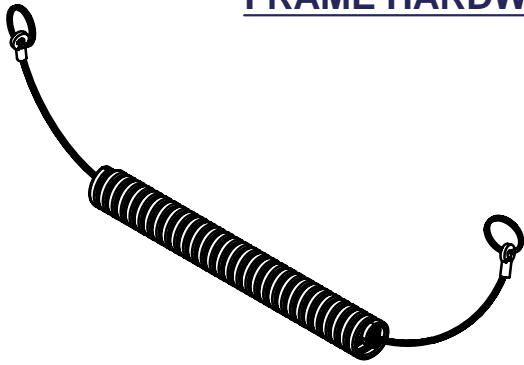

(A12)ELASTIC BOLT QTY.1

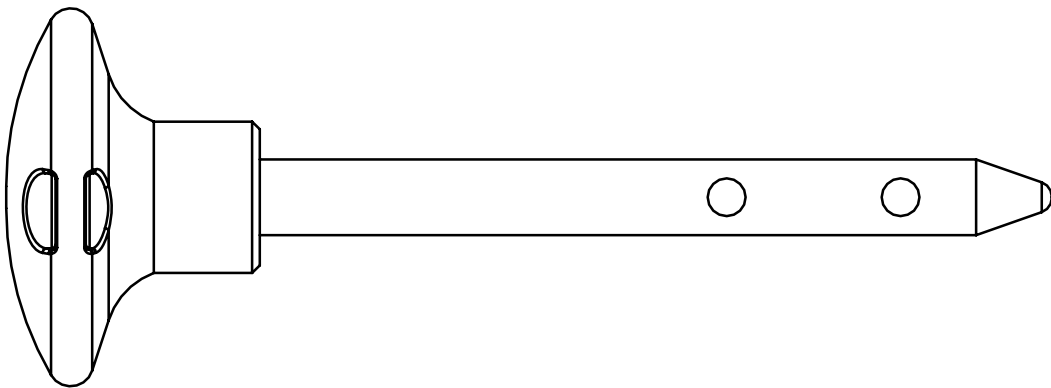

(A13)10LB PIN (8250-071) QTY.1

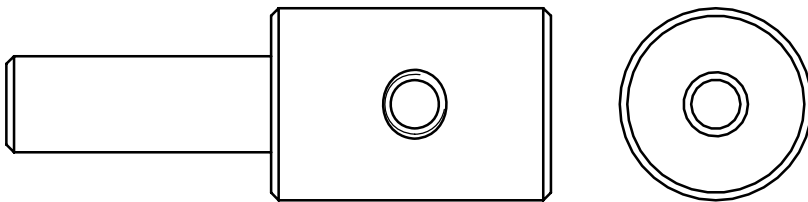

(A14)WEIGHT STACK CABLE (8260-009) QTY.1



(A15)ROUND ALLEN HEAD 5/32"x1/4"L PARTIAL THREAD QTY.4

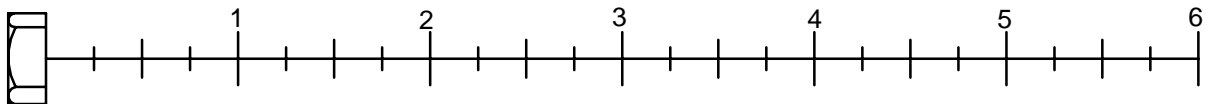

DPEC ASSEMBLY INSTRUCTIONS

HARDWARE ILLUSTRATION

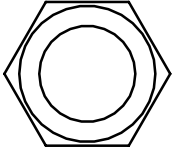

(B1) NYLON LOCK NUT 1/2" QTY.6

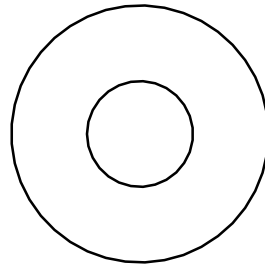
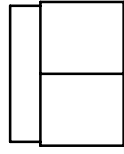

(C1) 1/2" (I.D.) FLAT WASHER Ø34 QTY.12

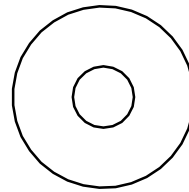

(C2) 5/16" (I.D.) FLAT WASHER Ø24 QTY.6

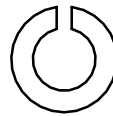

(C3) 5/16" SPRING WASHER QTY.6

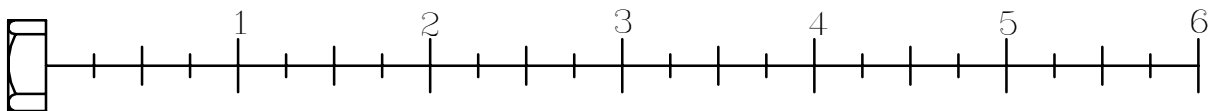

DPEC ASSEMBLY INSTRUCTIONS

FRAME HARDWARE ILLUSTRATION

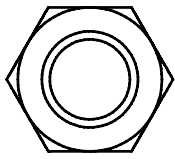

(B3) NYLON LOCK NUT 1/2" X 13 UNC X 8 T QTY. 1

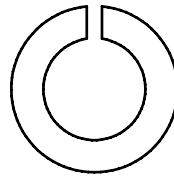
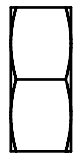

(C4) 1/2" SPRING WASHER QTY. 1

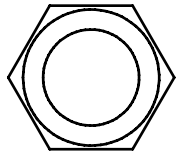

(B4) NYLON LOCK NUT 1/2" QTY. 3

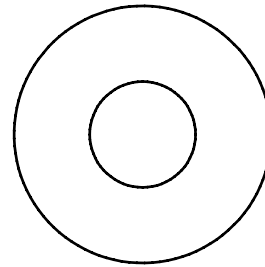
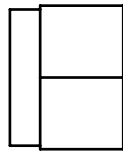

(C5) 1/2" (I.D.) FLAT WASHER Ø34 QTY. 4

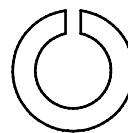

(C6) 3/8" SPRING WASHER QTY. 1

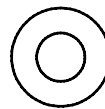
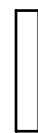

(C7) M6 (I.D.) FLAT WASHER Ø13 QTY. 20

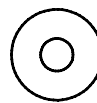

(C8) M4 (I.D.) FLAT WASHER Ø12 QTY. 2

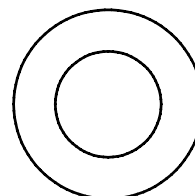
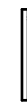

(C9) 1/2" (I.D.) FLAT WASHER Ø25 QTY. 2

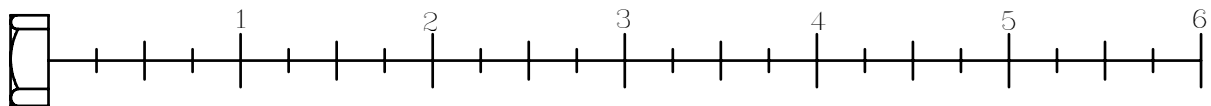

DPEC ASSEMBLY INSTRUCTIONS

HARDWARE ILLUSTRATION

| | | |
|------|--|--------|
| D1. | Ø3/4"X16L STEEL BUSHING (8110-066) | [2PCS] |
| D2. | Ø36XØ26.5X15L STEEL BUSHING (8130-160) | [2PCS] |
| D3. | Ø1" CU WASHER (8520-008) | [6PCS] |
| D4. | 2"X2" END CAP (9211-087) | [1PCS] |
| D5. | 58X116X2.5T FOOT CAP(9211-108) | [4PCS] |
| D6. | 58X116 END CAP(9211-112) | [3PCS] |
| D8. | 2"X2" RUBBER CANE CAP(9214-002) | [1PCS] |
| D9. | Ø3/4" SHAFT COLLAR(9211-046) | [2PCS] |
| D10. | Ø4" RUBBER DOUNT(9310-017) | [2PCS] |
| D11. | 95X250 RUBBER PAD(9310-060) | [3PCS] |
| D12. | Ø117 PULLEY(9213-010B) | [7PCS] |
| D13. | WEIGHT SELECTOR BAR(8210-042) | [1PCS] |
| D14. | TOP PLATE(8400-006) | [1PCS] |
| D15. | 3015mm STEEL CABLE(FDPECA) | [1PCS] |
| D16. | 3262mm STEEL CABLE(FDPECB) | [1PCS] |
| D17. | 1/2" BOLT CAP(9212-024) | [2PCS] |
| D18. | DPEC For DGYM Steel Cable(FDPECC) | [1PCS] |

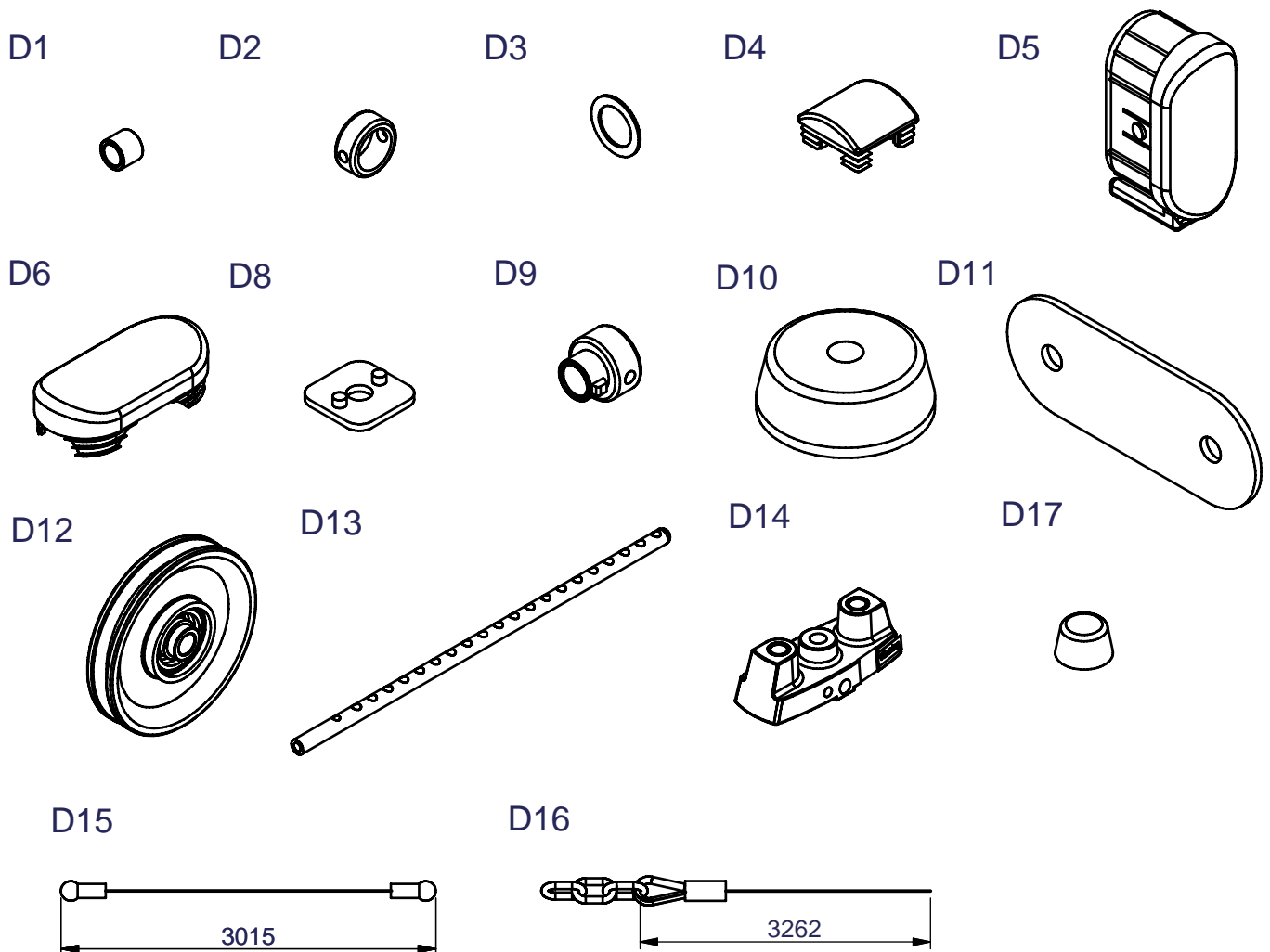

DPEC ASSEMBLY INSTRUCTIONS

PARTS ILLUSTRATION SHEET

A[1PCS]

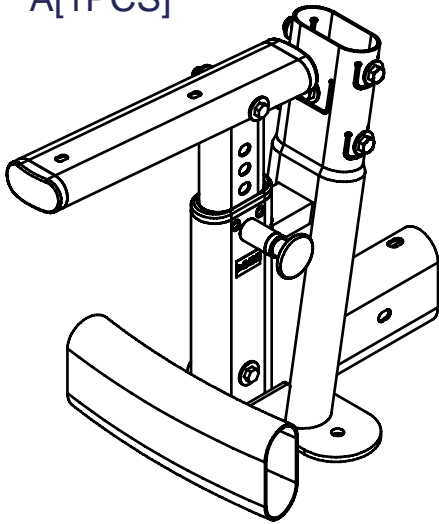

B[1PCS]

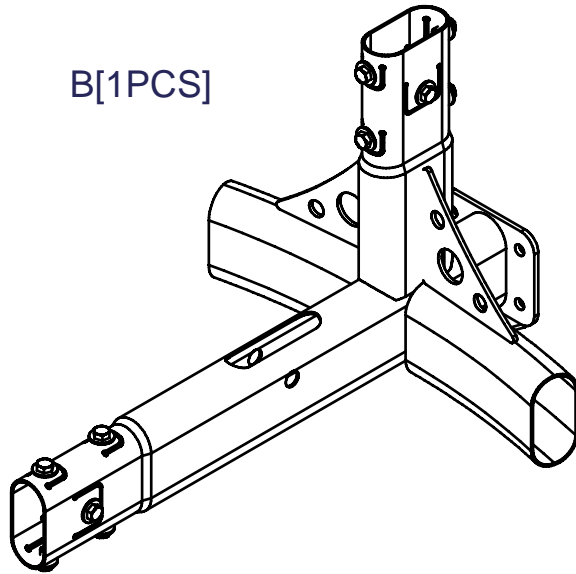

C[2PCS]

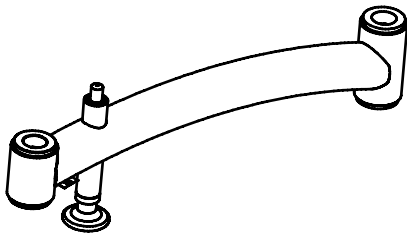

D[2PCS]

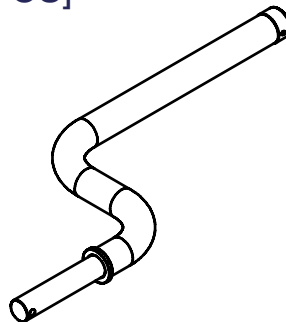

F[1PCS]

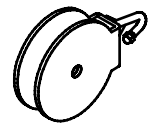

G[1PCS]

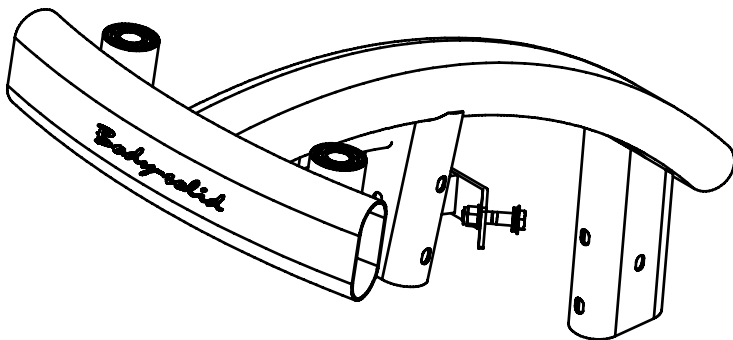

H[2PCS]

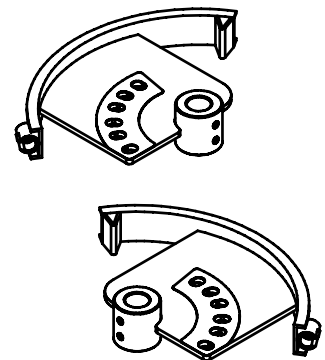

DPEC ASSEMBLY INSTRUCTIONS

PARTS ILLUSTRATION SHEET

I[1PCS]

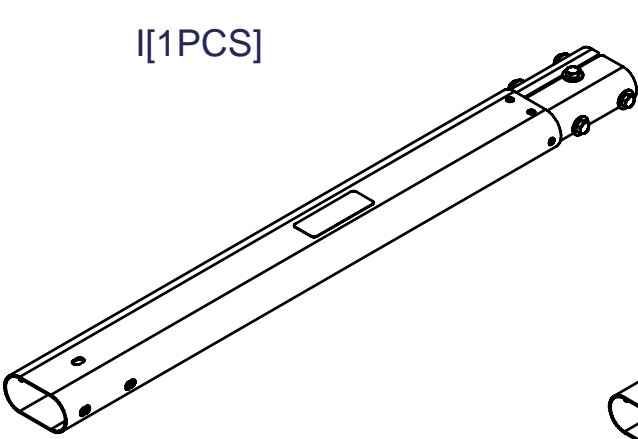

J[1PCS]

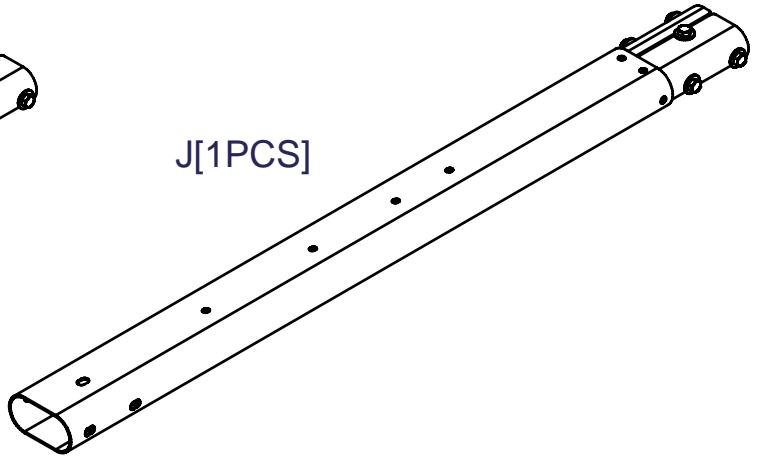

K[2PCS]
8220-135

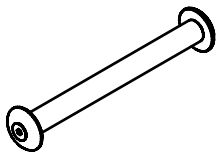

L[1PCS]
9111-057

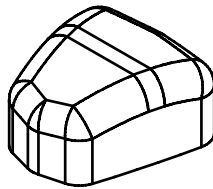

M[1PCS]
9111-058

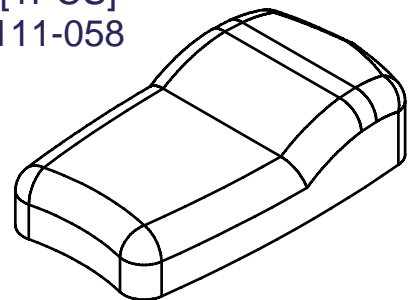

N[1PCS]
9121-055

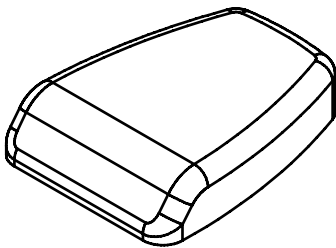

AA[2PCS]
8331-015

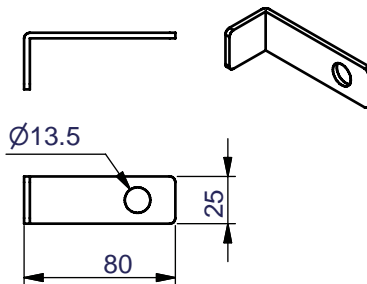

DPEC ASSEMBLY INSTRUCTIONS

FRAME PARTS ILLUSTRATION SHEET

O[1PCS]
8380-046

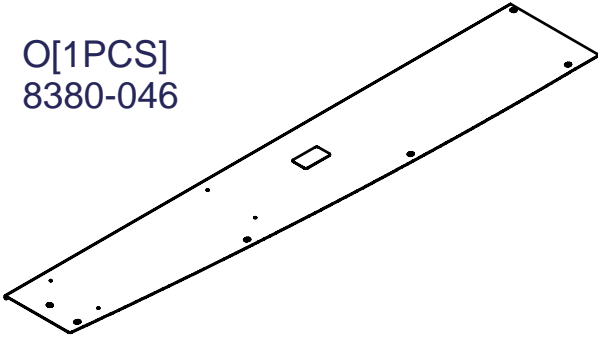

P[1PCS]
8380-047

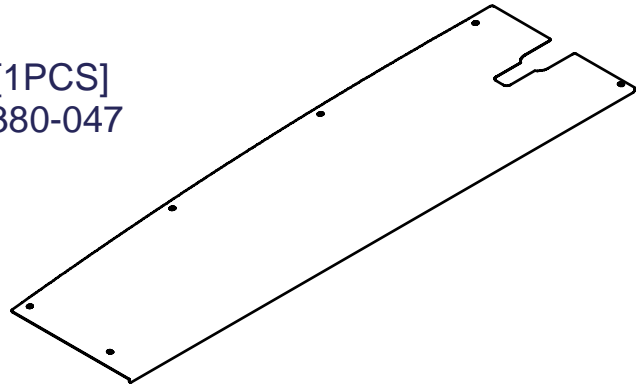

Q[1PCS]
8380-048

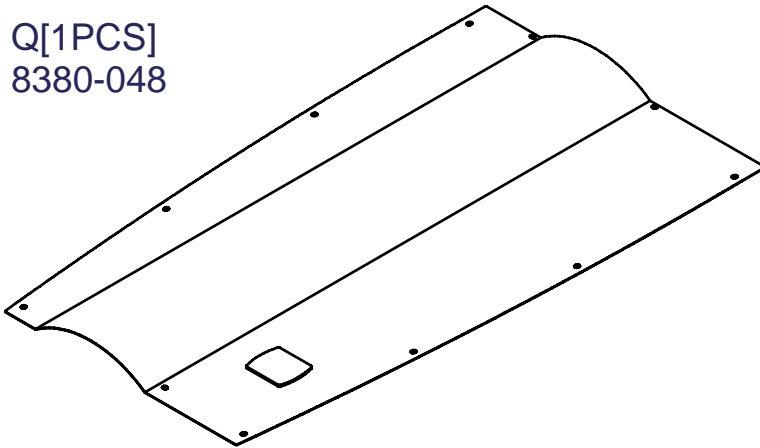

R[2PCS]
Ø3/4"X1425L

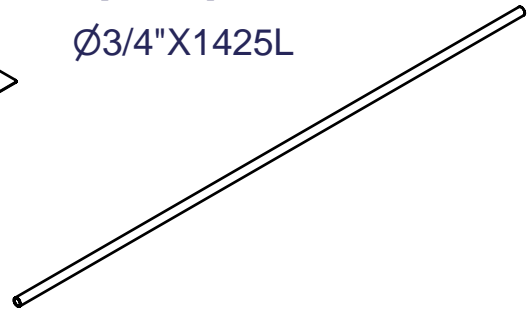

S[1PCS]
9211-111

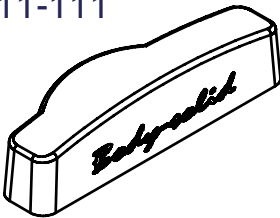

U[2PCS]
8313-144

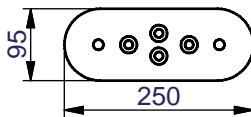

V[9PCS]
8321-040
both side

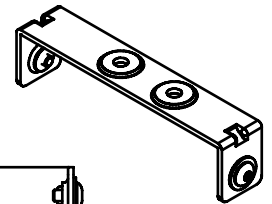
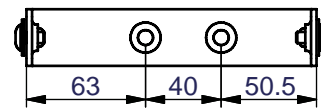

T[1PCS]
6610-002

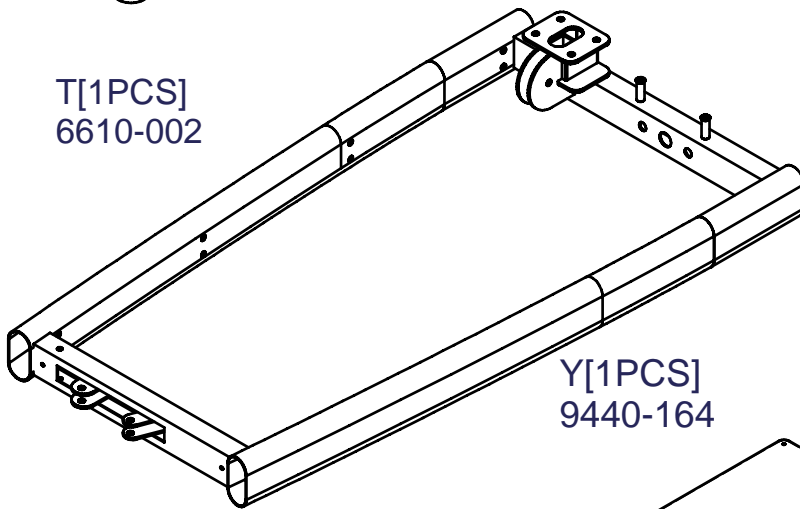

W[1PCS]
8321-040
one side

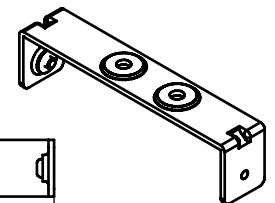
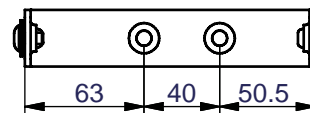

Y[1PCS]
9440-164

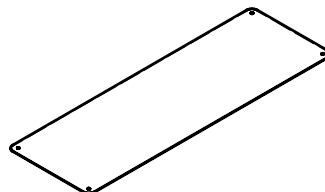

X[2PCS]
8321-040
one side

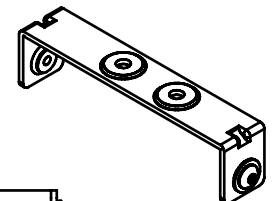
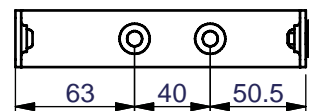

DPEC ASSEMBLY INSTRUCTIONS

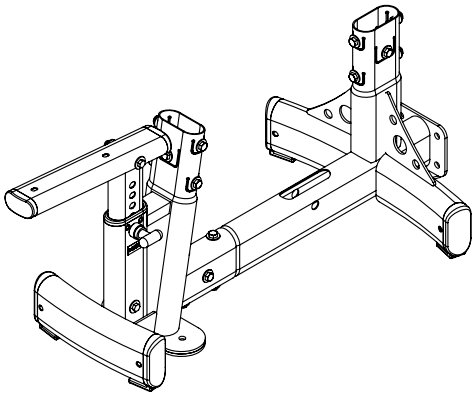

Above shows STEP 1
assembled and completed

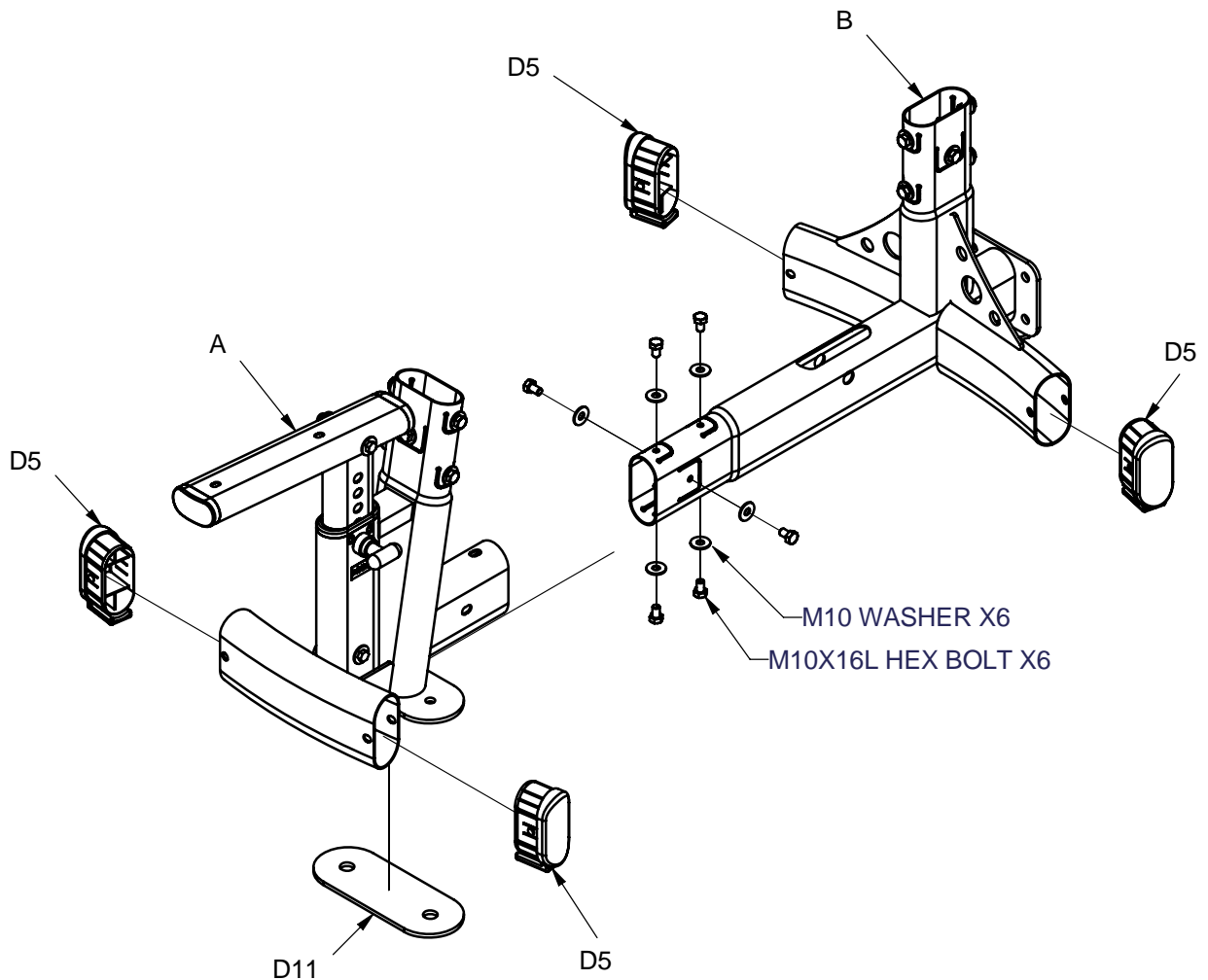

DPEC ASSEMBLY INSTRUCTIONS

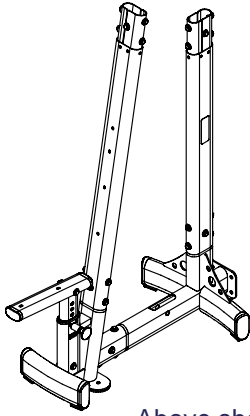

Above shows STEP 2
assembled and completed

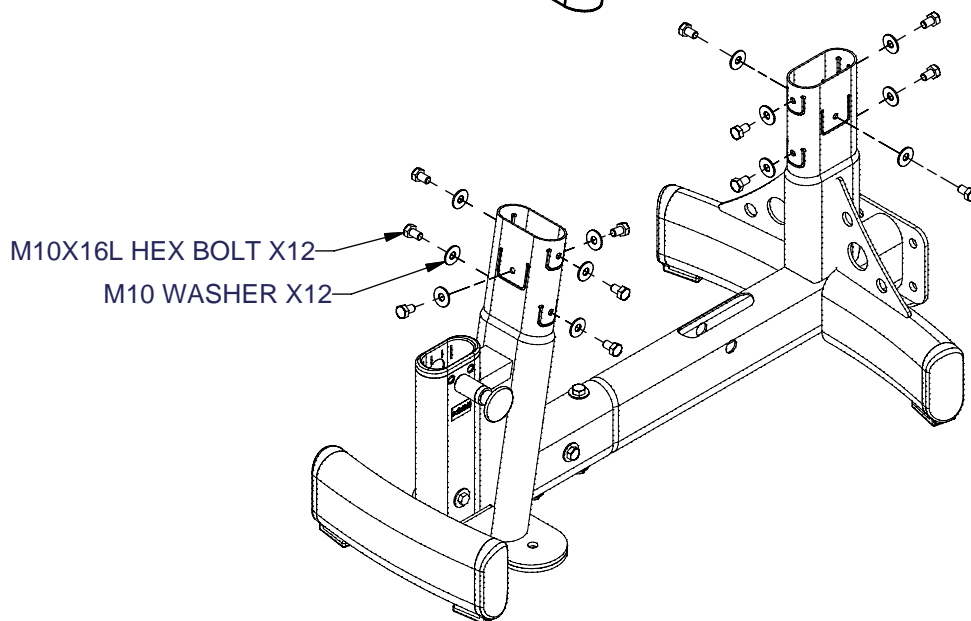
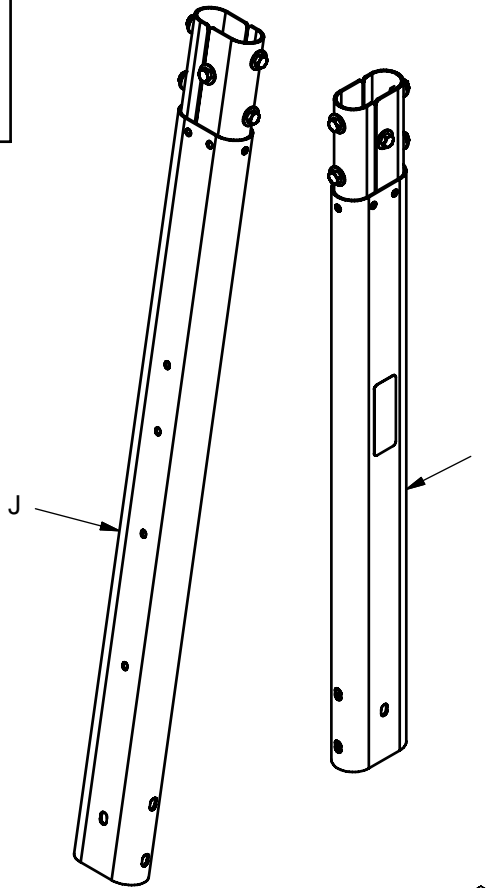

DPEC ASSEMBLY INSTRUCTIONS

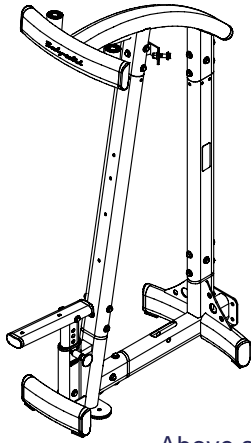

Above shows STEP 3
assembled and completed

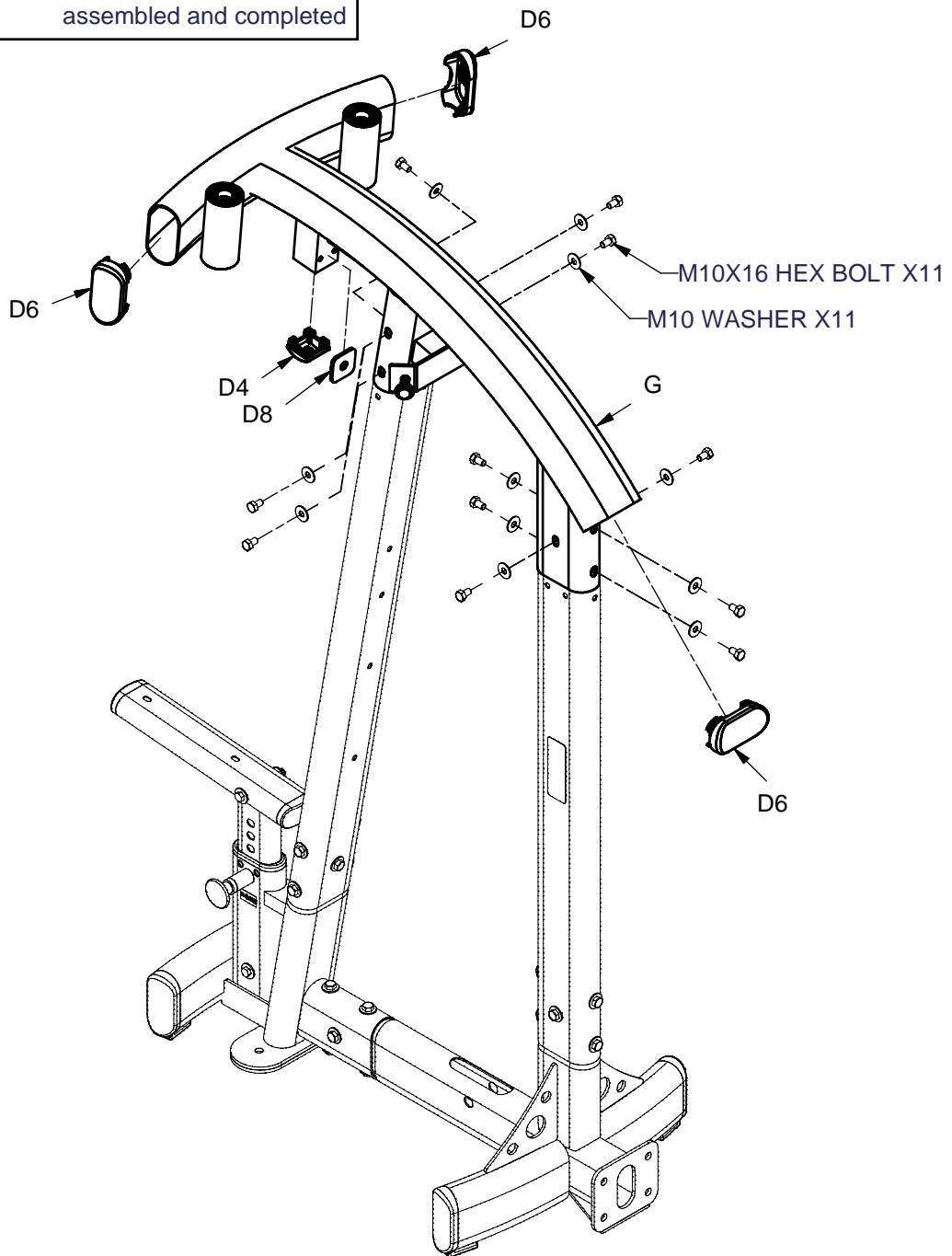

DPEC ASSEMBLY INSTRUCTIONS

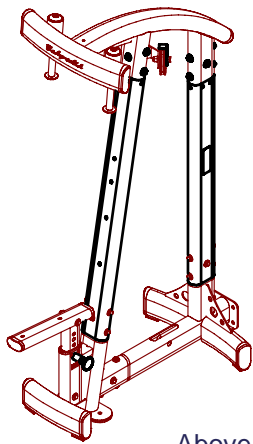

Above shows STEP 4
assembled and completed

M10X25L CONE BOLT X4

Ø50 CAP X4

K

K

1/2" NYLON LOCK NUT X2

1/2" WASHER Ø25 X2

D12X2

AAX2

1/2"X2 1/4" HEX BOLT X2

1/2" WASHER Ø25 X2

Repeat assembly for left side pulley

DPEC ASSEMBLY INSTRUCTIONS

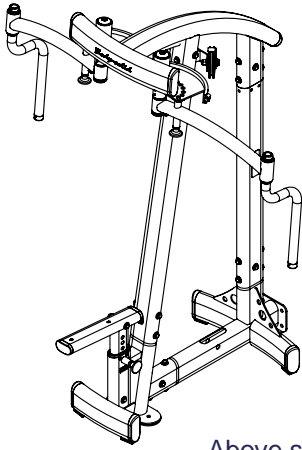

Above shows STEP 5
assembled and completed

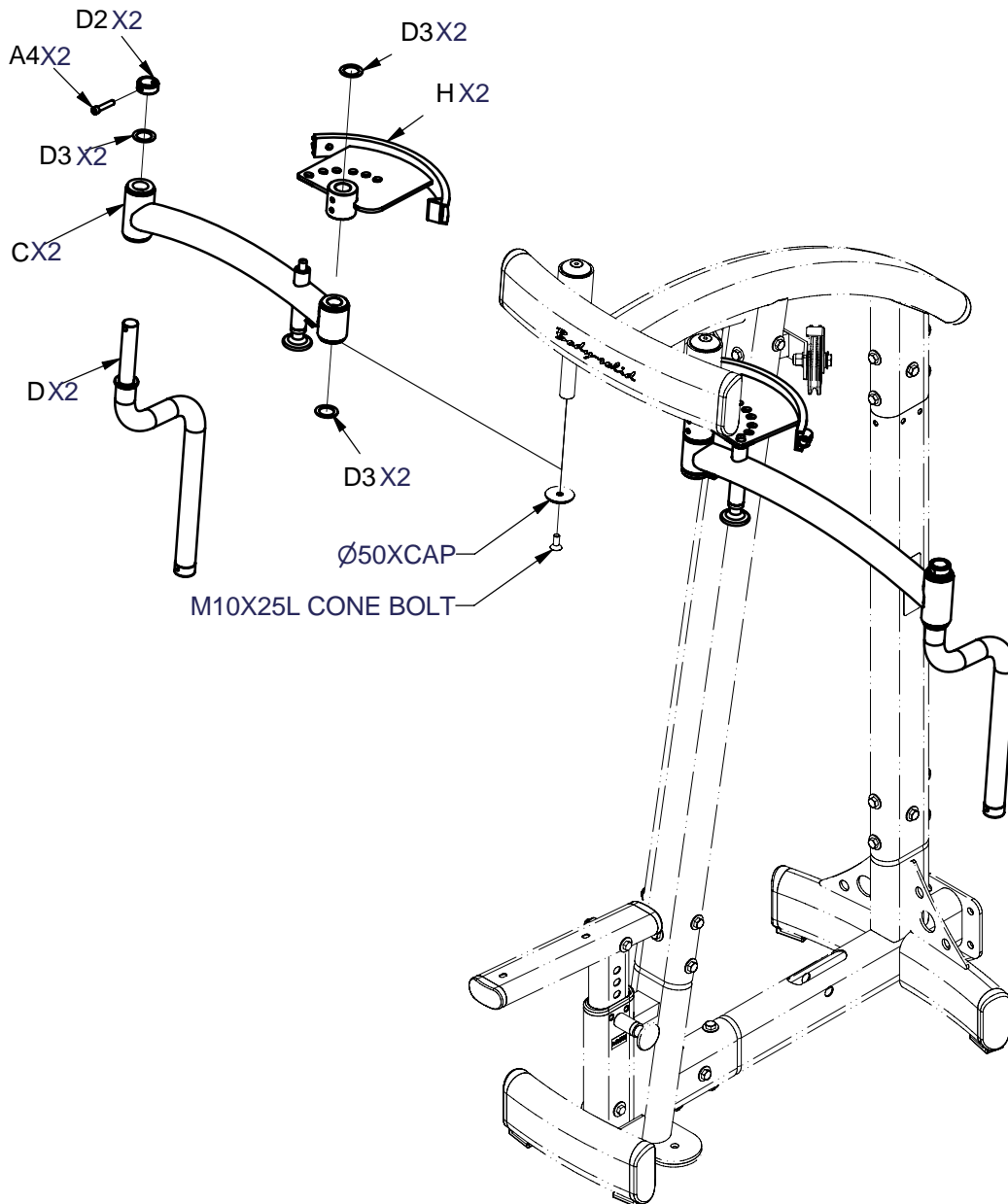

DPEC ASSEMBLY INSTRUCTIONS

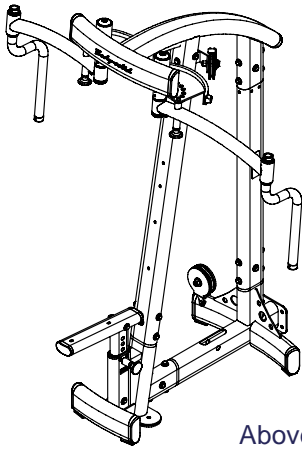

Above shows STEP 6 assembled and completed

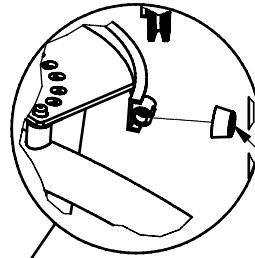

Press cap over cable end holder

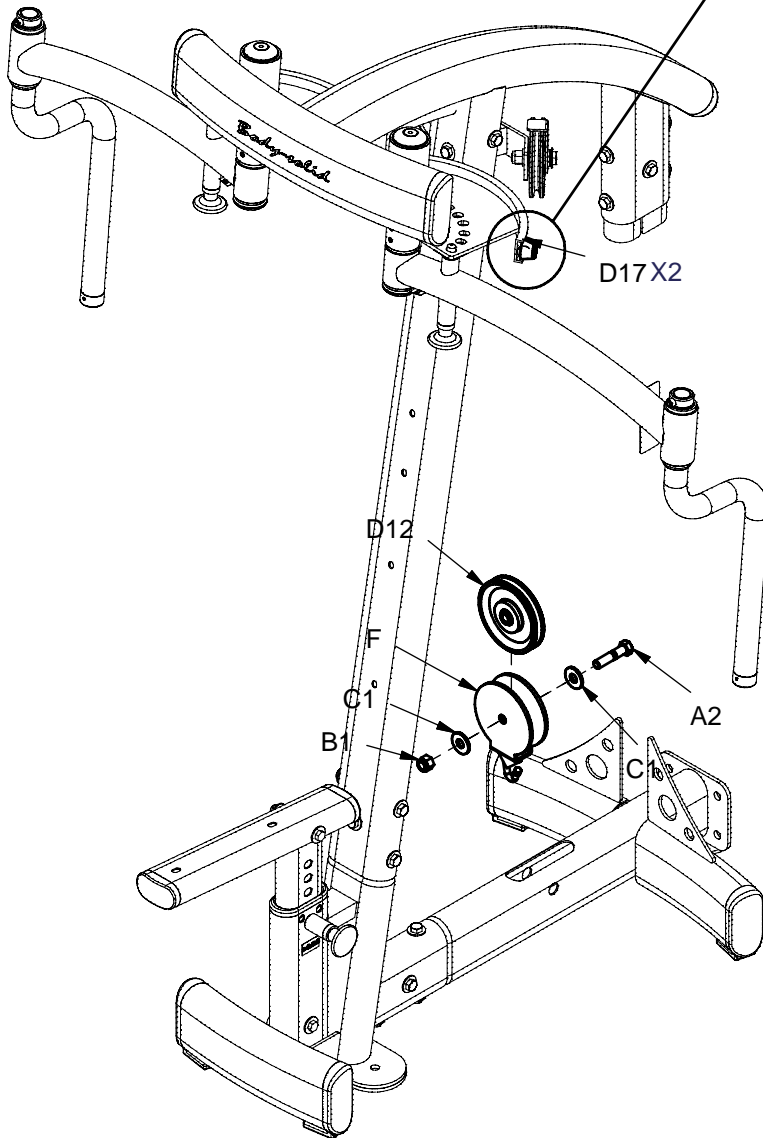

D17X2

D12

F

C1

B1

A2

C

DPEC ASSEMBLY INSTRUCTIONS

Cable to match illustration

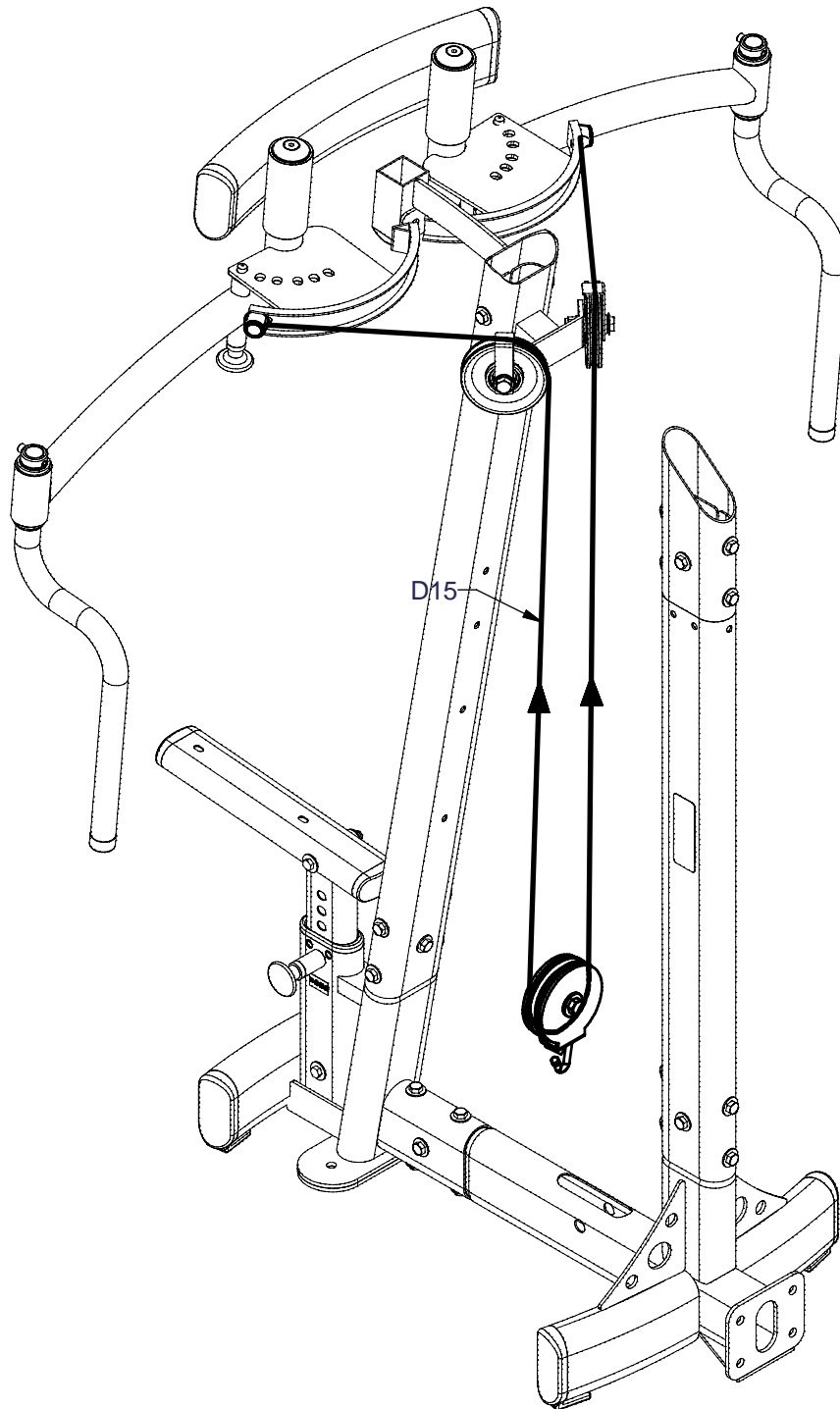

DPEC ASSEMBLY INSTRUCTIONS

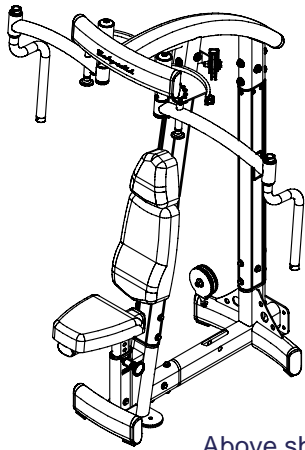

Above shows STEP 7
assembled and completed

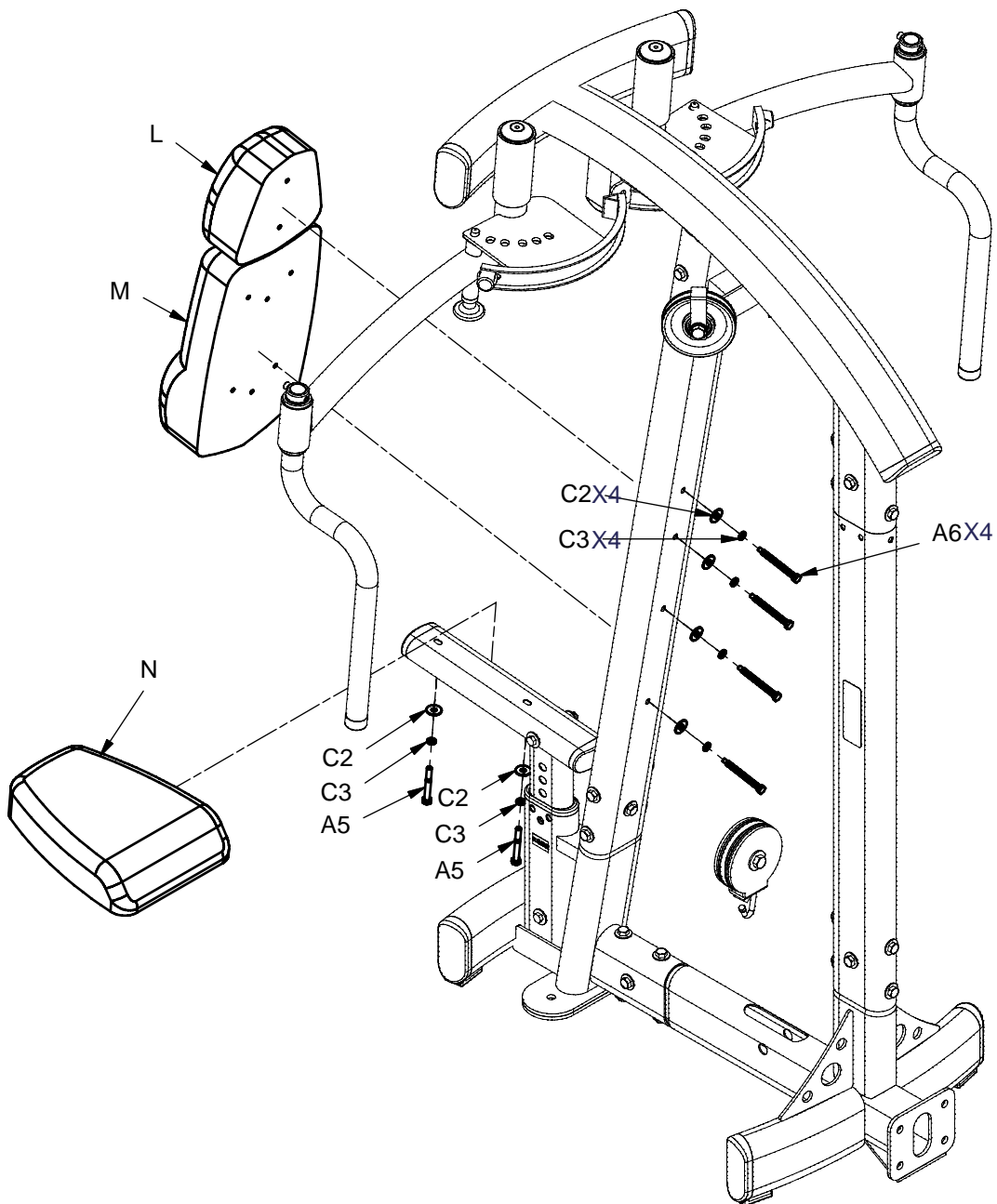

DPEC ASSEMBLY INSTRUCTIONS

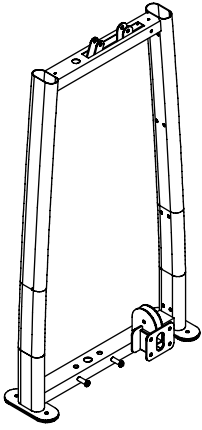

Above shows STEP 8
assembled and completed

DPEC single weight stack assembly instructions

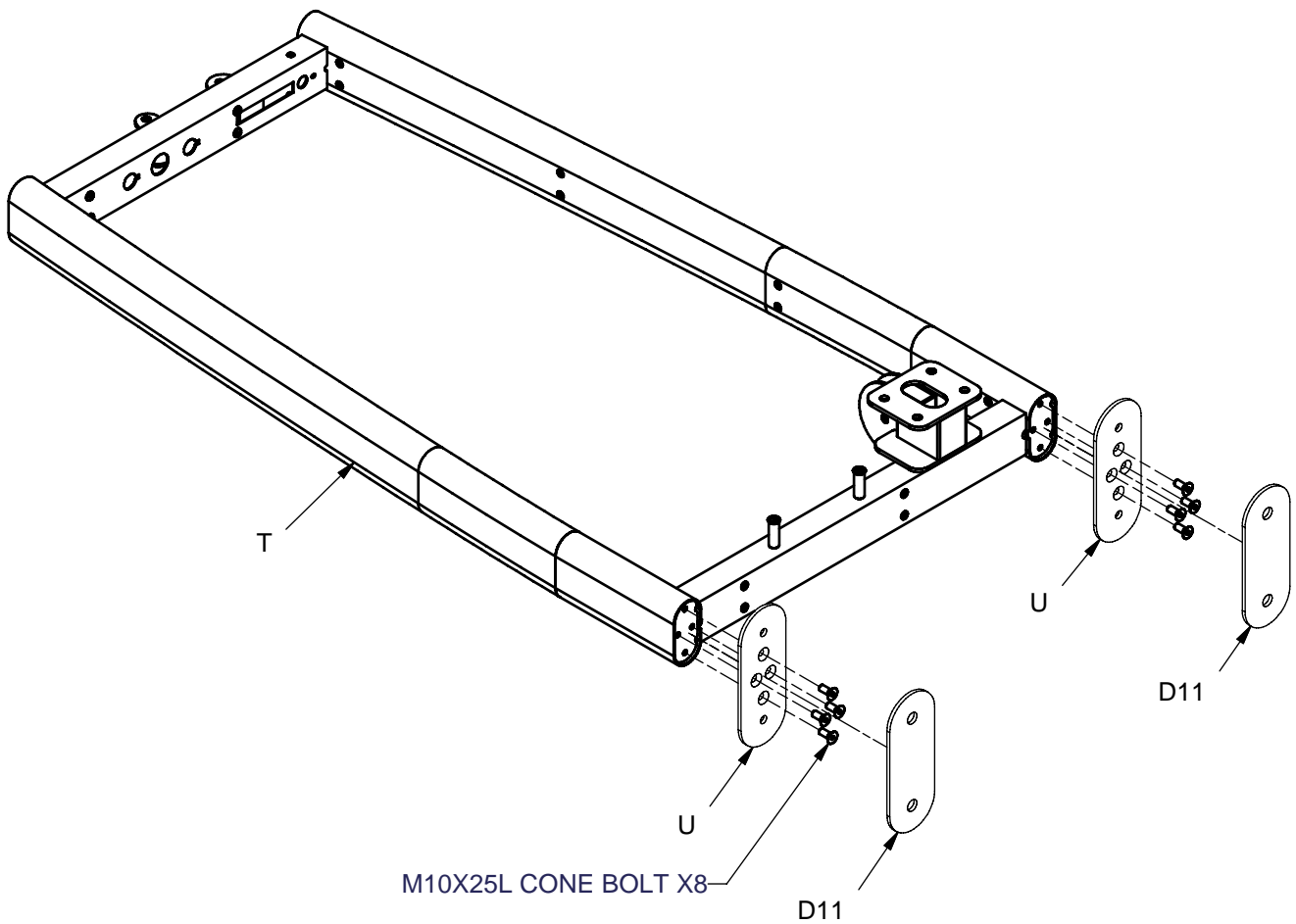

DPEC ASSEMBLY INSTRUCTIONS

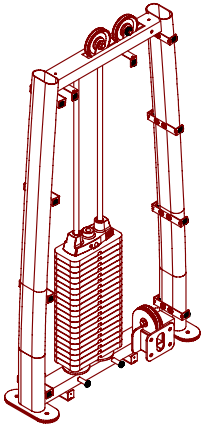

Above shows STEP 9 assembled and completed

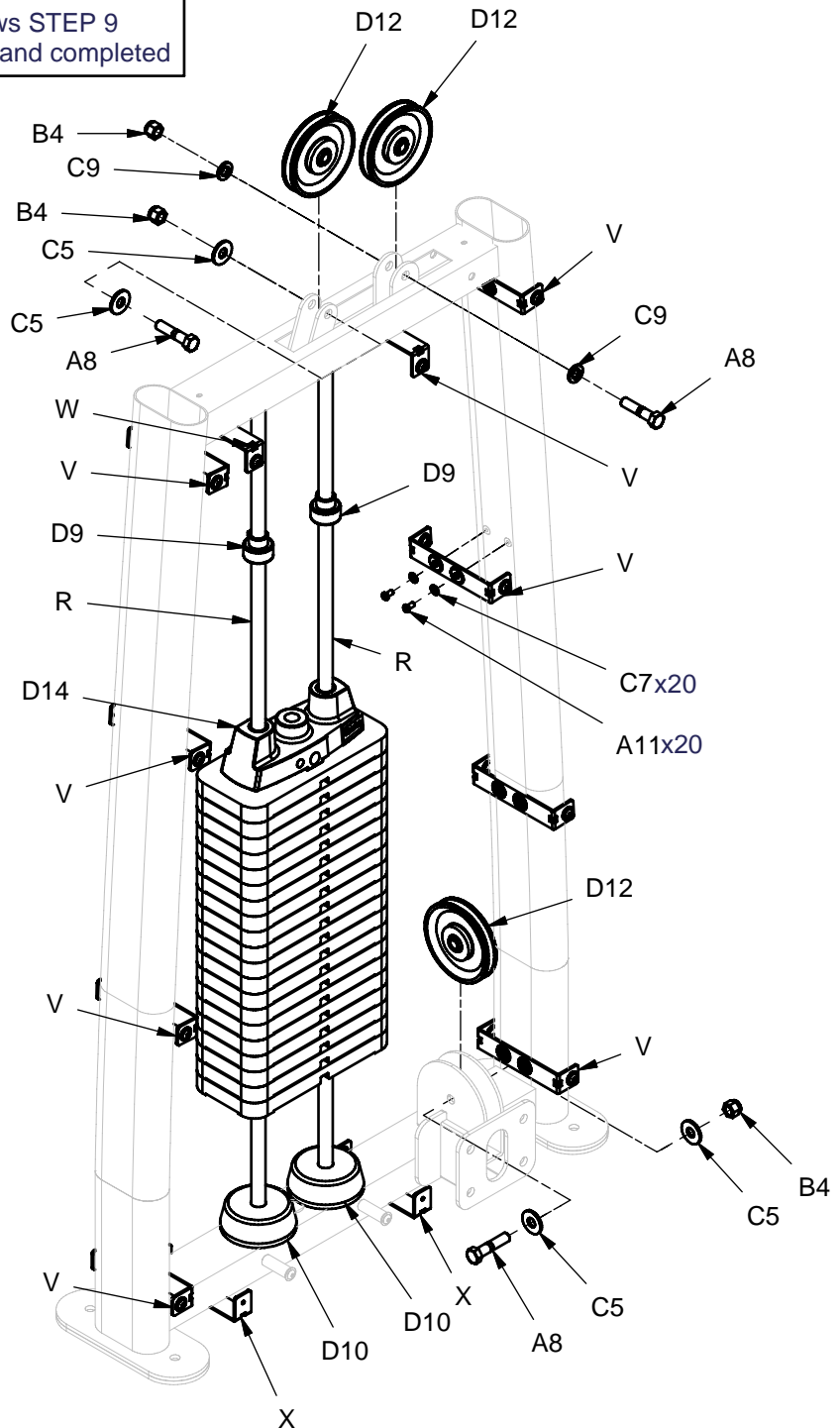

DPEC ASSEMBLY INSTRUCTIONS

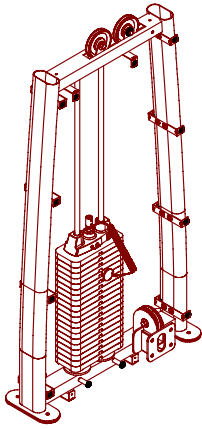

Above shows STEP 10
assembled and completed

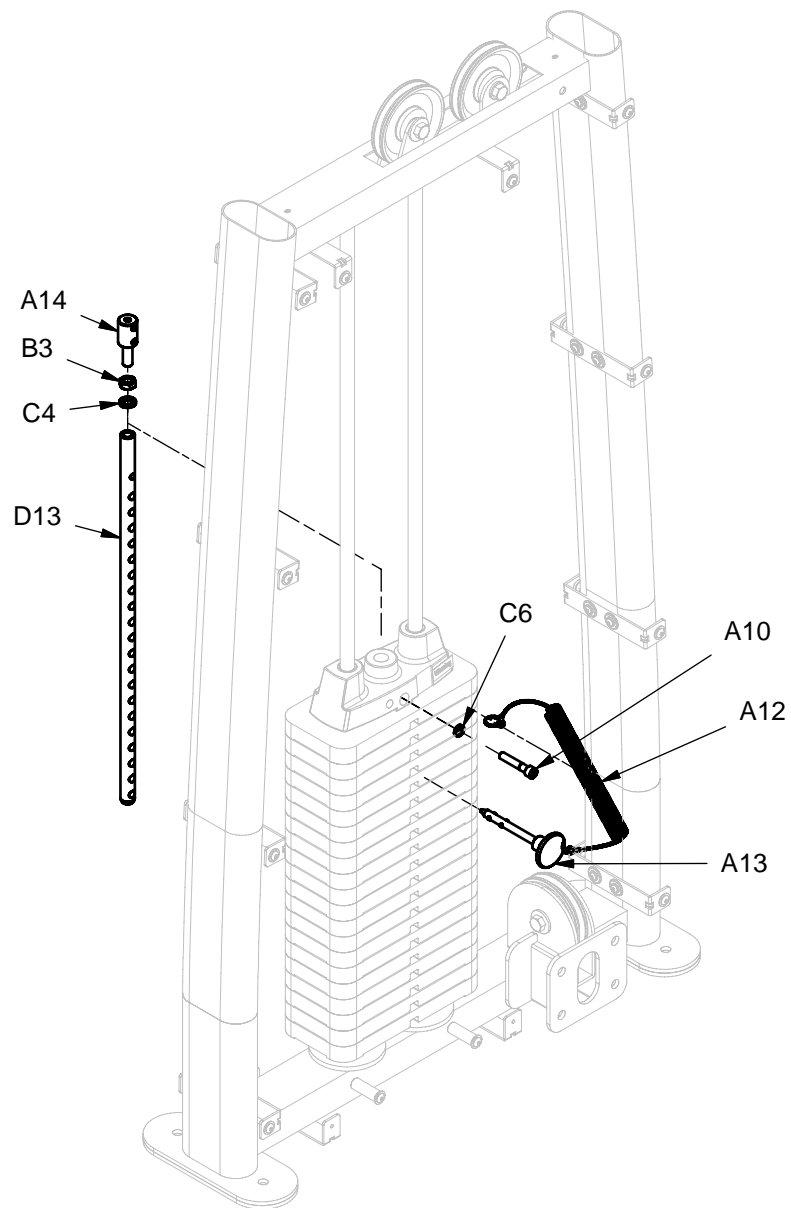

DPEC ASSEMBLY INSTRUCTIONS

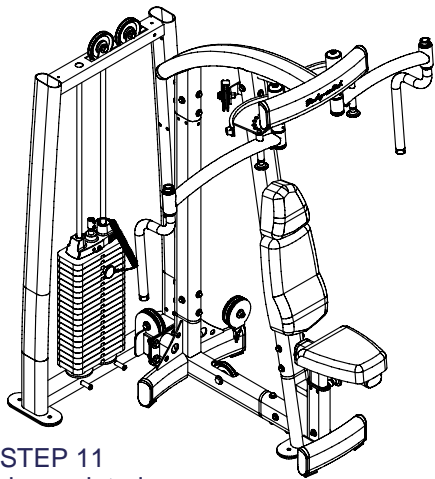

Above shows STEP 11
assembled and completed

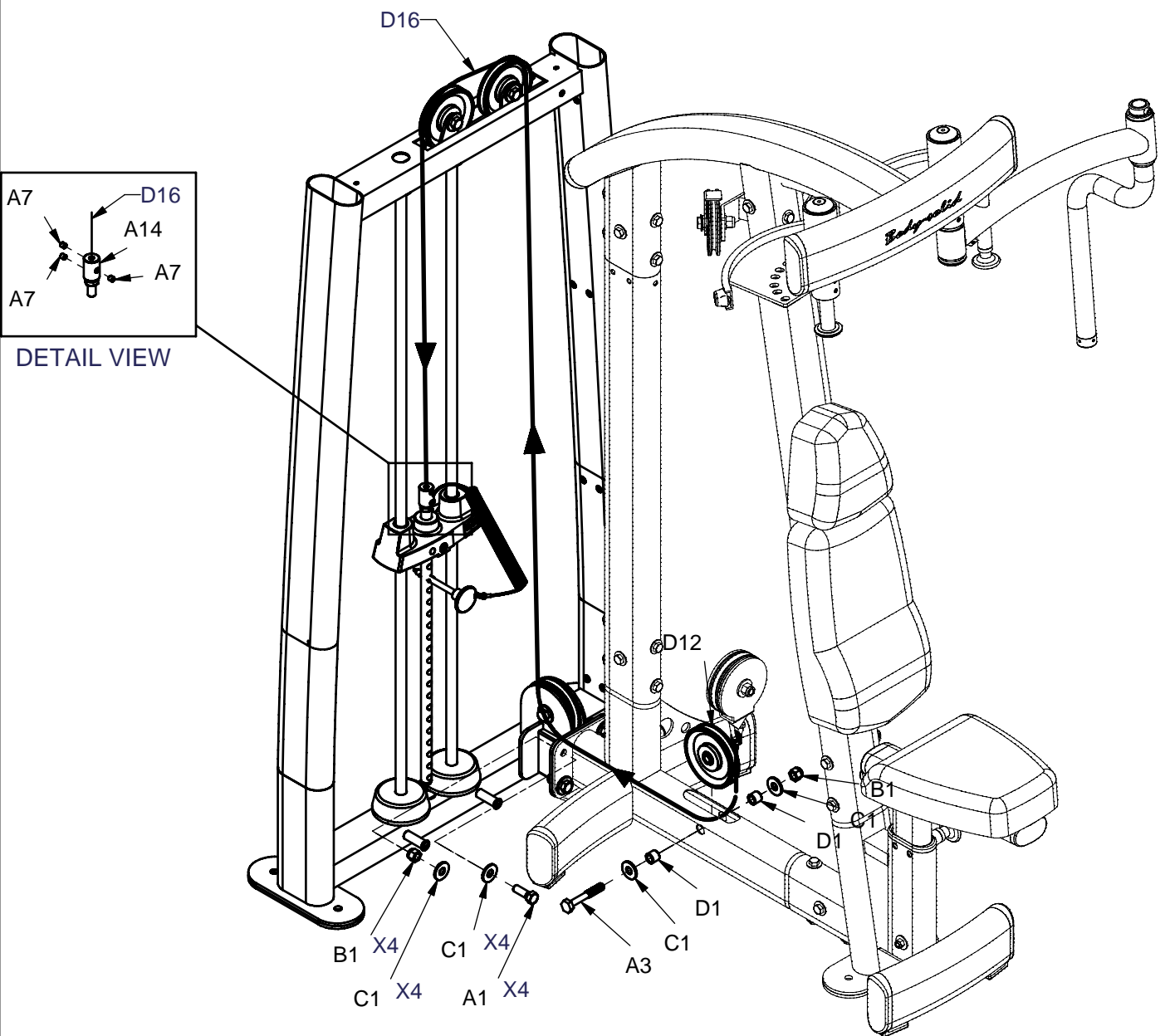

A7
D16
A14
A7
DETAIL VIEW

DPEC ASSEMBLY INSTRUCTIONS

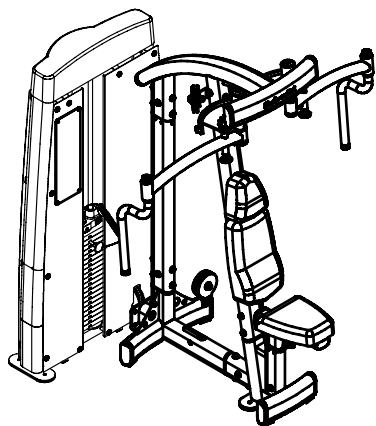

Above shows STEP12
assembled and completed

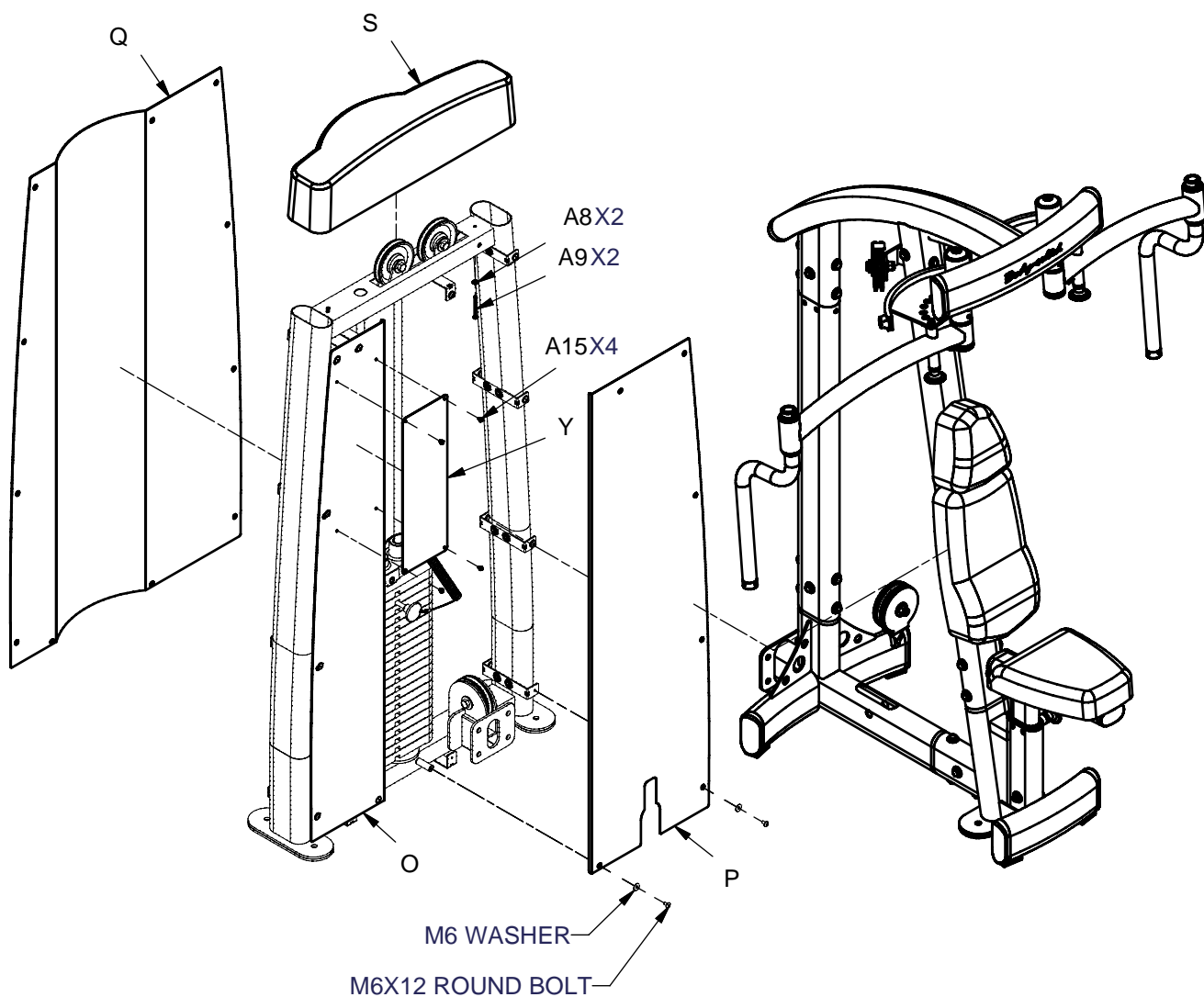

DPEC ASSEMBLY INSTRUCTIONS

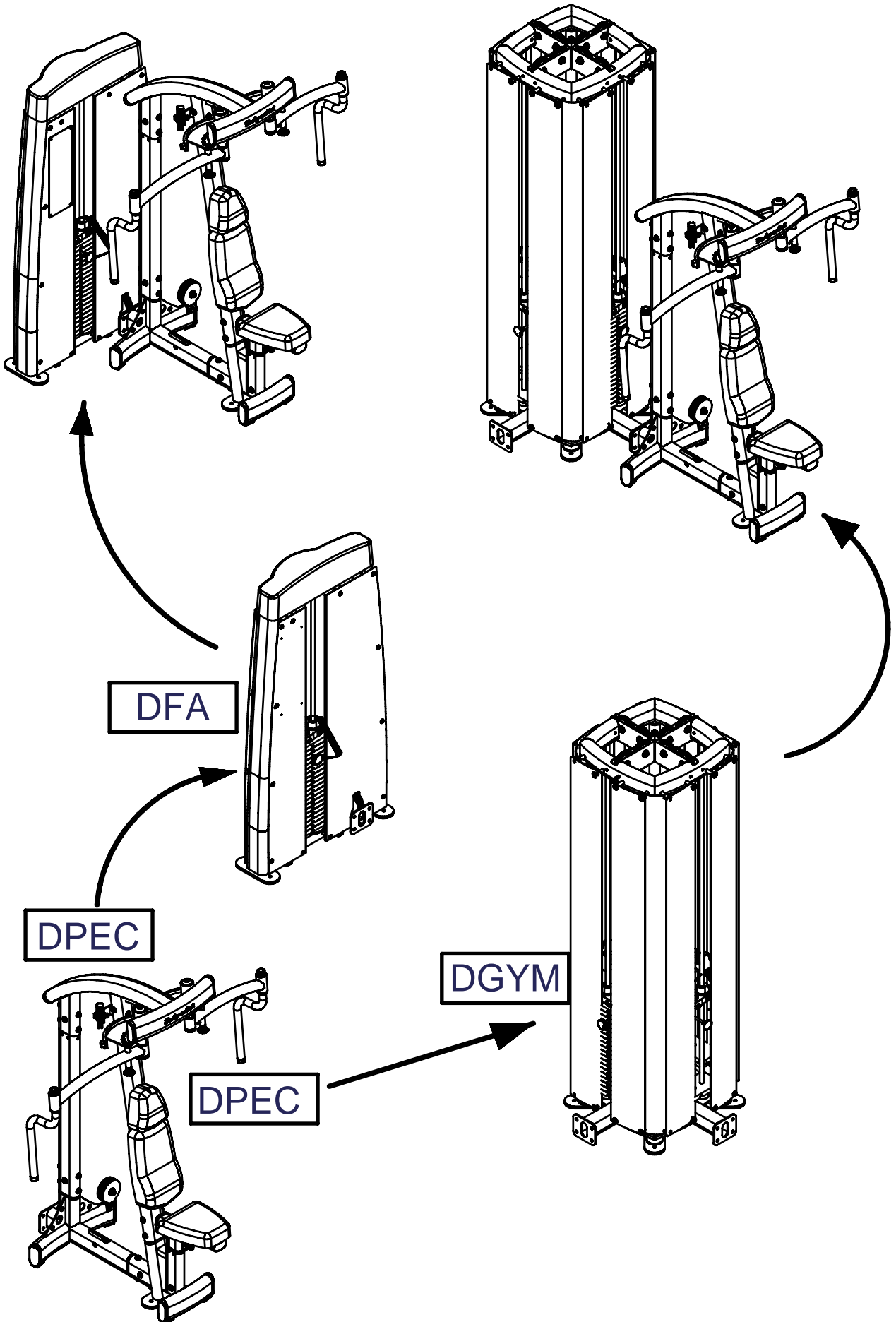

DPEC ASSEMBLY INSTRUCTIONS

Cable to match illustration

