

371-042 EARLY YEARS PLAYSCAPE (PERMANENT)

Page 1 of 3
Rev 02/20/2020

IMPORTANT

Please retain this information sheet in your files. It contains important replacement parts information. All equipment should be installed in accordance with these instructions.

It is important to use and maintain all public playground equipment properly. Playground equipment, which is improperly maintained, can cause serious injury. Periodic inspections, maintenance, repair and/or replacement of damaged parts is necessary for safe operation of equipment. Appropriate publications, available at no charge, from the consumer product safety commission, include a "handbook for public playground safety."

You can receive your free copy by calling toll free 1-800-727-8180.

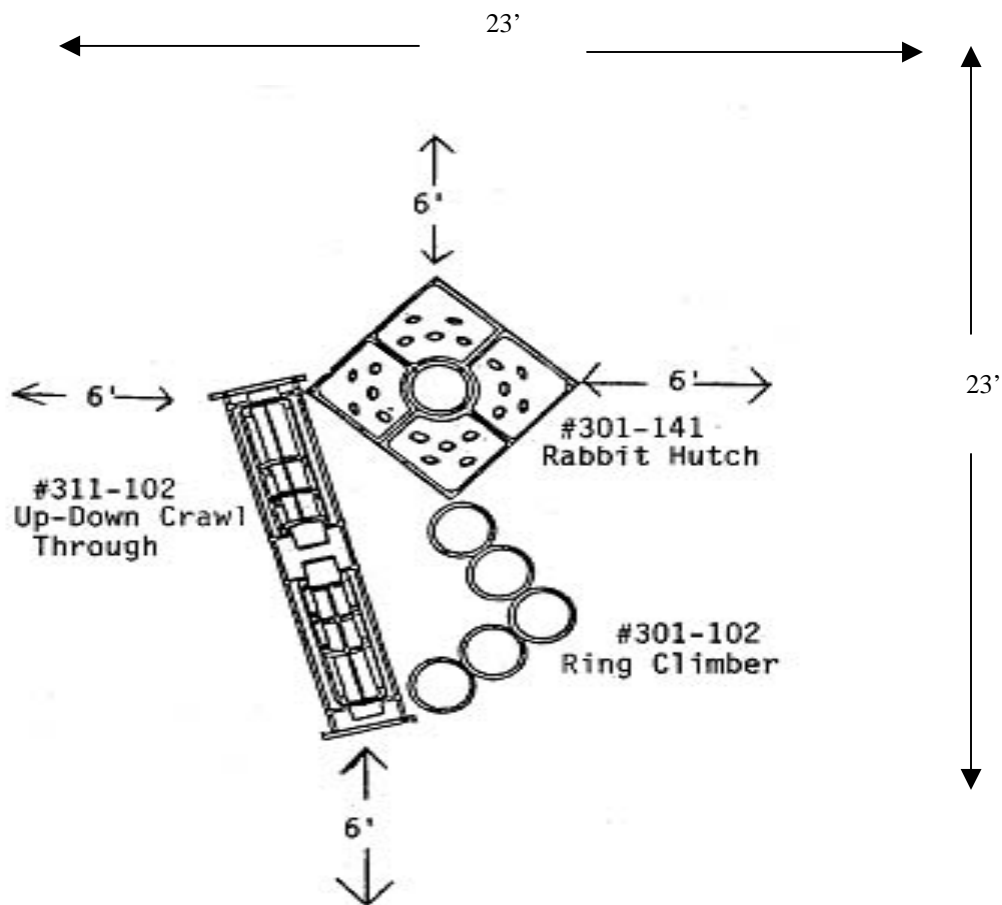

The Early Years Playscape consists of three popular individual climbers that have been grouped together to form one integral climber. The total grouping allows children to proceed from one climber to another in an appealing environment of webs, shelters, ladders and open tunnels, which invite dynamic, make believe games that are joyous and socially cooperative.

Playscape play is safely secured at the youngster's own ability level with child-scaled hand and foot holds, everywhere.

The child, not the equipment, is in control. As a result, ever changing games always succeed and nurture the self-confidence so vital to building ego-satisfaction, character, and the eagerness to enrich life with physical expression.

Spacing and positioning of the individual units can be modified as desired, keeping in mind the Consumer Product Safety Commission guidelines.

GENERAL USE/FALL ZONE & FOOTING RECOMMENDATIONS

Stationary & portable equipment – use/fall zones should extend a minimum of 6 feet in all directions from the perimeter of the equipment ground space. This area should be covered with the required amount of resilient safety surfacing material. For some equipment – use/fall zones can overlap. See Consumer Product Safety Commission guidelines.

Diameter & depth of footings illustrated are satisfactory in most application for pipe sizes up to 2 3/8" diameter. Varying soil & climatic conditions may require deeper & heavier footings in some areas. Check local building codes.

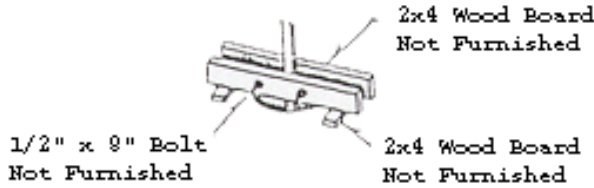
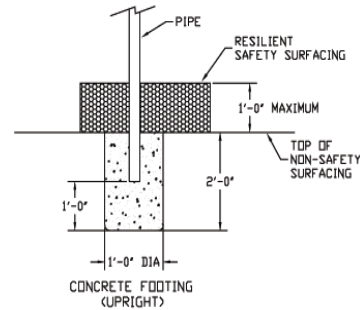
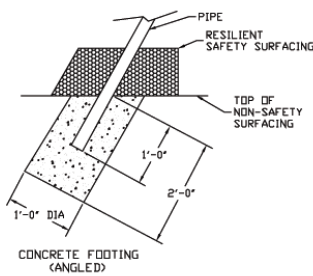

Suggested Bracing Method

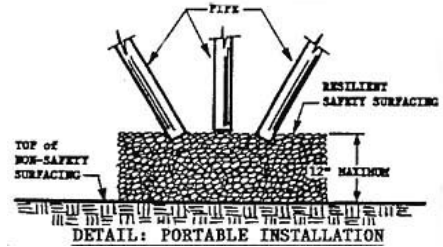

GENERAL ASSEMBLY INSTRUCTIONS:

Check all the parts and hardware with the packing list to be sure you have received everything needed to assemble this product. **CONTACT YOUR LOCAL DISTRIBUTOR OR SPORTSPLAY WITH NOTIFICATION OF ANY MISSING OR DAMAGED PARTS.** Contact must be made within ten days of receipt of your order.

Only hand tighten nuts & bolts on initial assembly. Final tightening should be done **EVENLY** after final assembly when unit has been plumbed & leveled. After assembly is complete, **ANY ENDS OF BOLTS PROTRUDING BEYOND NUTS SHOULD BE CUT OFF AND/OR PEENED OVER TO REMOVE ANY SHARP PROJECTIONS.** Go over entire unit to file smooth any sharp edges or projections that may have been caused by rough handling in shipping or installation.

GENERAL MAINTENANCE INSTRUCTIONS:

Check **MONTHLY** for loose bolts, damaged or broken parts. Tighten and/or replace immediately.

SPECIFIC ASSEMBLY INSTRUCTIONS:

NOTE:

REFER TO EACH INDIVIDUAL INSTALLATION DRAWING OF PRODUCT FOR ASSEMBLY INFORMATION, HARDWARE BAG, AND PACKING LIST.