

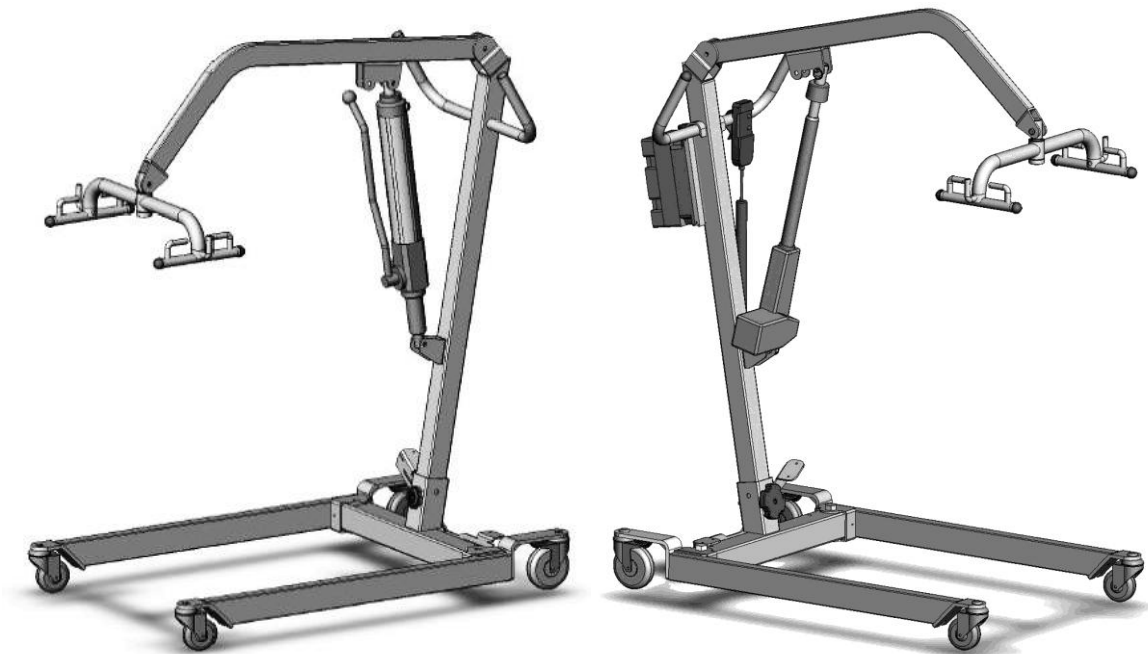

**HYDRAULIC OR BATTERY OPERATED  
MODEL : 400H / 400EL / 400LK**



***The Future of Homecare Lifting is Here!***

## **Thank you for choosing the BestLift 400**

To better serve you, please record the following information:

Dealer Name: \_\_\_\_\_

Telephone: \_\_\_\_\_

Serial #: \_\_\_\_\_

Date of Purchase: \_\_\_\_\_

## **INSPECT YOUR MERCHANDISE**

Upon receipt of your Bestcare Lift, verify that all merchandise is complete and free from any shipping damage. Refuse delivery if the packaging appears to be badly damaged. If the merchandise is received damaged or is missing components, contact the shipping company immediately and file a claim.

# SAFETY INSTRUCTIONS



The BestLift Series of full body patient lifts reflect innovative state of the art design to increase user mobility. Your BestLift patient lift will provide years of service if it is properly maintained as any piece of electric/mechanical equipment requires.

Pay careful attention to the following important information regarding the care, maintenance, and operation of the patient lift. Carefully read these instructions before assembling the lift, or attempting to lift a user with the device.

Always keep the Owner's Manual available with the lift.

## DEFINITIONS

### & SYMBOLS

In this manual the **user** refers to the patient or resident and may be used interchangeably at different times. Caregiver refers to the operator or person who is assisting with the transfer.

Symbols used in this manual and their meanings:



Warning! Failure to heed this warning may result in damage to the product or serious injury to the operator and/or user.



Important instructions! Read and understand the instructions in the manual before using the product.



Note! Important information concerning the product and/or its safe and correct usage follows.



## **WARNING!**

- **MAXIMUM Weight Capacity: 400 pounds**
- **NEVER** exceed the maximum lifting capacity indicated on the patient lift or any accessory used in conjunction with the lifter.
- Take special care with users that cannot provide assistance while being lifted. I.e. patients who are comatose, spastic, agitated, or otherwise severely handicapped.
- **DO NOT** attempt to lift and transfer a user without their nurse or doctor's prior approval.
- **DO NOT** place any objects between the sling and the user. I.e. cushion padding, etc.
- **DO NOT** use slings that are not specifically designed tested or approved for use on Bestcare patient lifts.
- **DO NOT** lock caster brakes during lifting.
- Close the base before moving the patient lift.
- **ALWAYS** keep the suspended user centered between the base legs.
- **DO NOT** attempt to roll the lift and casters over floor obstacles when in use.
- **DO NOT** use patient lift for transportation.
- **NEVER** interfere with a lift and transfer in process unless instructed to do so.
- **NEVER** leave the user unattended during lifting.
- **DO NOT** attempt to repair or replace parts and components that are not designed, tested or approved for use on Bestcare patient lifts.

Before attempting to lift anyone, please practice operating the lift. Prior to the actual lift and transfer procedure, read and study the instructions for proper and safe operation of the patient lift. Be able to explain the entire lifting procedure to the user as well as answer any questions they may have concerning the procedure.

# BestLift PL400H SERIES

---

**Retrofit to Electric by ordering Upgrade Kit**

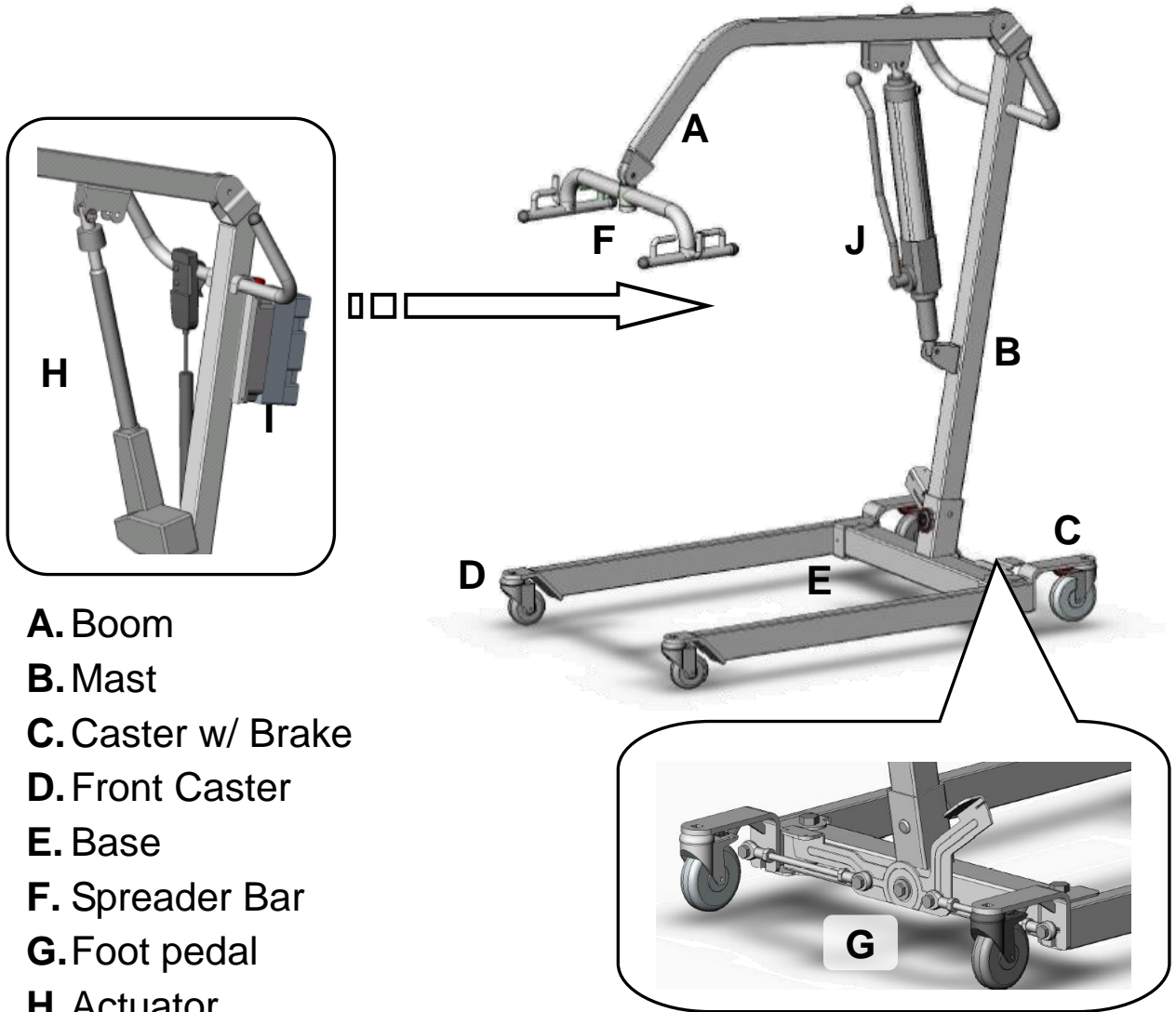

- A.** Boom
- B.** Mast
- C.** Caster w/ Brake
- D.** Front Caster
- E.** Base
- F.** Spreader Bar
- G.** Foot pedal
- H.** Actuator
- I.** Control Box
- J.** Hydraulic Pump for model PL400H\*

*\*Interchangeable with electric actuator available with the electric upgrade kit.*

## BestLift PL400H OVERVIEW

1. Carefully unpack box saving box and packaging.
2. Follow owner's manual for assembly and use of BestLift 400H.
3. Lock wheels to keep Base stationary.
4. Slide Mast into square sleeve located at rear and center of Base.
5. Fasten the Mast to the Base with the Bolt, Washer, and Black Hand Nut provided. Tighten and secure the Mast by hand.
6. Fasten Boom to Mast using the Bolt, Washer, and Black Hand Nut provided. Tighten and secure the Mast by hand.
7. Attach Spreader Bar to Boom with Keeper Pin and key ring provided.
8. Attach bottom Hydraulic piston rod to the Mast with Keeper Pin and key ring then attach top Hydraulic piston rod to the Boom in the same fashion. See picture below.



## BestLift PL400EL OVERVIEW

1. Carefully unpack box saving box and packaging.
2. Follow owner's manual for assembly and use of BestLift PL400EL.
3. Lock wheels to keep Base stationary.
4. Slide Mast into square sleeve located at rear and center of Base.
5. Fasten the Mast to the Base with the Bolt, Washer, and Black Hand Nut provided. Tighten and secure the Mast by hand.
6. Fasten Boom to Mast using the Bolt, Washer, and Black Hand Nut provided. Tighten and secure the Boom by hand.
7. Attach Spreader Bar to Boom with Keeper Pin and key ring provided.
8. Attach Electric Actuator bottom end to the Mast with Keeper Pin and key ring then attach Electric Actuator top end to the Boom in the same fashion. See picture below.
9. Hang Control Box on Lift Handle Bars and plug in the Electric Actuator, Hand Control and Charger

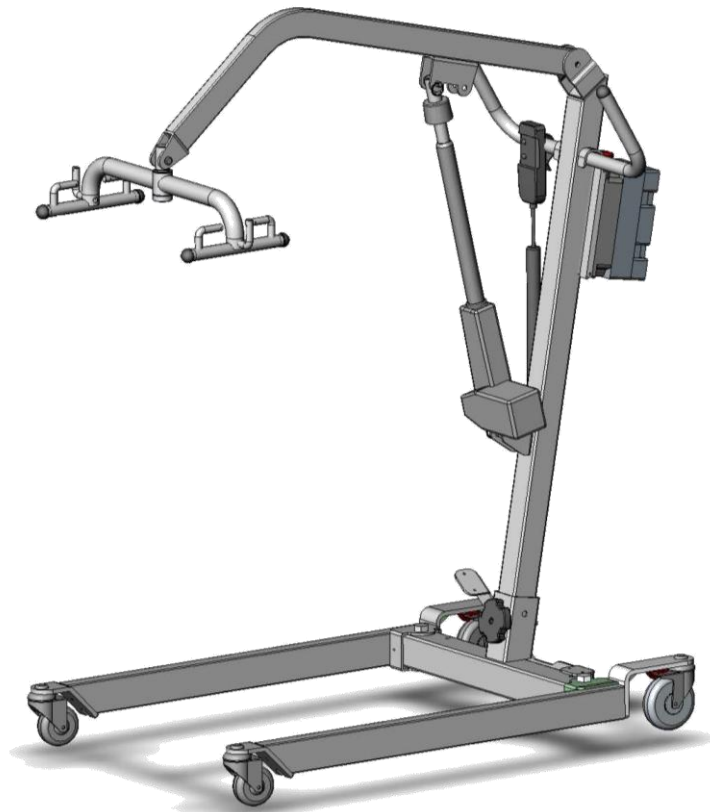

# ASSEMBLY

---

## ASSEMBLY OVERVIEW



**A.** Unpack components for assembly

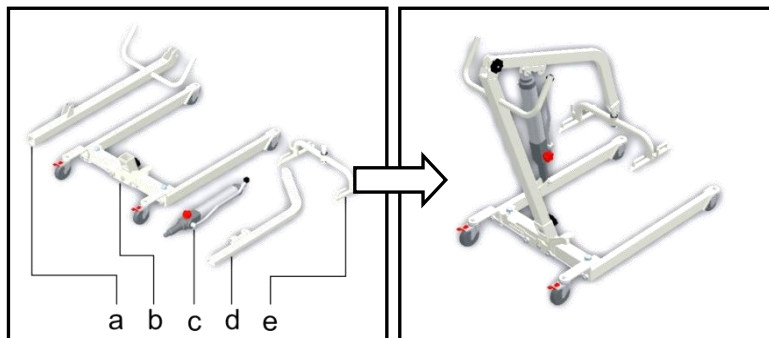

**B.** Attach the Mast to the Base and then the Boom to the Mast

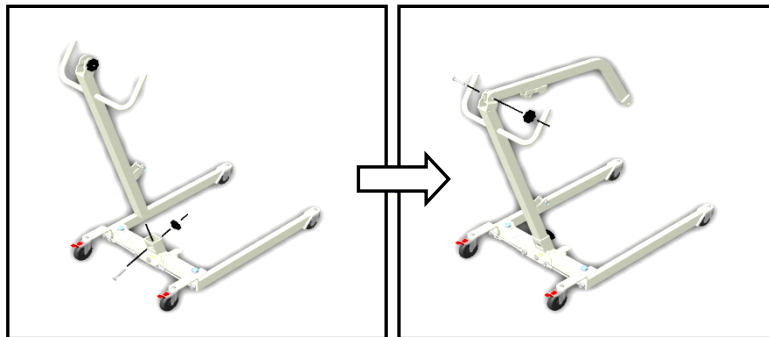

**C.** Attach the Hydraulic Pump and then Spreader Bar

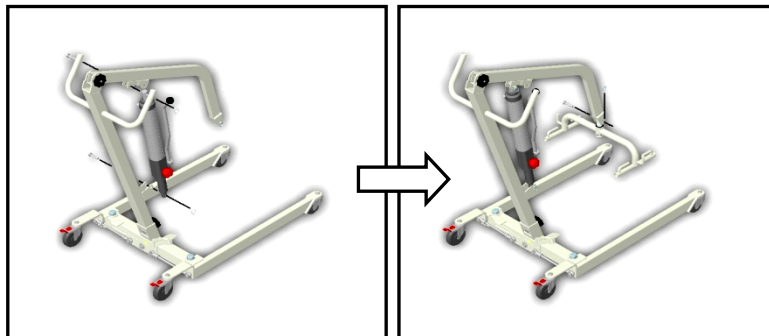



## ASSEMBLY INSTRUCTIONS

 **WARNING!** DO NOT ATTEMPT TO REMOVE THE LIFT FROM THE BOX WITHOUT ASSISTANCE. THE LIFT IS APPROXIMATELY 75LBS. AVOID INJURY!

Instructions for the assembly of both PL400H and PL400EL are the same except where noted. Assemble the patient lift in accordance with the following instructions:

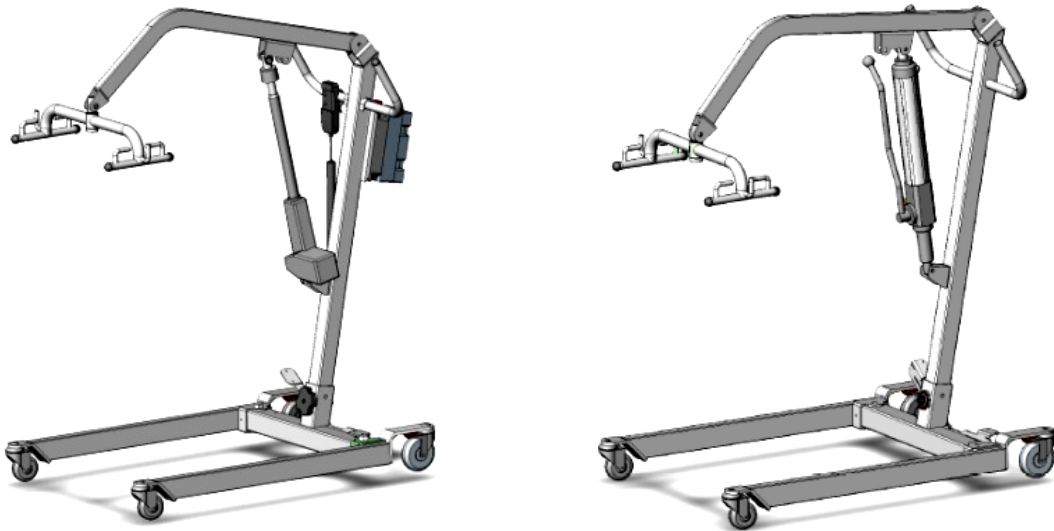

**STEP 1** Install the Mast into the square sleeve located at the rear and center of the Base and tighten the black plastic hand nut by hand.

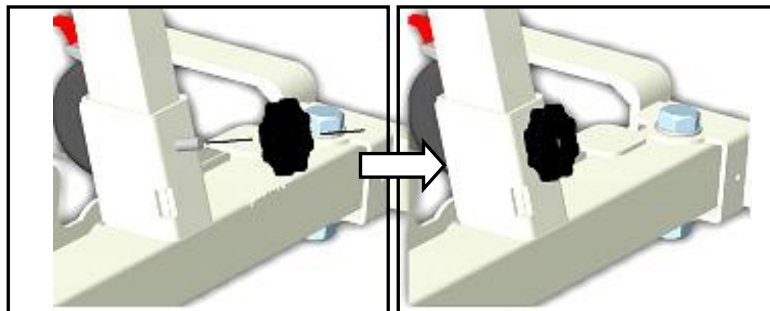

Carriage bolt head should slide into the **SQUARE** slot

**STEP 2** Install the boom between the brackets at the top of the Mast. Fasten with hex bolt, washer and black plastic hand nut.

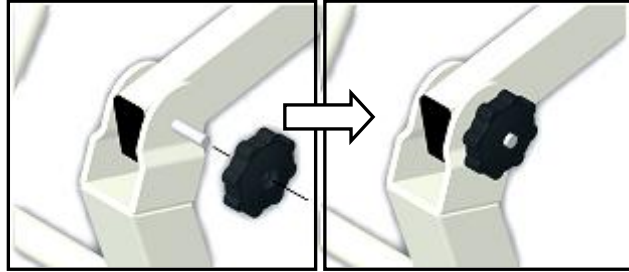

*Hex Bolt head goes on the side with the small lock screw pre-installed.*

**STEP 3** Install spreader at the end of the Boom and secure it in place with steel pin and key ring.

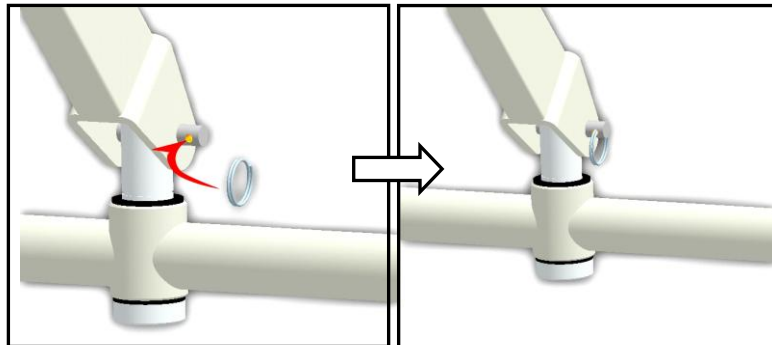

*Secure Spreader Bar to Boom with steel pin and key ring*

The BestLift PL400H Series of patient lifts comes in either the manual hydraulic operation PL400H or the PL400EL battery powered operation. If you have purchased the PL400H, you can upgrade to a battery powered lift by simply contacting your dealer or Bestcare to order the Electric Upgrade Kit.

The BestLift patient lift is ready to use as soon as the Hydraulic Pump or Electric Actuator is installed and the connections between the Base & Mast, Mast & Boom, and Boom & Spreader bar are secured. No tools are necessary to assemble the lift and can be accomplished with the supplied hardware. If you have any questions contact your dealer or Bestcare.

**STEP 4** Installation of Hydraulic Pump or Electric Actuator

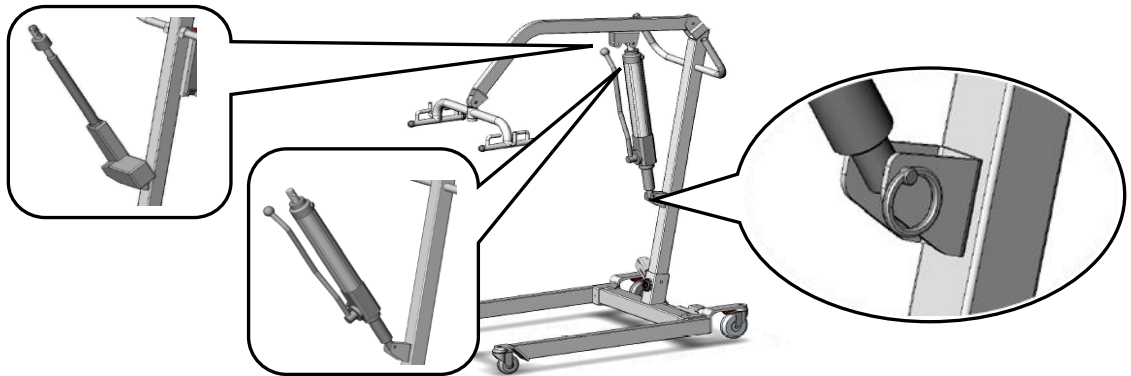

**A.** Attach bottom piston of either the Hydraulic Pump or Actuator by sliding it between the Mast brackets. Secure with steel pin and key ring.

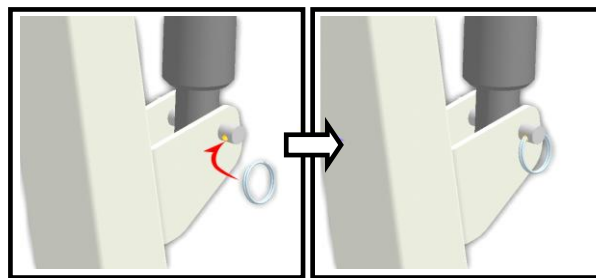

**i** Both Cylinder and Actuator attach to the **SAME** bottom bracket

**B.** Attach the top end of the of the Hydraulic pump or Actuator between the Boom bracket and secure with steel pin and key ring



*The top end of the Hydraulic Cylinder must be attached to the Boom bracket slots nearest the Mast. The Actuator must be attached to the Boom bracket farthest away from the Mast. This is indicated by the label next to the Boom bracket.*

i. Hydraulic Cylinder shall be installed at position: **a**

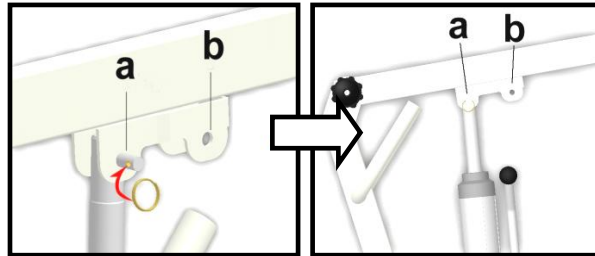

ii. The Electric Actuator shall be installed at position: **b**

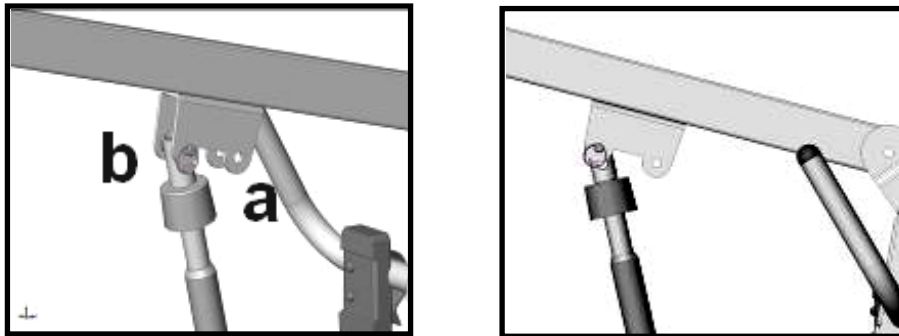

Incorrect installation may result in damage to the equipment or pose a safety risk.

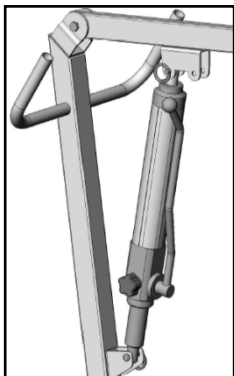

*The Genesis 400 Series Lift operates either in a Hydraulic or an Electric mode. The picture to the left shows a Hydraulic Cylinder and the one to the right an Electric Actuator*

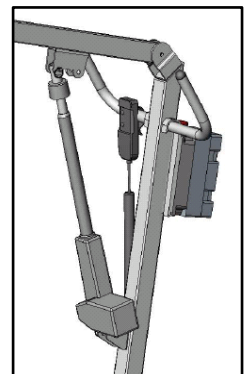

After installing the Hydraulic Cylinder, the assembly of the Hydraulic powered lift is complete. The following assembly instructions apply to PL400EL and Electric Upgrade Kit users only.

**STEP 5** Install the Control Box and Hand Control. These instructions apply to PL400EL and Electric Upgrade Kit owners **ONLY**.

- A.** Attach the Control Box hangers to the Control Box
- B.** Hang the control box by the hangers on the handlebars of the lift.
- C.** Insert the Hand Control plug into the second port from the top.
- D.** Insert the Actuator Plug into the third port from the top

**i** *The Actuator plug must be inserted all the way in until the Black O-ring is no longer visible or else the Actuator will not function. The first port is used for the Charger and the remaining ports are unused.*

## DIAGRAM OF CONTROL BOX

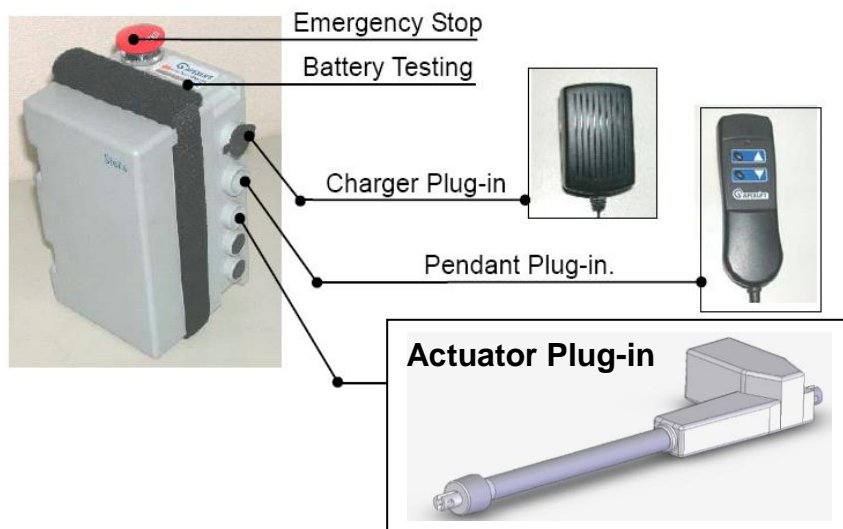

## MAINTENANCE & INSPECTION CHECKING LIST

The operator of the lift is to inspect the BestLift 400 Series Bestcare Lift before each use. Check all bolts for tightness. Make sure the base can be easily widened, and that all lift parts are in place. Make sure all casters turn freely, and that the caster brakes can be engaged. Make certain all necessary items (i.e. slings, wheel chairs, etc.) are accessible and ready for use. Check No Tool Hand Nuts also. At least once a month, the lift should be thoroughly inspected by a person qualified to recognize any signs of wear, and looseness of bolts or parts. Replace any worn parts immediately. To lubricate, place a drop of oil on the following points: Top of Mast, Spreader Hinge, and Caster Axles when the PL400H or PL400EL is assembled and every month thereafter.

### Checking The Battery

1. Check batteries by pressing the Battery Testing Button (blue circle with a battery sign) on the control box.
2. Batteries are fully charged when all lights on the Battery Indicator are "ON".
3. Charge batteries when Indicator shown only one "GREEN" light.
4. Do not use the lift when no "GREEN" light is shown. Charge the batteries immediately.
5. Replace batteries when frequent charging is needed.

### Know What The Battery Indicator Lights Are Telling You:

RED	AMBER	GREEN	GREEN	GREEN	NOTE
ON	ON	ON	ON	ON	FULLY CHARGED
ON	ON	ON	OFF	OFF	NEED CHARGE
ON	ON / OFF	OFF	OFF	OFF	CHARGE IMMEDIATELY. DON'T USE THE LIFT
OFF	OFF	OFF	OFF	OFF	BAD BATTERIES OR BAD CONNECTION

## Warning Buzzers

The control box has a buzzer that provides you with information on the status of the batteries and the lift. To stop the buzzer, push down the RESET button or press the Battery Indicator.

BUZZER TYPE	INDICATION	NOTE
2 beeps/sec	Low Battery (red/amber lights on)	Charge batteries immediately.
3 beeps/sec	Low Battery (red light on)	Charge batteries immediately.
6 beeps/sec	Very Low Battery (no light on)	Charge batteries immediately.
3 beeps every other second	Bad Battery (no light on)	Replace batteries.
3 long beeps	Overloaded. Batteries are charged but lift does not lift.	Exceeded maximum load capacity.

## Charging The Batteries

1. Ensure the power is switched "ON" (the red "RESET" button should be up).
2. Insert charging plug into charging port on the control box.
3. Plug charger to power supply.
4. All lights of battery indicator should be "ON" while charging.
5. It takes approximately 2-3 hours to fully charge the batteries from one green light.
6. It takes approximately 7-9 hours to fully charge the batteries from the red light.
7. Do not leave the batteries on charging for an extensive period of time. This will shorten the life of the batteries.
8. Do not let the batteries run down to the last red light. This might shorten the life of the batteries or damage the batteries.
9. Unplug the charger first before using the lift.

## Important Notes On Charging

- Push lift to charging location and charge the batteries with the charger provided. Avoid unplug hand control and motor from control box. Frequent plug/unplug of the hand control and motor into/from the control

box may damage the control box.

- Do not charge batteries over 12 hours.

## OPERATING INSTRUCTIONS

**NOTE:** Turn the lift “ON” by turning the red “RESET” button clockwise. Turn the lift “OFF” by pressing down the “RESET” button.

## MAINTENANCE SCHEDULE

Item	In the Beginning	Monthly	Every 3 months
<b>Boom &amp; Spreader Bar:</b> Check connections between 1) Boom and Spreader Bar and 2) Boom and Mast for improper connection, looseness, or wear. 3) Check the Boom for bending and deflection.	●  ●	●  ●	
<b>Mast:</b> 4) Check the Mast for bending or deflection. 5) Check the steering bar for damage or loose screws.	●  ●	●  ●	
<b>Base &amp; Foot Peddle:</b> 6) Check bolts and nuts for looseness. 7) Check casters and axle bolts for tightness. 8) Check rubber parts on the casters for deflection. 9) Apply grease to caster ball bearings if needed.	● ● ●	● ●	● ●
<b>Cleaning:</b> 10) As needed.			●
<b>Actuator &amp; Control Box:</b> 11) Make sure the control box is firmly affixed to the mast. 12) Make sure the pins are firmly affixed the actuator to the Boom and the Mast. 13) Make sure the connecting cable of the actuator and the control box is not loose. 14) Make sure the Battery Indicator has least 2 green LED lights illuminated prior to use.	● ● ● ●	● ● ● ●	
<b>Slings &amp; Sling Hardware:</b> 15) Check sling for wear. 16) Check sling hardware every time before use.	● ●	● ●	



## Transfer From Bed

Roll user onto the opposite side and position him/her on the flat section of the sling. This will allow you to unroll the remainder of the sling from the other side of the user.

Once the sling has been positioned centrally, feed the leg sections under the thighs and draw them up between the thighs.

Should Raise and Lower the head of the bed if this function is available.

Move the lift slowly towards the user and position the spreader bar over the user's/patient's chest.

Attach Loops to Spreader Bar: Notice Loops on sling attach to Spreader Bar Hooks **A & C** and **B & D** as illustrated below. The Bottom two Loops **E** and **F** are connected to opposite Hooks on the Spreader Bar after passing one Loop through the other.

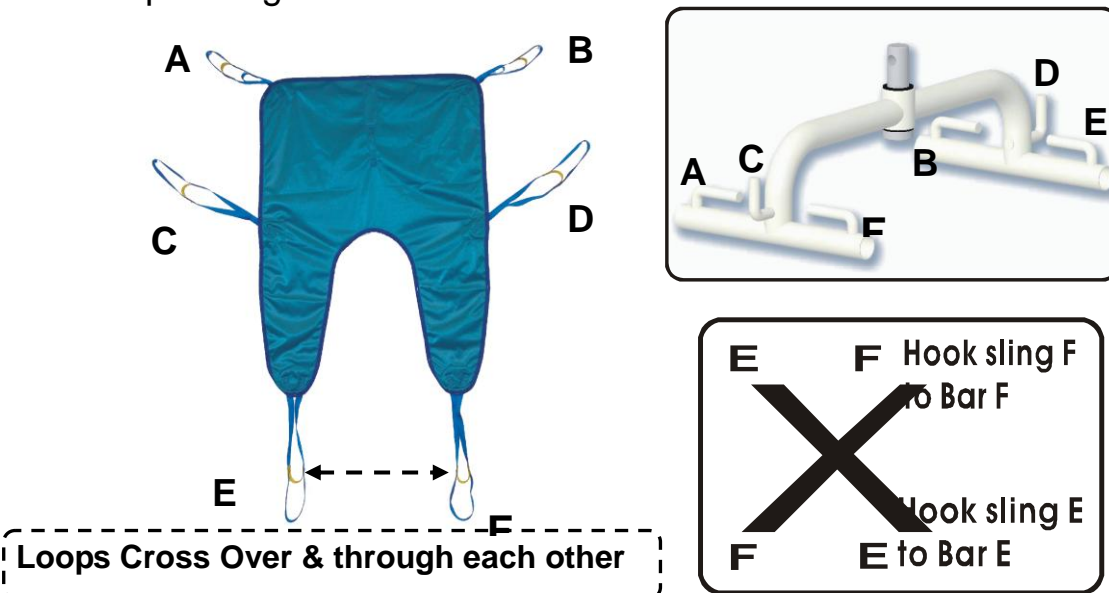

**Note:** Reverse the above procedures when returning the user/patient to bed

- Lift the user above the bed by using the Hand Control or Hydraulic pump handle. (Wheels unlocked & base spread wide while lifting, foot pedals control base width)
- Pull lift away from bed. Position user over the wheelchair or chair then lower the patient onto the surface. (Widen base for access to wheelchair)

**Note:** Reverse the above procedures when returning the user/patient to bed. There must always be at least one caregiver present when lift is in use.

## **Transfer From Wheelchair**

- Grasp the sling at each corner of the "U" shape of the commode aperture. (Sani Sling)
- The sling should be fitted with the handle on the back section facing outward.
- Help the user lean forward slightly, then slide the sling down between the chair and the user's back.
- Position the commode aperture where the buttocks meet the seat.
- Position the sling equally around both sides of the body.
- Draw the leg sections to the front along the length of the user's thigh.
- Check the sling's central positioning by comparing the lengths of the leg sections when they are drawn forward.
- Reposition the sling if the leg sections are not equal in length.
- Feed the leg sections under the thighs.
- From between the legs, gently pull the leg section up the inner thigh.
- Feed as much material as possible under and between the thighs. Ensure the leg sections are positioned midway under the thighs to provide good support and greater comfort.
- Move the lift slowly towards the user and position the spreader bar over the user's chest.
- Attach Loop a of sling to Hook A on Spreader Bar; attach Loop B to Hook B; attach Loop C to Hook C; attach Loop D to Hook D. (See example on page 15)
- Lift patient above the wheelchair by using the Hand Control.
- Pull lift away from wheelchair. Position patient over bed and lower patient onto it. Always close base before transferring patient. Foot pedals control base width.

**Note: Reverse the above procedures when returning the user/patient to a wheelchair.**

## **Troubleshooting Guide**

The following list of encountered problems and solutions will assist you in determining what may be causing your Bestcare lift not to function as designed. If you have a problem occurring that is not listed below please contact your dealer or Bestcare technical support for help. Do not attempt to repair components or parts on your lift as this may invalidate your warranty or cause further problems that may result in patient injury. Stop using your lift immediately if it is not functioning correctly or any warning beeps are heard.

### ***I need to re-charge my batteries often or they fail to hold a charge when I charge them***

- Replace the 2 internal batteries as they are at the end of their life cycle
- Batteries should be changed every 18-24 months depending on usage

### ***When I plug my charger into the control box I see no lights on the battery indicator***

- Check to make sure the red re-set button is in the up position
- Check to make sure the charger is firmly in the control box and plugged into a wall socket
- Replace your charger as it is at the end of its life cycle
- If your charger is transmitting current then you need to replace your PCB board in the control box

### ***My actuator makes a clicking sound when I attempt to use my lift***

- Check to make sure the actuator plug is pushed into the control box so the O Ring is not visible
- Your actuator needs to be replaced as it is at the end of its life cycle
- Your PCB board in the control box may be malfunctioning

### ***The actuator will either go up or down but not both***

- Replace your hand control as it is at the end of its life cycle
- Your PCB board in the control box may be malfunctioning

### ***There is a grinding sound inside the actuator when lifting***

- Replace your actuator as the internal gears are stripped

### ***The actuator stops and starts while lifting or lowering***

- Replace your batteries as they are at the end of their life cycle

***My lift will not operate even though it shows the batteries are charged***

- Disconnect your charger from the control box as the lift will not work when the charger is attached
- Check to make sure the hand control is properly inserted to control box
- Check to make sure your actuator is properly connected to the control box
- Your hand control needs to be replaced as it is at the end of its life cycle

***My lift will not operate and battery indicator has no lights illuminated***

- Check to make sure the red re-set button is in the up position
- The internal batteries may not be connected together properly with the connection wires
- Batteries will no longer hold a charge and must be replaced
- Your PCB board is damaged and must be replaced

***When lifting I hear 3 long beeps from the control box***

- You are attempting to lift someone heavier than the safe working load
- Stop the lift and lower safely to bed or chair immediately

***When lifting I hear short beeping sounds from the control box***

- Charge the batteries
- Replace the batteries if they fail to hold a charge

## Hydraulic Pump Troubleshooting

***Hydraulic Pump won't lift Boom:***

Turn Release Knob counter-clockwise fully until it stops. Pump handle 5 times. Tighten the valve. The Hydraulic pump should now rise or lower.

***Air is trapped in Hydraulic Cylinder:***

Turn Release Bolt on top counter-clockwise.  
Let pump return to the lowest position.  
Tighten Release Bolt.



If there is any problem you could not solve, please contact the dealer for assistance.

## EMERGENCY LOWERING MECHANISM

In case of lift failure while using the BestLift 400EL, please follow the procedures below to safely lower the user.

The Emergency Lowering Device is located at the top of the actuator shaft. It is intended for use if the actuator fails to operate while a patient is suspended. The device consisting of a plastic collar ring should be turned clock-wise continually until the patient has been lowered.

Contact your dealer immediately if standard troubleshooting techniques do not correct the failure. Do not attempt to lift until all failure issues have been safely resolved.

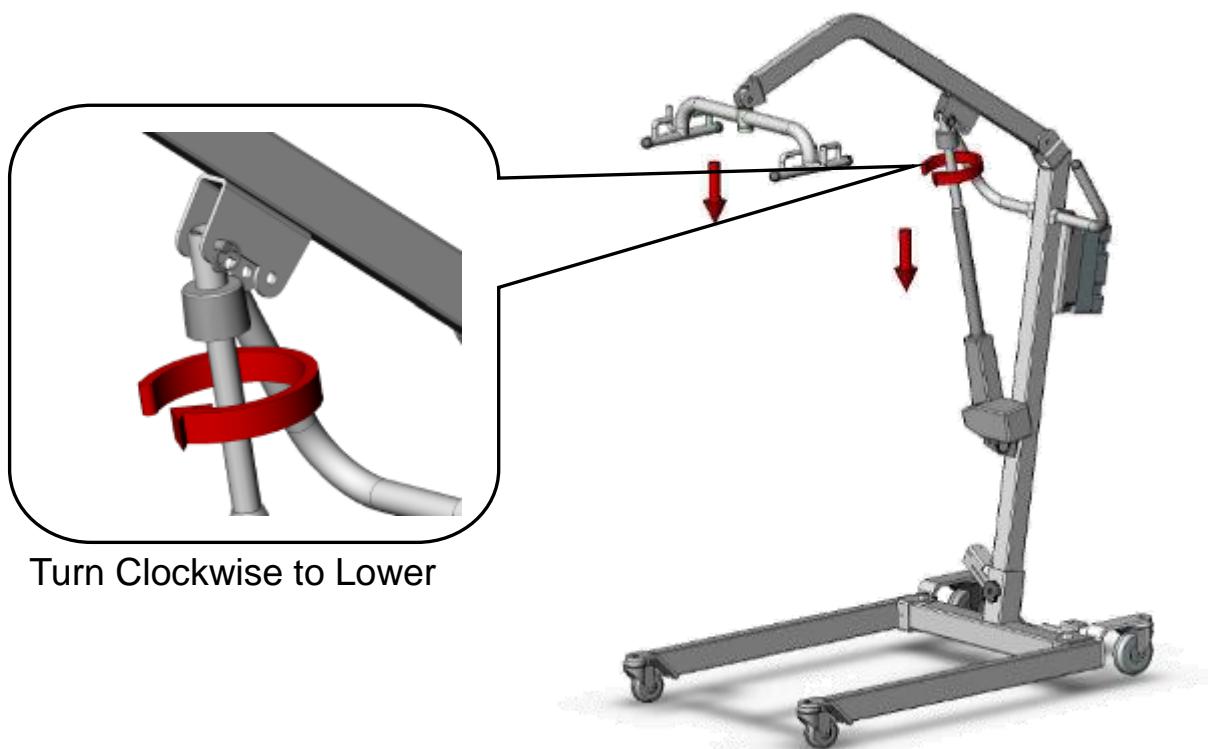

Turn Clockwise to Lower

### **Note :**

*THE EMERGENCY LOWERING DEVICE IS INTENDED FOR USE DURING LIFT FAILURE. THIS DEVICE WILL ALLOW LOWERING OF PATIENTS ONLY. PLEASE CONTACT YOUR DEALER IMMEDIATELY IN CASE OF FAILURE.*

***Thank you for choosing the BestLift 400***