

SWIM LIFT MODEL - FREEDOM

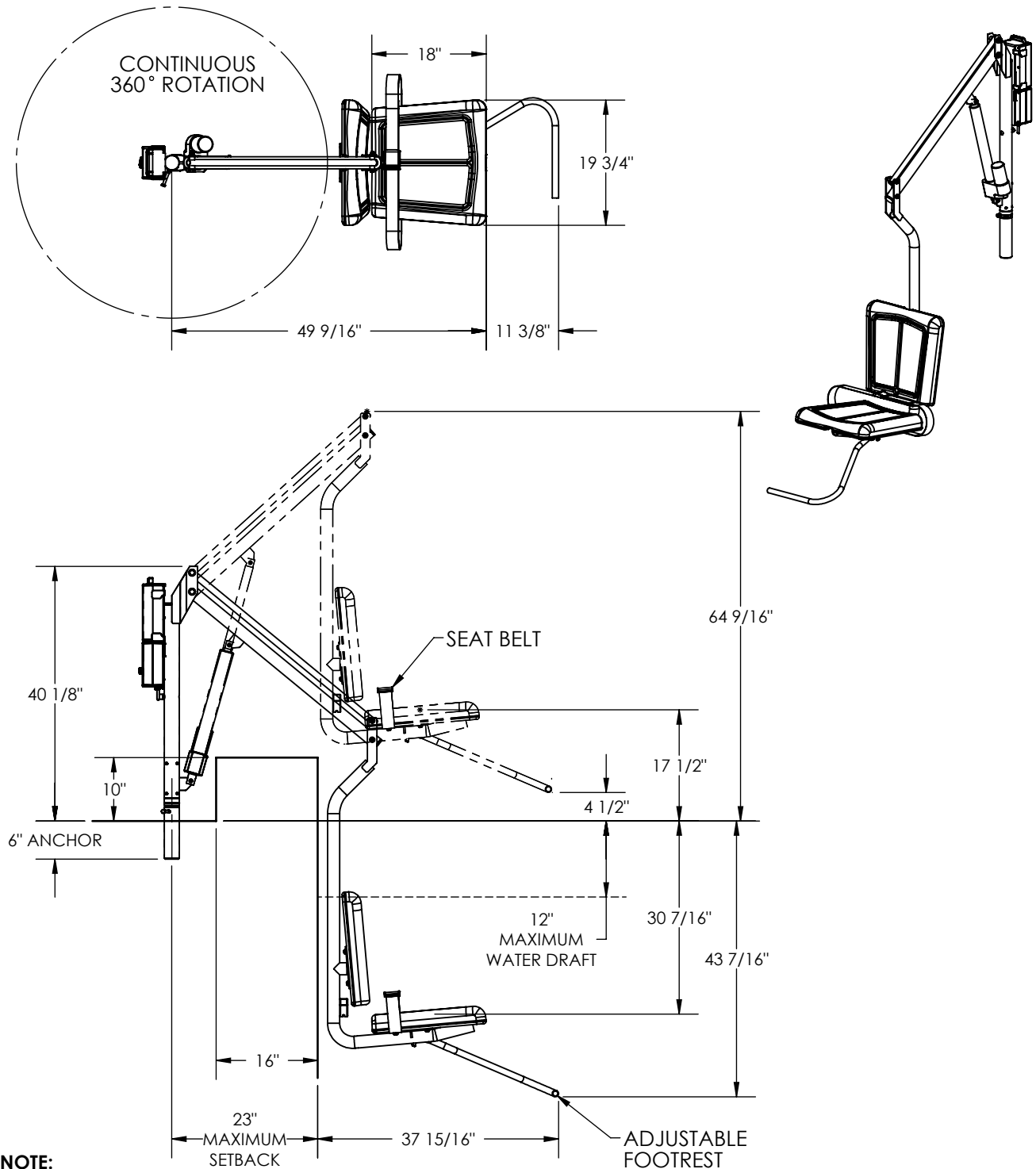

NOTE:

1 DIMENSIONS VARY WITH SPECIFIC APPLICATIONS.
 SPECIFICATIONS ARE NOMINAL AND ARE SUBJECT TO CHANGE.
 PLEASE CONTACT SPECTUM PRODUCTS FOR CUSTOM APPLICATIONS.

SPECTRUM
Products

7100 Spectrum Lane
 Missoula, Montana 59808
 406.542.9781 * 800.791.8056
 Fax: 406.542.1158
 www.spectrumproducts.com

ENGINEERING DATA

PRODUCT:	FREEDOM BP350
PRODUCT #:	57961
REVISION:	A
MATERIAL:	304 SERIES STAINLESS STEEL