

Instructions

GATEWAY® 3G Solid Surface Portable Ramp

Portable ramp for temporary or semi-permanent use. Available with or without handrails.

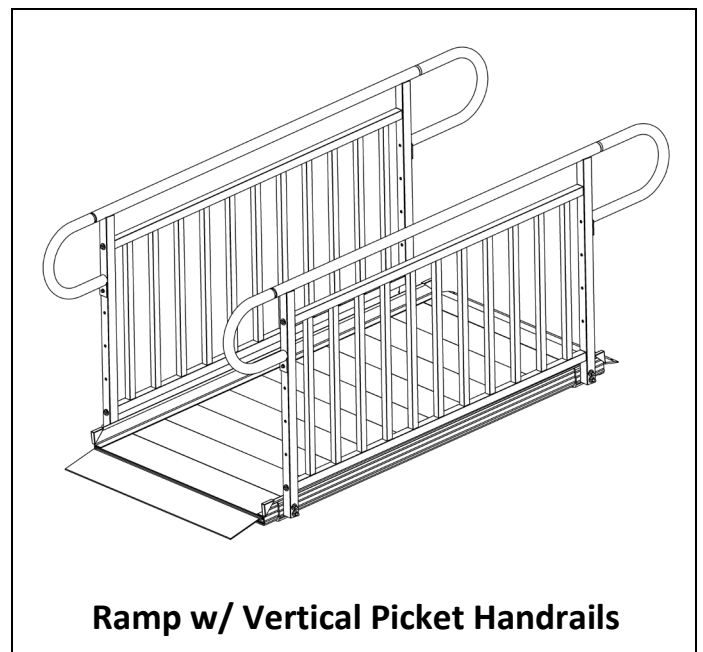
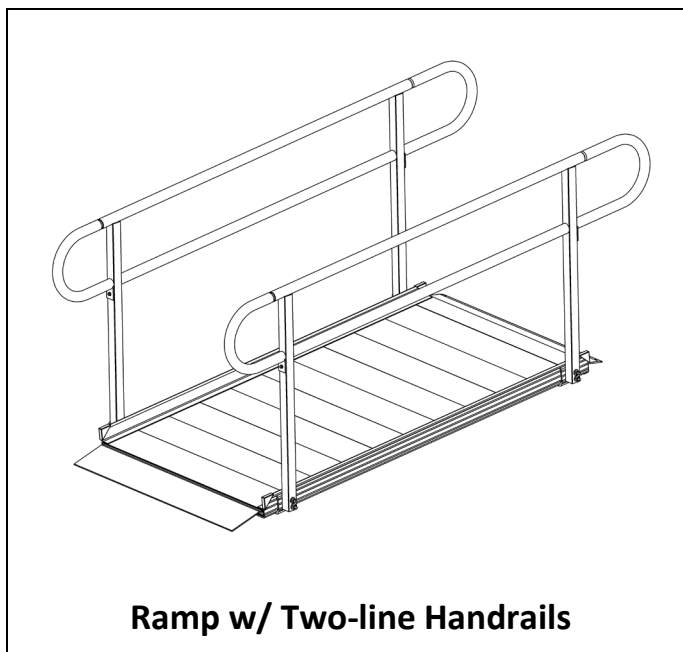
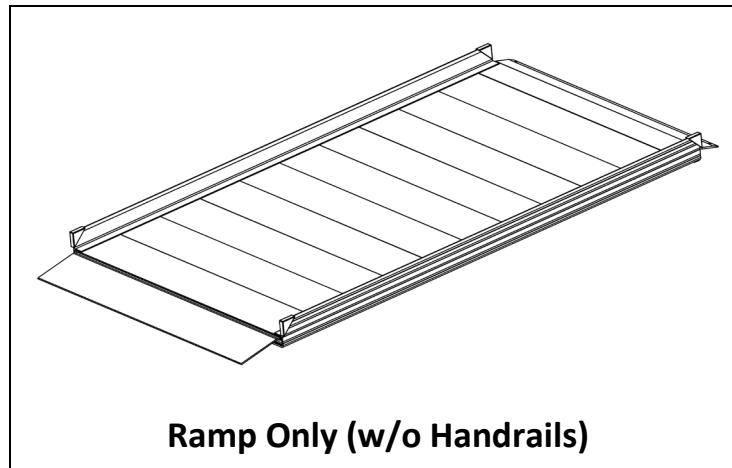

INTRODUCTION

The GATEWAY® 3G Solid Surface Portable Ramp is available in 3 configurations: ramp without handrails, ramp with two-line handrails, and ramp with vertical picket handrails (if walking on the ramp, handrails are required). This portable ramp is ideal for either temporary or semi-permanent applications and is designed for the rigors of repeated, everyday use. Throughout these instructions, the GATEWAY 3G Solid Surface Portable Ramp is also referred to as 'ramp' and includes the ramp, handrails (if purchased), and any/all components and hardware that are intended to be assembled on the ramp.

SYMBOLS

- ⚠ The **WARNING** symbol indicates a potentially hazardous condition/situation. The warnings throughout this document, and on your equipment, if any, are for the protection of people and property. Failure to abide by warnings will result in a waiver of all liabilities, loss of your warranty, and could result in equipment damage and or failure, property damage, risk of serious bodily injury, and or death to operators, riders, and those nearby. The symbol may appear in various colors and in conjunction with other symbols.
- 👉 The **NOTE** symbol indicates important information. Failure to obey all notes could result in improper operation, less-than-optimum equipment performance, and at the sole discretion of the equipment manufacturer, may void your warranty. The symbol may appear in various colors and in conjunction with other symbols.

WARNINGS

- ⚠ Maximum weight capacity is 1,000 lbs.; never exceed weight capacity.
- ⚠ Prior to assembly and use, read and follow all instructions, warnings, and labels. Following all instructions and obeying all warnings before and during use is necessary for safe operation. For additional information or to obtain replacement copies of instructions or labels, call 1-800-451-1903.
- ⚠ For people and mobility equipment only; not for commercial use.
- ⚠ Consult local building codes regarding securing the ramp for wind loads.
- ⚠ Before use with mobility equipment, refer to your mobility equipment's owner guide for acceptable ramp usage, including proper slope/incline, chair direction, etc.; never exceed its recommendations.
- ⚠ Only use the ramp with a qualified helper.
- ⚠ Always use a lap belt if using the ramp with mobility equipment.
- ⚠ If walking on the ramp, handrails are required and must be installed.
- ⚠ Before each use, check the ramp for worn, loose, or damaged parts. If you find any of these conditions, do not use the ramp and contact your dealer for service or repairs; failure to do so may result in serious injury.
- ⚠ Do not use the ramp if it is damaged or unstable.
- ⚠ Do not tamper with, attempt to repair, or modify any portion of the ramp.
- ⚠ Ensure that the landings the ramp will be placed on are substantial and of sound construction.
- ⚠ Use only if the secure, unobstructed, level landings can support, at minimum, the same weight capacity as the ramp (1,000 lbs.).
- ⚠ Ensure that the surface area of the top lip transition plate fully overlaps a secure, unobstructed, level landing enough to safely install provided clevis pins or other non-provided anchoring hardware, and rests firmly against the upper landing. If a secure, unobstructed, level landing cannot be attained, do not use the ramp.
- ⚠ Ensure that the ramp is securely anchored before each use.
- ⚠ Use only if sufficient maneuvering room is available at both ends of the ramp to assure safe travel when entering and exiting the ramp.
- ⚠ The ramp surface may be slippery in wet conditions; use caution as traction may be reduced.
- ⚠ Do not use the ramp if its surface is covered with ice, snow, dirt, leaves, or other debris. Remove all accumulations and sweep the surface clean before use.
- ⚠ Do not run, jump, or play on or around the ramp, including climbing on or between the handrails.
- ⚠ Do not use any part of the ramp to support planters, lights, decorations, etc.
- ⚠ Improper use of the ramp could result in serious injury.
- ⚠ Always exercise caution when handling, installing, and or using the ramp.
- ⚠ Aluminum conducts electricity. Do not use or handle the ramp around live wiring or during electrical storms.

TOOLS AND HARDWARE TYPICALLY REQUIRED







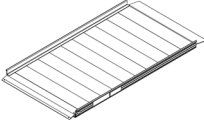
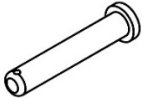

- 1/2" SOCKET OR 1/2" WRENCH
- 1/4" NUT DRIVER OR SOCKET
- POWER DRILL
- 1/4" MASONRY DRILL BIT (IF ANCHORING INTO CONCRETE)
- SEMI-PERMANENT ANCHORING HARDWARE & TOOLS (SEE 'SETUP AND USE' SECTION)
- CONSTRUCTION ADHESIVE

1. **GETTING STARTED**

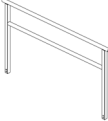

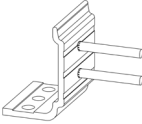

- 1.1 Read this instruction manual in its entirety before use and follow all instructions before and during use.
- 1.2 Before use with mobility equipment, refer to your mobility equipment's owner guide for acceptable ramp usage, including proper slope/incline, chair direction, etc.; never exceed its recommendations.
- 1.3 Before each use, check the ramp for worn, loose, or damaged parts. If you find any of these conditions, do not use the ramp.
- 1.4 Confirm that all package contents are present. Open the shipping box(es) and inspect for damaged or missing parts. If damaged or missing parts are noted, do not use the ramp.

2. **PACKAGE CONTENTS**

Contents may vary depending on options purchased.

QTY	DESCRIPTION	IMAGE (NOT SHOWN TO ACTUAL SIZE)
1	EZ-ACCESS® GATEWAY® 3G SOLID SURFACE PORTABLE RAMP	
2	CLEVIS PIN	
4	CORNER PROTECTIVE CAP	
2	HANDRAIL: TWO-LINE <i>(If two-line handrails were purchased)</i>	
2	HANDRAIL: VERTICAL PICKETS <i>(If vertical picket handrails were purchased)</i>	
4	HANDRAIL END BRACKET <i>(If handrails were purchased)</i>	
4	HEX BOLT 5/16" - 18 X 1-1/2" Long <i>(If handrails were purchased)</i>	
12	FLAT WASHER 5/16" x 7/8" OD <i>(If handrails were purchased)</i>	
8	HEX NUT 5/16" - 18 <i>(If handrails were purchased)</i>	
2	UPPER END LOOP Shown with O-ring and Attachment Screw <i>(If handrails were purchased)</i>	

3. **PACKAGE CONTENTS, CONT'D.**

2	LOWER END LOOP Shown with O-ring and Attachment Screw <i>(If handrails were purchased)</i>	
4	SCREW 1/4" Self-drilling, Self-tapping Hex Washer Head <i>(If handrails were purchased)</i>	
4	O-ring <i>(If handrails were purchased)</i>	
1	INSTRUCTIONS	

4. **AVAILABLE RAMP LENGTHS AND STYLES**

- 4.1 The ramp is available in 3-, 4-, 5-, 6-, 7-, 8-, 9-, and 10-ft. lengths and comes with a self-adjusting lower transition plate and a fixed top lip transition plate.
- 👉 Ramp lengths of 3-ft. through 8-ft. have 2-in. curbs; the 9-ft. and 10-ft. lengths have 4-in. curbs.
- 4.2 Shown below is the 6-ft. ramp without handrails (FIG. 1), the 6-ft. ramp with two-line handrails (FIG. 2), and the 6-ft. ramp with vertical picket handrails (FIG. 3).

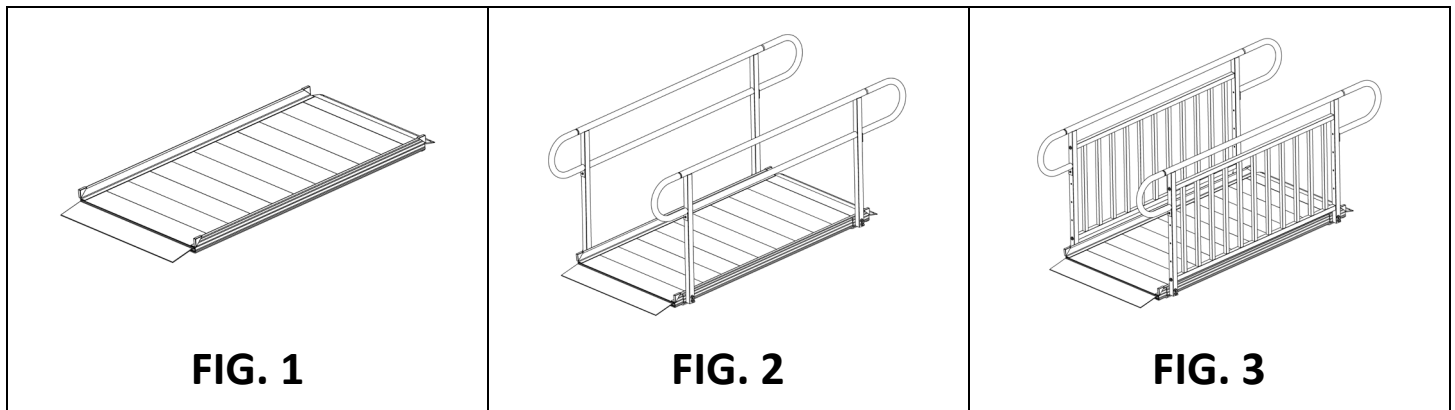

5. **CARE AND MAINTENANCE**

- 5.1 Before each use, check the ramp for worn or damaged parts. If you find any of these conditions, do not use the ramp.
- ⚠ Do not tamper with, attempt to repair, or modify any portion of the ramp.
- 5.2 Before each use, tighten any loose fasteners.
- 5.3 Keep the ramp surface clear of ice, snow, dirt, leaves, and other debris. For ice and or snow, remove all accumulations and sweep surface clean. For dirt, leaves, and other debris, sweep surface or wash with a soft bristle brush and non-alkaline detergent, rinse well.
- ⚠ The ramp surface may be slippery in wet conditions. Use caution if surface is wet as traction may be reduced.
- 5.4 Store the ramp in a cool, dry place when not in use.

6. INSTALLING HANDRAILS

- 6.1 If you did not purchase the ramp with handrails, skip ahead to the 'SETUP AND USE' section.
 - ▲ If walking on the ramp, handrails are required and must be installed.
 - 👉 Regardless of the handrail style, attaching handrails to the ramp follows the same process.
- 6.2 Place the walking surface side of the ramp face down, onto cardboard or lawn so that the ramp is not damaged (scratched or dented).
- 6.3 Install one end bracket ('bracket') on each corner of the ramp (FIG. 4).
 - 6.3.1 Slide the upper lip of the bracket into the groove in the ramp side rail.
 - 6.3.2 Using the holes shown (FIG. 4), align the innermost hole of the end bracket over the threaded insert on the ramp, then secure the bracket to the ramp by inserting a 5/16"-18 x 1-1/2" bolt and washer. Tighten securely with 1/2" socket or wrench.
- 6.4 After each bracket (4 total) is installed and secured, turn the ramp to its upright position, being careful not to damage the studs in the brackets.

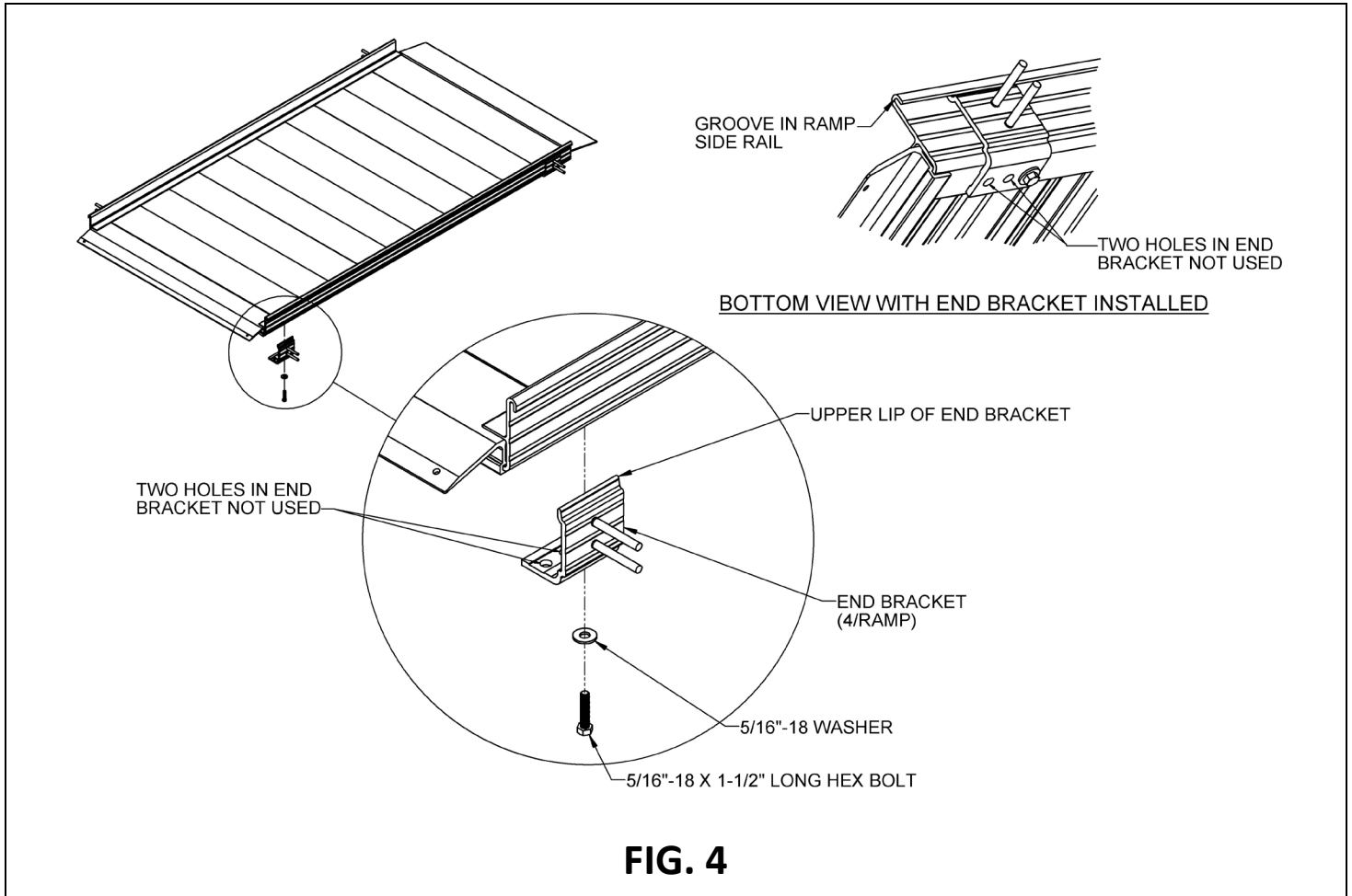

6.5 Ramp handrail posts each have two holes that correspond with the studs on the brackets. Place the side with the holes onto the bracket studs (FIG. 5).

👉 Handrails are interchangeable from side to side.

6.5.1 Attach using (2 ea.) 5/16" washers and 5/16"-18 nuts per handrail post. Tighten securely with 1/2" socket or wrench.

6.5.2 Repeat for the second handrail on the opposite side of the ramp.

⚠️ One handrail is required on each side of the ramp.

6.5.3 If end bracket studs do not align with holes in handrail posts, there are a couple of areas to confirm:

- ① Ensure that the end bracket is installed into the proper threaded insert (see FIG. 4 for proper installation location).
- ② Ensure the orientation of the handrail section is correct. If necessary, flip the handrail section 180-degrees so that 'END #1' is flipped to the 'END #2' position (FIG. 5).

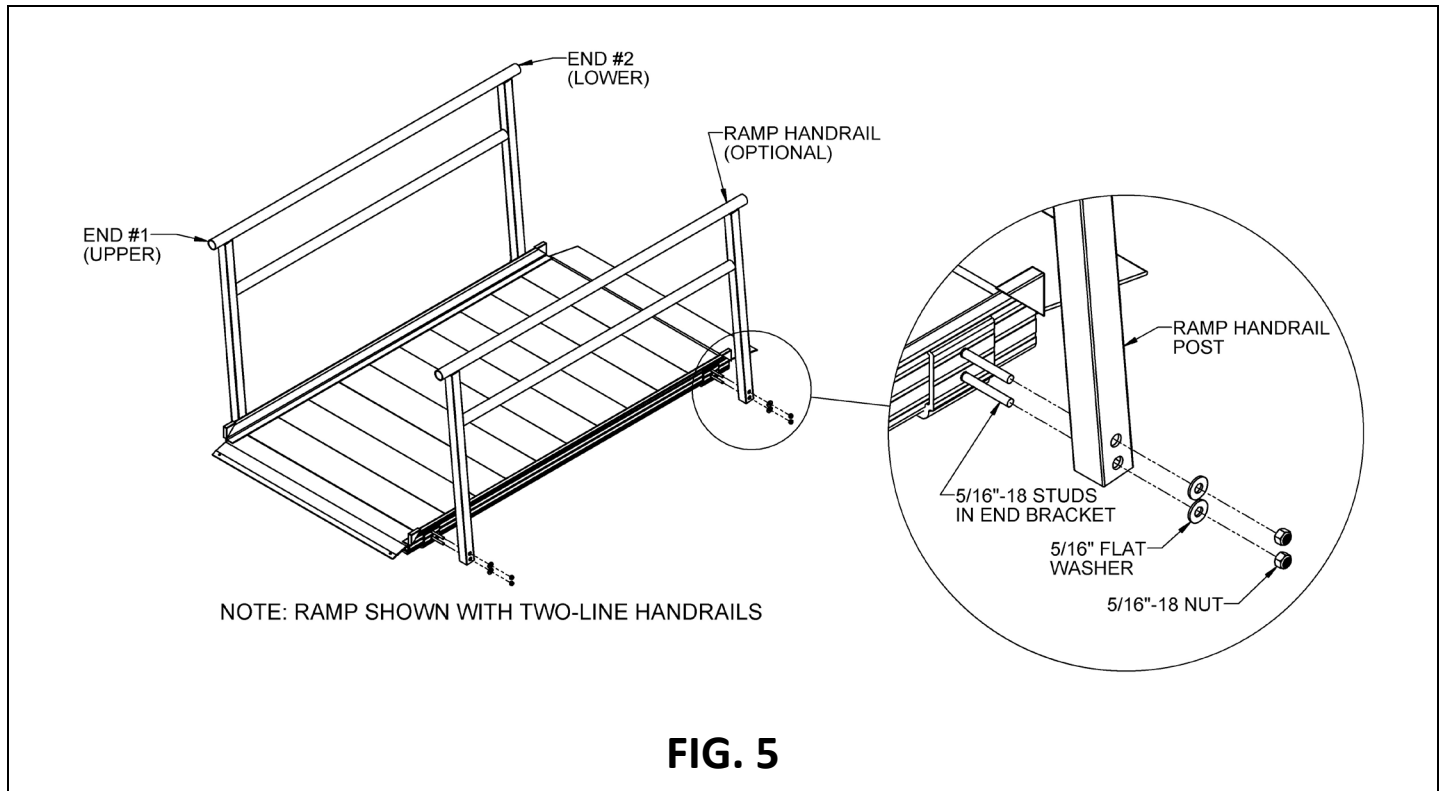

7. **INSTALLING HANDRAIL END LOOPS**

7.1 Ramps ordered with optional handrails – two-line or vertical pickets – feature end loops which are added at both the upper and lower ends of each handrail (FIG. 6).

7.1.1 FIG. 6 shows loops installed on a two-line handrail. However, the installation process is the same for both handrail styles.

7.1.2 There are two loops, an upper and a lower. The upper loop is the larger of the two and is used on the top of a ramp handrail; the lower loop is slightly smaller and is used on the bottom of the ramp handrail. Upper and lower loops are not interchangeable but are installed in the same manner.

7.1.3 FIG. 7 (upper loop) and FIG. 8 (lower loop) show the difference between loops.

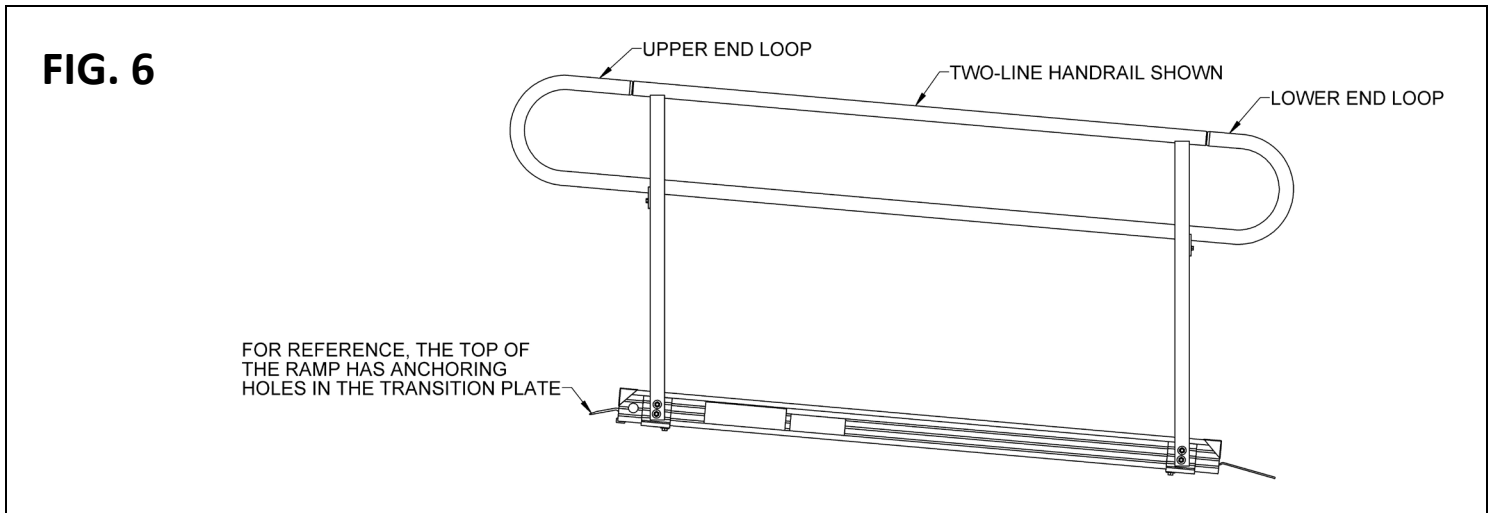

FIG. 7

UPPER END LOOP IDENTIFICATION:

- THE ATTACHMENT PLATE ON THE **UPPER** END LOOP ANGLES IN, TOWARD THE LOOP BEND.
- ALSO, THE DISTANCE BETWEEN THE TUBE BEND AND THE END LOOP ATTACHMENT PLATE IS LONGER THAN ON THE LOWER END LOOP.

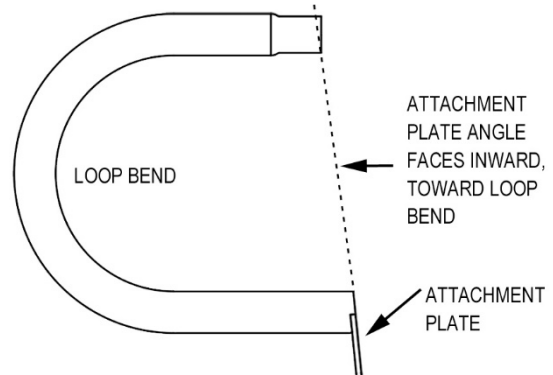
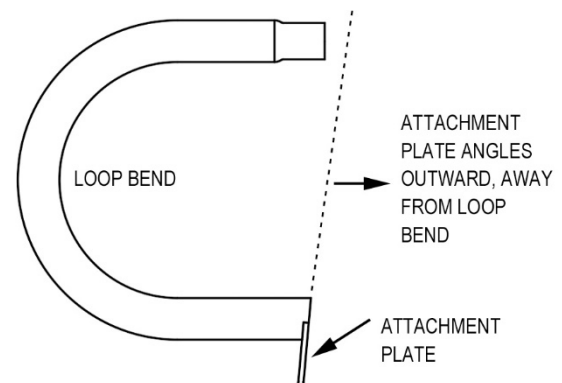

FIG. 8

LOWER END LOOP IDENTIFICATION:

- THE ATTACHMENT PLATE ON THE **LOWER** END LOOP ANGLES OUT, AWAY FROM THE LOOP BEND.
- ALSO, THE DISTANCE BETWEEN THE TUBE BEND AND THE ATTACHMENT PLATE IS SHORTER THAN ON THE UPPER END LOOP



- 7.1.4 Place one O-ring over the swaged portion of the end loop, then push until it rests against the loop shoulder (FIG. 9).
- 7.1.5 Repeat for all end loops.

FIG. 9

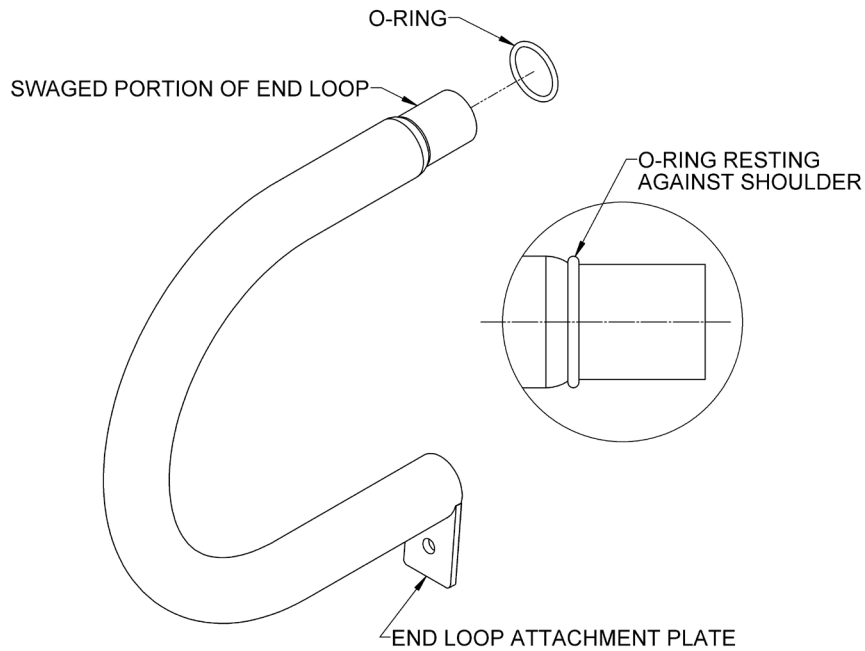

- 7.1.6 Using a 1/4" driver of choice, install one 1/4" self-drilling, self-tapping hex washer head screw through the hole in the end loop attachment plate and into the handrail post (FIG. 10).
 - 7.1.7 Repeat for all end loops, then tighten securely.
- 👉 If the end loop being installed does not fit correctly, ensure you have the correct loop for the location. Refer to FIGs. 7 and 8 for upper/lower end loop identification.

FIG. 10

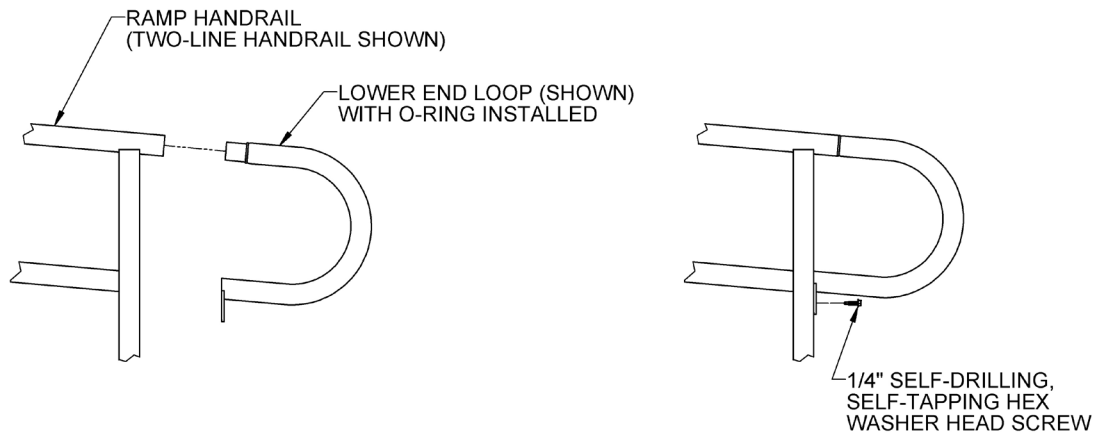

8. SET UP AND USE

- 8.1 Place the ramp's top lip transition plate (identifiable by its two pre-drilled holes) onto the upper landing. Ensure that the surface area of the top lip transition plate fully overlaps a secure, unobstructed, level landing enough to safely install provided clevis pins or other non-provided anchoring hardware, and rests firmly against the upper landing (FIG. 11).
- 8.2 Securely anchor the ramp to the upper landing.
 - ⚠ Ensure that the ramp is securely anchored before each use.
 - 8.1.1 TEMPORARY: To attach temporarily using the provided clevis pins, position the ramp securely and use the holes in the top lip transition plate as a template to drill corresponding 1/4" holes into the upper landing (ensure drilled holes are deep enough to fully seat each clevis pin). Fully insert a clevis pin (FIGs. 11 and 12) through the pre-drilled holes in the top lip transition plate and into the corresponding drilled holes in the landing.
 - 8.1.2 SEMI-PERMANENT: To attach semi-permanently using non-provided anchoring hardware, position the ramp securely and use the holes in the top lip transition plate as a template to identify anchor locations. Install non-provided anchoring hardware flush with the surface of the top lip transition plate and ensure that it does not create a hazard.
 - 🚫 Semi-permanent anchoring hardware is not provided.
 - ⚠ When using non-provided anchoring hardware, follow hardware manufacturer's installation instructions. Ensure the hardware is of sufficient type and size to prevent ramp slippage or undo movement.
- 8.3 Install one corner protective cap onto the end (4 total) of each side rail (FIG. 12). Use construction adhesive to bond the caps to the ramp.

FIG. 11

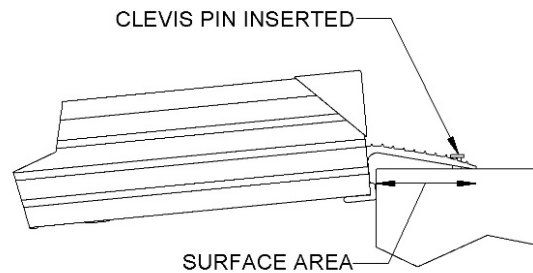
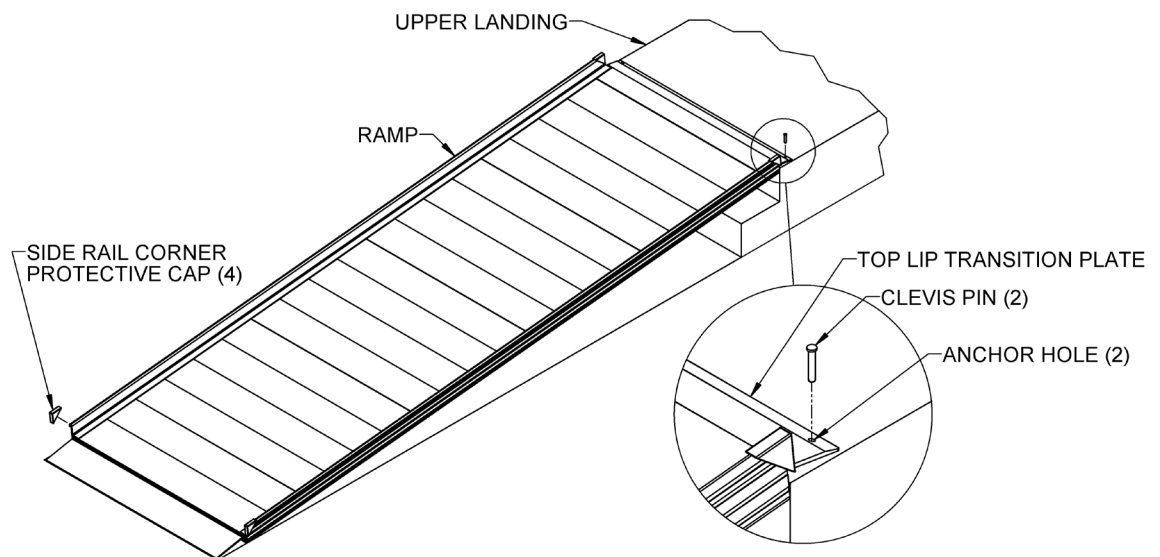



FIG. 12



9. FINAL STEPS

9.1 Handrail scratches:

9.1.1 Use sandpaper (180 grit or equivalent) for touching up minor scratches on architecturally finished handrails.

 Do NOT use abrasives on paint or powder coat.

9.1.2 Sand in the direction of the grain as shown (FIG. 13).

9.2 Final checks:

9.2.1 Ensure that all fasteners are in place and secure.

9.2.2 Walk on the assembled ramp, checking for any undue movement.

9.2.3 Ensure that the level and slope has not shifted during installation.

9.2.4 Ensure that all handrail ends have loops installed.

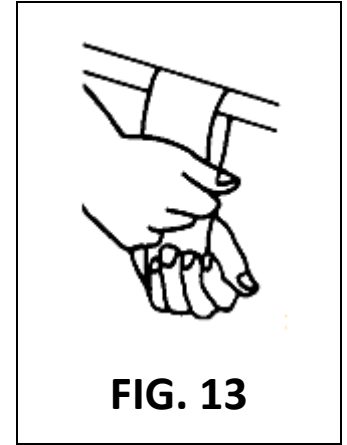



10. DEICING

 For the safety of all users, it is important to keep your system clear of snow, ice, and other debris.

 Always follow the deicing agent manufacturer's directions.

 EZ-ACCESS will not be held responsible for any injuries or damages that arise from the information provided. ALWAYS check with the deicing product's manufacturer or your local supplier to determine which method is best for your situation.

 Sodium Chloride (salt) and Calcium Chloride are particularly damaging to newly poured concrete. In addition, these chemicals should not be applied to brick and stone surfaces.

 While care has been taken to ensure that the table below is accurate, the information shown is not all-inclusive. Manufacturers of deicing products may make changes to their products as well as recommended functions and usage requirements. The deicing method you choose should be researched with your deicer supplier so you can determine which method is best for your situation.

 The information below is taken from Fact Sheet 707, Cooperative Extension Service, University of Maryland at College Park, University of Maryland Eastern Shore and was up to date at the time of this manual's publication.

PRODUCT	MIN. WORKING TEMP (°F)	SPEED OF ACTION	DAMAGES CONCRETE AND METALS?	HARMFUL TO PLANTS?
MAGNESIUM CHLORIDE	-13	VERY FAST	NO	MODERATE
CALCIUM CHLORIDE	5	FAST	YES	YES
SODIUM CHLORIDE (SALT)	18	MODERATE	YES	YES
POTASSIUM CHLORIDE	25	SLOW	OK ON OLD CONCRETE	MODERATE
CALCIUM MAGNESIUM ACETATE (CMA)	25	SLOW	NO	NO

11. INCLINE CHART

- ⚠ An incline chart is provided below, however, it is intended only as a guideline. Before use with mobility equipment, refer to your mobility equipment's owner guide for acceptable ramp usage, including proper slope/incline, chair direction, etc.; never exceed its recommendations.

RISE	RAMP LENGTH									
	2'	3'	4'	5'	6'	7'	8'	9'	10'	
3"	7.2°	4.8°	3.6°	2.9°	2.4°	2.0°	1.8°	1.6°	1.4°	
4"	9.6°	6.4°	4.8°	3.8°	3.2°	2.7°	2.4°	2.1°	1.9°	
5"	12°	8.0°	6.0°	4.8°	4.0°	3.7°	3.0°	2.7°	2.4°	
6"	14.5°	9.6°	7.2°	5.7°	4.8°	4.1°	3.6°	3.2°	2.9°	
7"		11.2°	8.4°	6.7°	5.6°	4.8°	4.2°	3.7°	3.3°	
8"		12.8°	9.6°	7.7°	6.4°	5.5°	4.8°	4.2°	3.8°	
9"		14.5°	10.8°	8.6°	7.2°	6.2°	5.4°	4.8°	4.3°	
10"			12.0°	9.6°	8.0°	6.8°	6.0°	5.3°	4.8°	
12"			14.5°	11.5°	9.6°	8.2°	7.2°	6.4°	5.7°	
14"				13.5°	11.2°	9.6°	8.4°	7.4°	6.7°	
16"					12.8°	11.0°	9.6°	8.5°	7.7°	
18"					14.5°	12.4°	10.8°	9.6°	8.6°	
20"						13.8°	12.0°	10.7°	9.6°	
22"							13.2°	11.8°	10.6°	
24"							14.5°	12.8°	11.5°	
26"								13.9°	12.5°	
28"								15.0°	13.5°	
30"									14.5°	

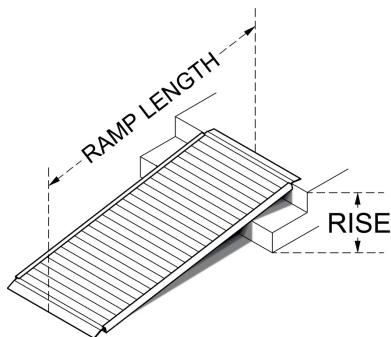

TO ESTABLISH THE PROPER RAMP LENGTH

1. Determine the incline that your chair is designed to climb.
2. Measure the rise (distance from top step, porch, van, etc. to the ground).
3. Refer to Incline Chart to find proper ramp length.
 - ⚠ At any incline, use ramp only with a qualified helper and always use a lap belt.