

User-Service Manual
Joerns® Lifting and Repositioning
Model C-HLA-2

To avoid injury, read user's manual before using.

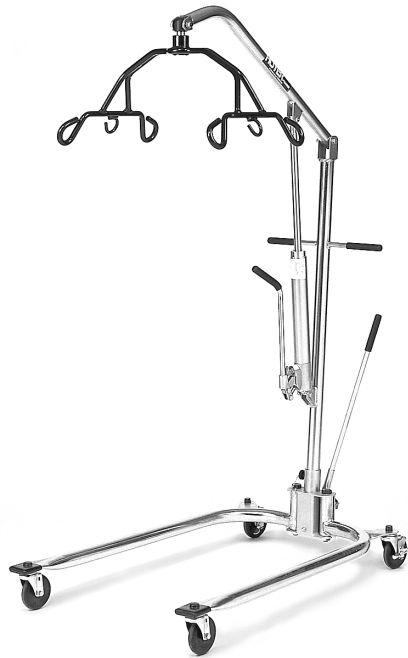

redefining patient handling

This manual contains important safety and maintenance instructions. Please read it carefully before using your patient lifter and refer to it as often as needed for safe and efficient use.

If you have any questions regarding the safe use and/or assembly, maintenance or specifications of your patient lifter, you should call Joerns Healthcare toll-free at 800.826.0270.

For service and repair, remember your authorized Hoyer dealer is able to provide the assistance you need. Save this manual for future reference. For non-homecare lifters, your maintenance department should keep this manual.

⚠Caution: For patient use, refer to the separate manual, "How to Use a Patient Lifter." If you did not receive a copy or need additional copies, contact Joerns Healthcare at 800.826.0270.

⚠Warning: Using other manufacturers' parts and accessories on Hoyer products is unsafe and may result in serious injury to patient and/or attendant. Use only Hoyer parts. Hoyer lifter parts are NOT interchangeable with other manufacturers' products. Replace any worn parts immediately.

Equipment Identification: The unit's identification number (specification, model, serial number) appears on a silver nameplate attached to the back of the lift base.

Receipt of Equipment: Upon receipt of the equipment, verify it against the packing list to ensure it is complete and inspect the equipment for possible damage due to shipping. If there is any damage, DO NOT use the equipment and notify the carrier immediately to file a claim. Provide complete information concerning damage claims or shipping errors to your supplier. Include all equipment identification numbers and group part numbers (if any) as described above along with a full description of damaged goods.

Important Precautions

⚠Warning: Do not attempt to use this equipment without understanding this manual.

To ensure safe operation, read carefully the entire manual before installing, operating or servicing this equipment.

If anything is not completely understood, please contact your supplier for more details. Failure to comply with warnings in this manual may result in injury.

Keep this manual with the lift and refer to it as required. Contents of this manual are subjected to change without prior notice to users.

Important information is highlighted by the following terms, which appear throughout the manual. Pay particular attention to the information provided under these headings.

⚠Warning: Important safety information for hazards that might cause serious injury.

⚠Caution: Information for preventing damage to the product.

Note: Information to which you should pay special attention.

Additional copies of this manual can be obtained from your supplier. Please quote the product model number.

⚠Warning: Your lift is for transferring patients only. Do not use the lift for any other purpose.

⚠Warning: Always carry out the daily check list before using the lift.

⚠Warning: Hoyer floor lifts are specifically designed for Hoyer slings and accessories. Slings and accessories designed by any other manufacturer are prohibited and will void Joerns Healthcare's warranty. Use only Hoyer slings and accessories to maintain user safety and product utility.

⚠Warning: Hoyer floor lifts are intended to be used for persons within the specified weight limit indicated for the lift. Do not attempt to lift more than the weight limit indicated.

- ⚠ **Warning:** Before attempting to transfer, the user must be assessed by a qualified professional.
- ⚠ **Warning:** Hoyer lifts must be used by qualified caregivers with proper training to work with the person to be transferred.
- ⚠ **Warning:** Only trained and qualified caregivers should transfer a person. Do not attempt to use the lift if you have not been properly trained to do so.
- ⚠ **Warning:** Always carefully plan and be prepared before attempting to transfer a person.
- ⚠ **Warning:** Do not use a sling that is not recommended for the lift.
- ⚠ **Warning:** Never use a damaged, torn or frayed sling.
- ⚠ **Warning:** Always place the sling around the user according to the sling user instructions.
- ⚠ **Warning:** Follow lifting procedures outlined in the "How to Use a Patient Lifter" manual.
- ⚠ **Warning:** Use all controls and safety features only according to the rules specified in this manual. Never attempt to force a control or button on the lift.
- ⚠ **Warning:** Do not store the lift in a shower, bath or other area with high humidity.
- ⚠ **Warning:** IMPORTANT: Keep all components of the lift clean and dry, and have electrical and mechanical safety checkpoints done as instructed in the "Maintenance" section of this manual.
- ⚠ **Warning:** Do not attempt to maneuver the lift by pushing on the mast, motor shaft, boom or patient.
- ⚠ **Warning:** Always maneuver the lift with the handle provided.
- ⚠ **Warning:** Do not push a loaded lift at speeds which exceed a slow walking pace (2.6 ft/sec.).
- ⚠ **Warning:** Inspect all precautionary labels on the equipment. Order and replace all labels that cannot be easily read.

- ⚠ **Caution:** Use pump to raise boom into position for lifting patient.
- ⚠ **Caution:** DO NOT lift up on end of boom when positioning to prepare for lifting patient as this causes air to be drawn in under ram, preventing hydraulic pump from lifting when handle is pumped.
- ⚠ **Caution:** DO NOT press down hard on handle beyond its normal downward stopping point.
- ⚠ **Caution:** It is a common occurrence after a few hours of non-use for the boom to lower with no weight suspended from the end of the boom. This does not indicate a faulty pump but is a trait common to hydraulic equipment.
- ⚠ **Caution:** If trouble develops or you have questions regarding the hydraulic pump, call Joerns Healthcare Customer Care at 1-800-826-0270 (be sure to provide your serial number and date purchased). DO NOT attempt to lift someone with a faulty hydraulic pump.
- ⚠ **Warning:** DO NOT wash slings with bleach. Bleach will damage material. Slings can suffer damage during washing and drying.
- ⚠ **Warning: Possible Injury or Death.** Always check slings before use. Bleached, torn, cut, frayed or broken slings are unsafe and could result in serious injury or death to patient/caregiver. Destroy and discard worn slings. DO NOT alter slings.
- ⚠ **Warning:** Inside center attachment points on cradle are used only for Hoyer slings with chains or straps. The four outside attachment points are used for Hoyer 4-point slings.
- ⚠ **Warning: Possible Injury or Death.** Cradle Center Post must protrude below the bottom of the cradle center pivot assembly (approximately 1/16"). If cradle center post is flush or recessed, excessive wear may have occurred. Worn cradle parts could fail resulting in serious injury or death to patient and/or attendant.

Table of Contents

Important Precautions	2
Specifications	4
Assembly.....	5
Inspection of Hydraulic Pump Stud.....	7
Operation.....	8
Leg Spreader Operation	
Lifter Maintenance Checklist.....	10
Troubleshooting	11
Hoyer 4-point Sling Information.....	12
Warranty	14

Specifications

Base	Adjustable U
Maximum Weight Capacity	400 lbs.
Lift Range of Boom	29" - 80"
Width of Base	24" - 39.5"
Length of Base	41"
Base Clearance	5.5"
Finish	Chrome

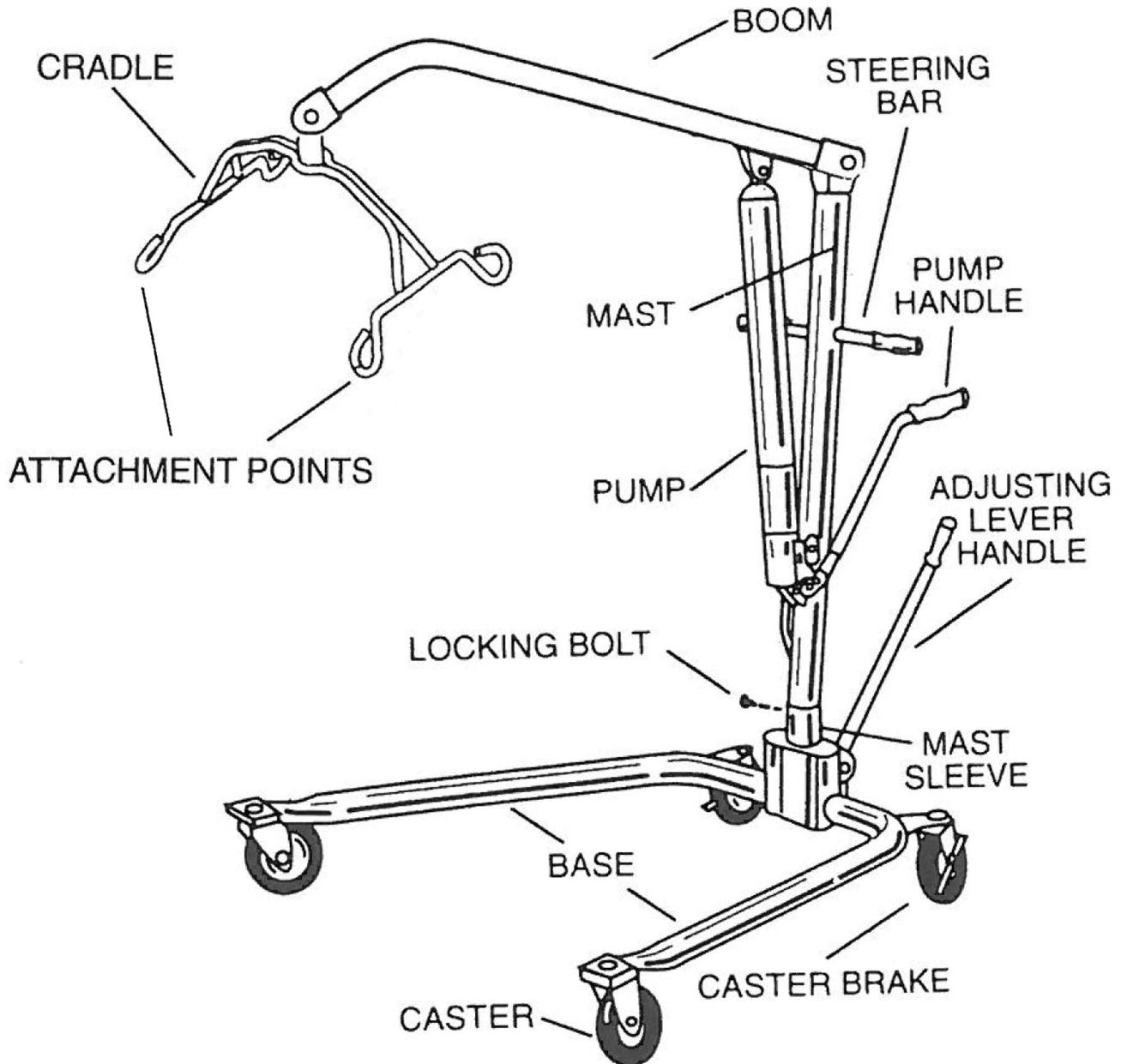

Assembly

Recommended Tools: two 9/16" wrenches, 1/8" hex wrench, 5mm hex wrench

⚠Warning: Inside center attachment points on cradle are used only for Hoyer slings with chains or straps. The four outside attachment points are used for Hoyer 4-point slings.

⚠Warning: The large thrust washer must be inserted on the cradle hanger post (Figure 7, pg 6). If washer is not present, the cradle hanger post and cradle center may wear prematurely. Worn cradle parts could fail, resulting in injury to resident/caregiver. Hanger post should protrude from the cradle center by 1/16th inch.

⚠Warning: Never lock wheel locks or block wheels when lifting someone. Wheel locks are provided for parking the lifter only. The only exception is when lifting a patient from the floor - the locks should be engaged during a floor lift.

1. Carefully unpack Hoyer Lifter. Check for swivel bar/6-point cradle and adjusting lever handle.
2. Insert mast in base sleeve (Figure 1). Be sure notch on end of mast fits over bolt in bottom of mast sleeve. Mast must lock into position in base sleeve, making it impossible to rotate. Check carefully to be certain mast cannot rotate.
3. Make certain boom points in same direction as base legs. Thread mast safety lock and stud into threaded hole in mast sleeve. Tighten firmly, locking mast into base (Figure 2). Keep mast and base locked at all times except when removing mast from base for storage.
4. Insert boom end into hole in yoke hinge at the top of mast. Fasten bolt and nut (Figure 3). Be certain hex of bolt head fits into formed hex on side of hinge and that plastic washer is under lock nut.
5. Attach hydraulic pump to boom (Figure 4).

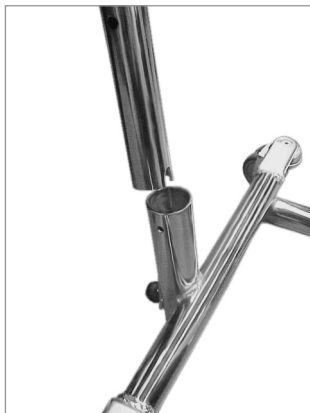

Figure 1

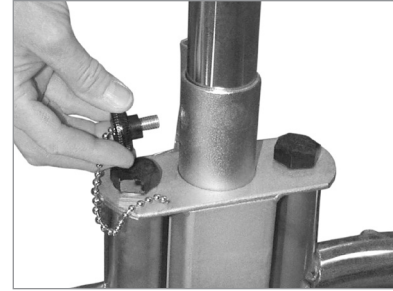

Figure 2



Figure 3



Figure 4

6. Cradle Attachment

- a. Remove nut and bolt from cradle.
- b. Hold cradle in position at the end of the boom and align the holes of the pin and cap with the holes in the boom end fork.
- c. Insert supplied bolt and washer through boom fork, cradle cap and pin. Washers must be placed on the outside of the fork under bolt head and under the nut (Figure 5). Place nut on bolt, and secure tightly (Figure 6).
- d. Swivel cradle to check for free movement.

7. Attach adjusting lever handle into base (Figure 7).
8. Wheel locks are provided for parking. To lock caster, step on cam lever on side of caster. To unlock, step on highest cam lever (Figure 8).

⚠Warning: The large thrust washer must be inserted on the cradle hanger post as shown in Figure 7. If washer is not present, the cradle hanger post and cradle center may wear prematurely. Worn cradle parts could fail, resulting in injury to resident/caregiver. Hanger post should protrude from the cradle center by 1/16th inch.



Figure 6



Figure 5



Figure 7

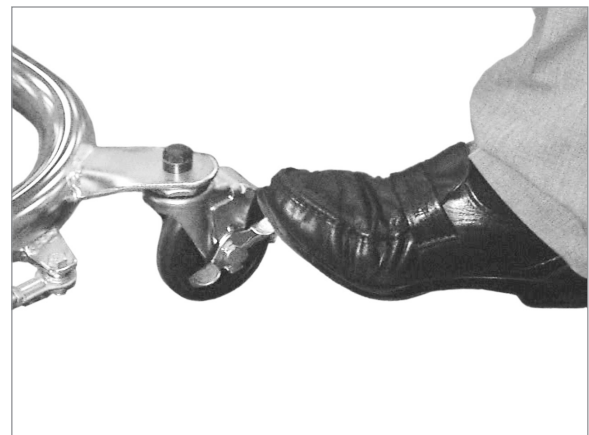

Figure 8

Inspection of Hydraulic Pump Stud

Tools required: 5mm hex wrench, 9/16" combination wrench

1. Observe orientation of "U" bracket (3) and rotation limit bracket (4) prior to removing pump from lift.
2. Remove hydraulic pump from lifter by removing bolts at mast and boom attaching points. Place on suitable work surface.
3. Loosen nut (2) by three turns at base of pump using the 9/16" combination wrench. If the stud turns while loosening, use the 5mm hex wrench to prevent it from turning.
4. Check tightness of stud using the 5mm hex wrench. Firmly tighten the stud by turning in a clockwise direction when viewed from the bottom.
5. Verify all components 1, 2, 3, 4, and 5 are correctly assembled (Figure 9).
6. Tighten nut (2) until it lightly contacts the nylon washer (1). Loosen the nut (2) by 1/2 turn so that the pump rotates freely in "U" bracket (3). Check that the stud is still tight using the 5mm hex wrench.
7. Reassemble the pump to lift (reverse of step 2). Tighten nuts until contact is made with "U" brackets of mast and boom. Then loosen by 1/2 turn. Pump should be free to rotate. Verify that "U" bracket (3) and rotation limit bracket (4) are correctly oriented to mast per diagram.
8. Check for free rotation of pump after assembly.

▲Caution: The pump should rotate freely prior to lifting a patient.

▲Caution: Place the pump handle in a comfortable position prior to lifting a patient. Do not attempt to rotate the pump while lifting a patient.

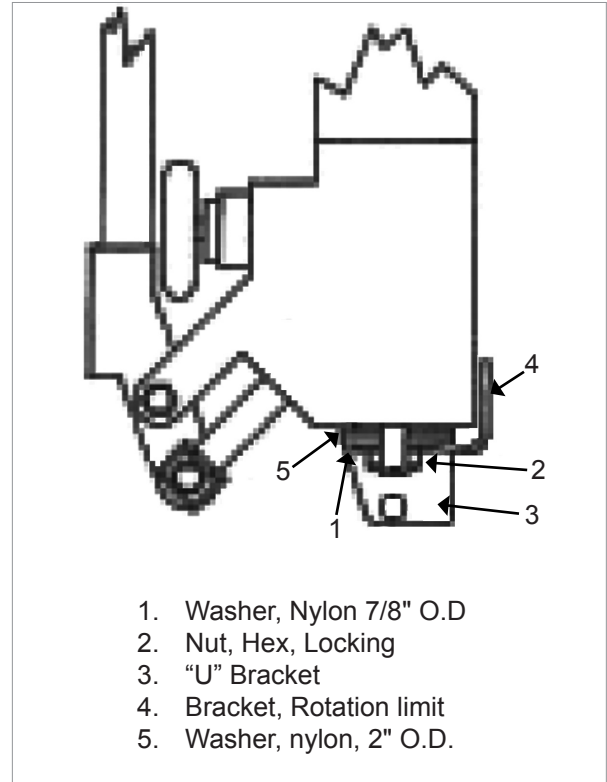

Figure 9

Operation

⚠Warning: Lifters can tip over. Keep base widened for stability. NEVER lock wheel locks or block wheels when lifting someone. Wheel locks are provided for parking. The only exception is when lifting a patient from the floor - the locks should be engaged during a floor lift. To lock casters, step on cam lever on side of casters. To unlock, step on highest cam lever.

To Raise Lifter

1. Tighten hydraulic pressure release knob by turning it clockwise. Release knob is located on pump near pump handle (Figure 10). Base of lifter must be spread to widest possible position to maximize stability (Figure 11).
2. Pump hydraulic handle (Figure 12). Do not lock rear casters. If needed, lifter base will move slightly to adjust for balance.

To Lower Lifter

1. Open hydraulic pressure release knob by turning it counter-clockwise, not more than one full turn (Figure 13).
2. Guide descent. Push gently on knees to attain correct sitting posture while lowering.
3. After patient reaches seat, push down on boom to slacken chains.

⚠Warning: Lifters can tip over. Keep base widened for stability. NEVER lock wheel locks or block wheels when lifting someone. Wheel locks are provided for parking. The only exception is when lifting a patient from the floor - the locks should be engaged during a floor lift. To lock casters, step on cam lever on side of casters. To unlock, step on highest cam lever.



Figure 11



Figure 12



Figure 10



Figure 13

Note: Hydraulic Pump

1. Do not lift up on end of boom to position for lifting patient as this causes air to be drawn in under ram, preventing pump from lifting when handle is pumped.
2. Do not press down hard on handle when bottom of stroke is reached.
3. It is a common occurrence after a few hours of non-use for the boom to lower with no weight suspended from the end of the boom. This does not indicate a faulty pump but is a trait common to hydraulic equipment.
4. If trouble develops with the hydraulic pump, remove it and call your Joerns Healthcare Supplier to receive an RMA. Provide serial number (located on the base of the unit) and date purchased. Do not attempt to lift someone with a faulty hydraulic pump.
5. Inspect the mounting stud at the base of the pump. Refer to “Inspection of Hydraulic Pump Stud” section.

Leg Spreader Operation

To widen or narrow the base, pull adjustment handle back to unlock (Figure 14). Handle can be moved to the right to widen the base (Figure 15) or to the left to narrow the base (Figure 16).



Figure 14



Figure 15



Figure 16

Lifter Maintenance Checklist

Only qualified persons should service and repair Hoyer lifters. Regular maintenance of lifters and accessories is necessary to assure proper and safe operation. Read and observe the following recommended instructions.

Item	Initially	Before each use	Bi-Monthly
Base and Wheels			
Base is even and level (all four wheels are on the floor)	✓	✓	
Wheel bolts are tight	✓	✓	
Wheels swivel and roll easily	✓	✓	
Base Adjustment			
Base locks securely, all parts are present	✓	✓	
Base opens and closes smoothly	✓	✓	
Check spreader lock and all hardware for wear		✓	
Mast			
Mast fully engaged and locked into mast sleeve	✓	✓	
Inspect for bends or deflections		✓	
Inspect all bolts and nuts for wear and tightness		✓	
Boom			
Inspect all bolts and nuts for wear and tightness		✓	
Inspect to ensure the boom is centered between the base legs	✓	✓	
Cradle			
Check hanger post for wear or damage. Replace post if wear exceeds 1/16".		✓	
Check sling attachments for wear or deflection		✓	
Swivel Bar			
Check nut at bottom of swivel bar hook and eye hook on boom for wear			✓
Check for two nylon washers between nut of swivel bar hook and underside of swivel bar assembly	✓		
Pump Assembly			
Tighten seals around piston with spanner wrench provided	✓		✓
Pump handle and valve work smoothly	✓	✓	
Check for oil leakage, a light film is normal, but not to the point of dripping.	✓	✓	
Check the 5mm mounting stud at the base of the pump for tightness			✓
Slings and Hardware			
Check metal parts, nuts and bolts for wear, damage or loosening		✓	✓
Check all nuts, bolts and screws for wear and tightness			✓
Check slings and web straps for wear or damage		✓	

Lifter Maintenance Checklist continued...

Item	Initially	Before each use	Bi-Monthly
Lubrication			
Oil all pivot joints, including:			
Top of mast where boom attaches			✓
Top and bottom of actuator mounting			✓
Pump handle hinge			✓
Use a light grease to lubricate base adjustment lock plate and all rotating hardware.			✓
Wheel and swivel bearings			✓
Cleaning*			
Use mild soap to clean; dry thoroughly.		✓	
Apply auto or appliance wax			✓
Keep painted surfaces clean from oil		✓	

* Do not wash under water pressure.

Troubleshooting, Power Unit

Symptom	Action
Handle mounting holes loosening or enlarging	<ul style="list-style-type: none"> Periodically oil the pivot point
Jack lowers with patient suspended	<ul style="list-style-type: none"> Check to make sure the pressure release knob is completely closed. Check valve not sealing. Pump handle rapidly several times, then open pressure release knob and pull down on boom. Repeat two or three times. Replace the jack.
Jack fails to lift to full height	<ul style="list-style-type: none"> Air in oil under ram– pump unit up as far as it will go. Open pressure release knob and pull down on boom to lowest position. Repeat until lift raises to full height. Unit may be low on oil– remove jack from lift, collapse ram. Remove socket screw (located on top of top cap) and put 1oz. of #10 weight hydraulic oil in at a time until the jack ram moves the proper distance. <p>NOTE– Proper amounts of oil for a jack when completely empty are 7 3/4 oz. for 12" stroke; 11 1/2 oz. for 17" stroke; 3 3/4 oz. for 6" stroke; 12 1/2 oz. for 19" stroke.</p>
Oil leaking from around piston	<ul style="list-style-type: none"> Replace the jack.
Oil leaking around rim of top cap	<ul style="list-style-type: none"> Replace the jack.
Unit will not lower	<ul style="list-style-type: none"> Lay jack on its side. Remove and clean release cartridge making sure small holes are cleaned out with pin or small diameter wire. Replace the jack.
Jack is noticeably loose in the mounting bracket located at the base of the jack.	<ul style="list-style-type: none"> Refer to “Inspection of Hydraulic Pump Stud” section to tighten the mounting stud for the jack.

Hoyer 4-point Sling Information

Warning: Torn, cut, frayed or broken slings could fail resulting in serious injury or death to patient. Use slings in good condition only. Destroy and discard old, unusable slings.

Note: Do not use any other manufacturer's sling with the C-HLA-2 Lifter.

Note: Do not use Hoyer slings with any other manufacturer's lift.

Patient Size Guide

	A	B	Weight
	inch (cm)	inch (cm)	lbs (kg)
Large	28 (70)	19 (47)	198-400 (90-191)
Medium	24 (61)	19 (47)	99-210 (45-95)
Small	18 (46)	15 (38)	55-110 (25-50)

*Patient's weight to sling size information is an approximation only.

Patient can be raised 4" higher by hooking up the inside strap to the cradle.



Example of label found on back of Hoyer Slings

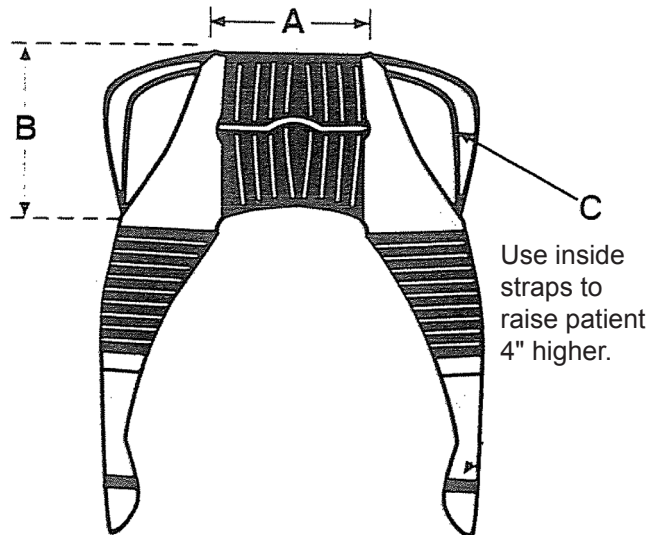



Notes:

Joerns Healthcare Warranty Program for Hoyer® Classic Lifts

Your Hoyer Classics Lifts are warranted for one (1) year after purchase by the original consumer/owner.

Components are warranted as follows:

1. Lifter structure; base, mast, boom, and suspension cradle.
2. Hydraulic pump/jack (for manual lifters).
3. Electronic control box, hand pendant, actuator and battery (for power lifters).

All other non-durable components, such as rubber parts, plastic parts and painted surfaces, are warranted for one (1) year from original consumer/owner purchase. These non-durable components are subject to normal wear and replacement.

Damage caused by use in unsuitable environmental conditions or failure to maintain the product in accordance with user and service instructions is not covered. Any alteration, modification, or repair unless performed by or authorized in writing by Joerns Healthcare will void this warranty.

This warranty applies in the USA only. Check with your supplier to find out if international warranties apply.

Parts

Hoyer Classics Lifts contain various parts that wear from normal use. These parts, such as rubber parts, plastic parts and painted surfaces are not covered under the one-year warranty but are covered for 90 days after date of purchase.

Joerns Healthcare's obligation under this warranty is limited to supplying replacement parts, servicing, or replacing, at its option, any product which is found by Joerns Healthcare to be defective.

Warranty replacement parts are covered by the terms of this warranty until the product's original warranty period expires.

When requested by Joerns Healthcare, parts must be returned for inspection at the customer's expense. Credit will be issued only after inspection.

Service

Most service requests can be handled by the facility Maintenance Department with assistance from the Joerns Healthcare Product Service Department.

Should a technician be required, one will be provided by Joerns Healthcare, at our discretion. Only the Joerns Healthcare Product Service Department can dispatch authorized technicians.

This warranty is extended to the original purchaser of the equipment.