



HAUSMANN INDUSTRIES, INC.

Installation/Operation Instructions

Model # 1580 – ADA Convertible “Space Saver” Staircase

Corner Set-Up

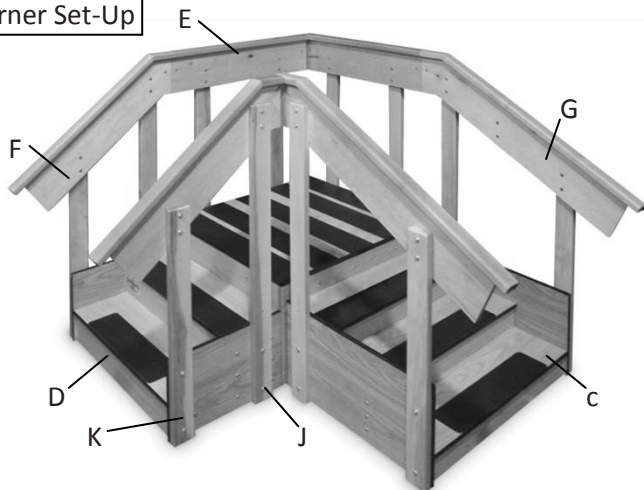

Figure 1: Model #1580 Corner Set-Up

Straight Set-Up

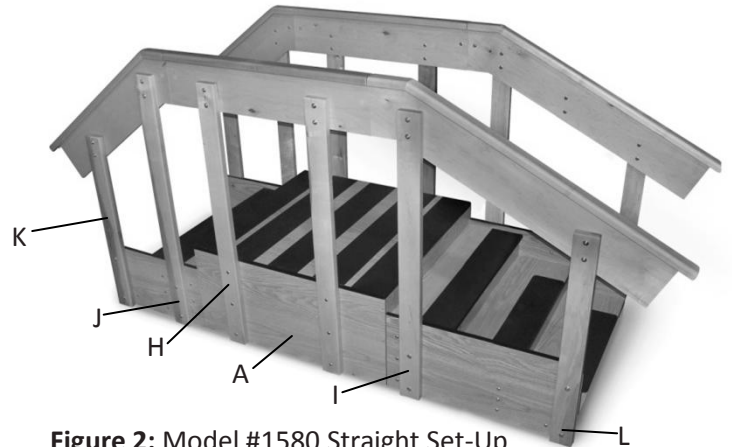







Figure 2: Model #1580 Straight Set-Up

Model # 1560-65-036		
PART	QTY	DESCRIPTION
A	1	Base
C	1	4-Step Stair Case
D	1	3-Step Stair Case
E	2	Straight Handrails
F	2	Medium Handrails
G	2	Long Handrails
H	4	52" Uprights for Straight Handrails
I	2	47 1/4" Uprights for Handrails
J	2	46 1/2" Uprights for Handrails
K	2	40 1/4" Uprights for Handrails
L	2	37 1/2" Uprights for Handrails

Tools Required:
 Allen Wrench (included)
 Philips Screw Driver

2 People Required for Assembly

Product Specifications				
Model	Length	Width	Height (Platform)	Weight Capacity
1580 (Straight)	91"	36"	18"	350 lbs
1580 (Corner)	58" x 69"	36"	18"	350 lbs

HARDWARE BAG		
PART	QTY	DESCRIPTION
P	8	 → 3 1/4" Allen Hex Head Bolt
Q	12	 → 2 3/8" Allen Hex Head Bolt
R	32	 → 45mm Pan Head/Philips screw
S	32	 → 16mm Barrel Bolt
T	1	 → 4 mm Allen Wrench
U	32	 → Flat Washer

A) INSTALLATION INSTRUCTIONS:

1. Unpack all contents from shipping carton; confirm correct parts & quantity.
2. Place all the parts in a desired location for assembly. Model # 1580 can be assembled in two configurations (Straight or Corner).
3. Layout the base 'A' and Step sections 'C' or 'D' by mounting the wooden 'cleat' on opposite sides for a Straight setup or next to each other for a Corner setup.

4. Lift the Step sections up and over the “cleat” to set them into place as shown in Figure 3.

NOTE: Each upright and step section is machined with an indexing mark to note where each upright and handrail are supposed to be installed. A series of 1, 2 or 3 dots on the uprights will match up to the same dots on the outside of the step section. Attach the uprights so that the dots folds on top of each other as shown in Figure 4.

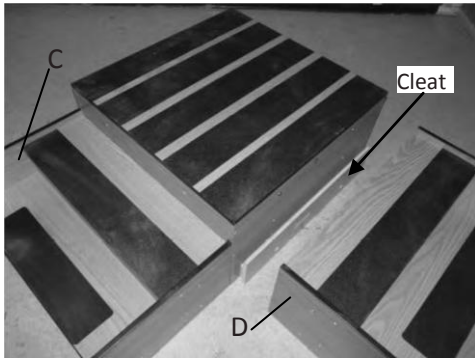

Figure 3: Base with Step sections

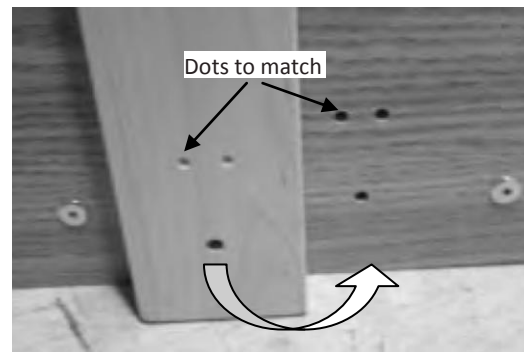

Figure 4: Dots on Upright & Steps

5. Attach uprights ‘H’ on the open ends of the base ‘A’ using Hex head bolts ‘P’ and Allen key, with the dots facing inwards as shown in Figure 5. (It may require to remove (2) bolts from the upper mounting positions on the center platform to attach the uprights or position the step sections). **HAND TIGHTEN ONLY!**

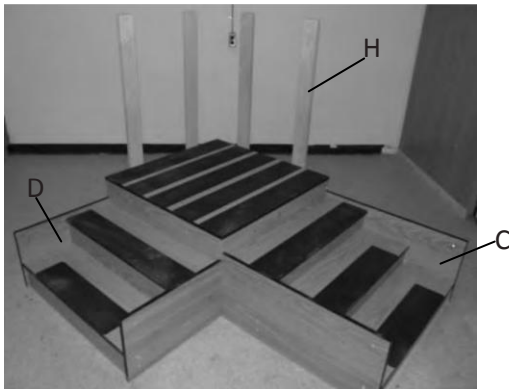

Figure 5: Base with Uprights ‘H’

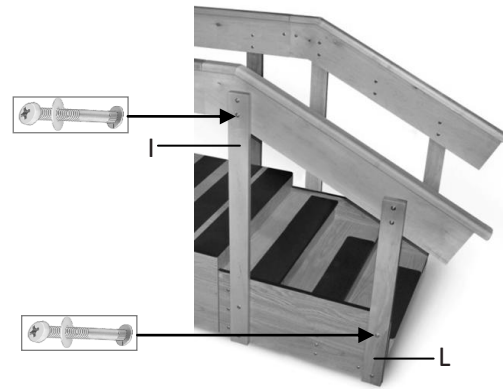

Figure 6: 4-Step Stair with uprights

6. Attach uprights (‘I’ & ‘L’ respectively) onto the 4-Step section, by matching up the dots on the upright with step section using four Hex head bolts ‘Q’ on the bottom of the uprights and two on the top of the 3rd step, and two Pan Head/Philips screw ‘R’ with Flat Washer ‘U’ and Barrel Bolt ‘S’ on the rest as shown in Figure 6.

7. Attach uprights (‘J’ & ‘K’ respectively) onto the 3-Step section using four Hex head bolts ‘Q’ on the bottom of the uprights and two on the top of the 2nd step and two Pan Head/Philips screw ‘R’, Flat washer ‘U’ and Barrel Bolt ‘S’ on the rest as shown in Figure 7.

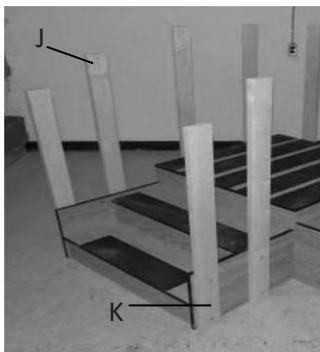

Figure 6: 3-Step Stair with uprights

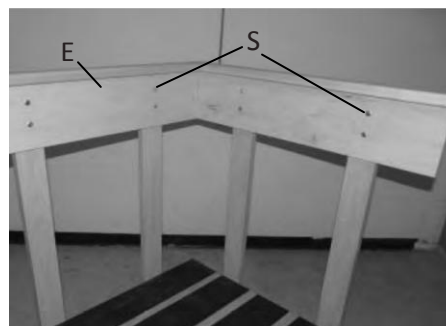

Figure 7: Straight Handrails ‘E’

8. Insert the Barrel Bolt ‘S’ into the straight handrails on the opposite side of the dots as shown in Figure 7.

9. Attach the straight handrails 'E' over the Base 'A' on the inside part of the uprights so that Barrel bolts on the handrails should be facing inwards using Pan Head/Philips screw 'R' with Flat washer 'U' as shown in Figures 8 & 7. At this point loosely fit the handrail on the uprights.

NOTE: Each Handrail is produced with either a 'hook' or a 'cup' that are designed to 'lock' into each other when assembled. They also have an inner and outer face, so it is important that they are installed in the correct location.

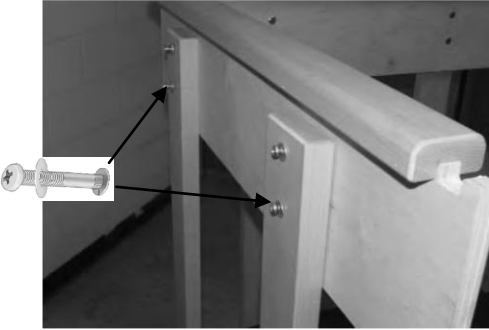

Figure 8: Straight Handrails attached

10. For the corner setup the corner is 'locked' together with the 'hook' & 'cup' fitting as shown in Figure 7 and for the straight setup the remaining handrails can only be setup one way for correct assembly.

11. Insert the Barrel bolts 'S' in each of the medium and long handrails 'F' & 'G' respectively the same way it was inserted in straight handrails.

12. Attach the Medium handrails 'F' on the inside part of the 'J' & 'K' uprights so that Barrel bolts 'S' on the handrails should be facing inwards using Pan Head/Philips screw 'R' with Flat washer 'U' as shown in Figures 9.

NOTE: Fit the 'hook' or 'cup' into the handrail next to it. Once all the handrails are installed, tighten all screws and bolts to secure the structure.

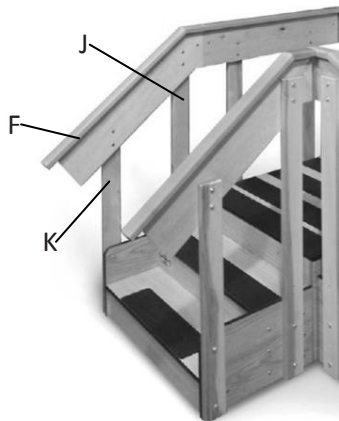

Figure 9: Medium Handrail 'F'

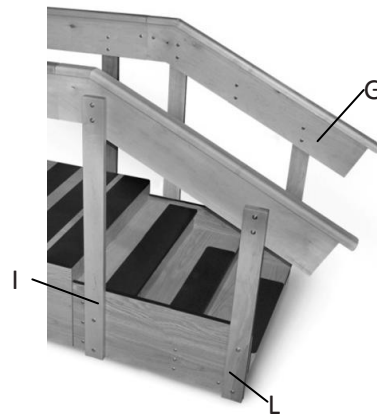

Figure 10: Long Handrail 'G'

13. Attach the Long Handrails 'G' on the inside part of the 'I' & 'L' uprights so that Barrel bolts 'S' on the handrails should be facing inwards using Pan Head/Philips screw 'R' with Flat washer 'U' as shown in Figures 10.

NOTE: Fit the 'hook' or 'cup' into the handrail next to it. Once all the handrails are installed, tighten all screws and bolts to secure the structure.



CAUTION: PREVENTATIVE MAINTENANCE REQUIRED

1. Inspect hex bolts and other mechanical fasteners periodically. Tighten bolts, screws or connections if loose (Tighten until snug, but do not overtighten). Failure to do so may result in serious injury.
2. Do not use if any loose fasteners are found.
3. Discontinue use of any product that is NOT in proper working order until situation is rectified. Failure to do so may result in serious injury.