



Linen Inspection Table

Product Overview

- Large illuminated work surface for inspection of linen drapes and packing wraps
- High output sealed fluorescent fixtures provide bright consistent lighting
- Optional lower shelf feature provides extra storage space when required
- Tubular legs are available with optional heavy-duty grey non-marking caster assemblies with brakes
- Stainless steel legs / frame ensures long life and durability

Product Details

- Stainless steel construction with sealed translucent plexiglass work surface
- Provides maximum support and stability and is complete with height adjustable feet
- Hospital grade power cord (10 feet / metres) and light switch are CSA Approved
- Lamp assemblies are easily accessible for bulb replacement when required

Product Selection

Model no.	Description	Dimension (L x W x H)
SP-8210	Linen Inspection Table (Standard Length)	72 in x 32 in x 36 in (1829 mm x 813 mm x 914 mm)
SP-8215	Caster Kit for Standard Table (Set of four) <i>Factory Installed*</i>	
SP-8220	Linen Inspection Table (Extended Length)	92 in x 32 in x 36 in (2337 mm x 813 mm x 914 mm)
SP-8225	Caster Kit for Extended Table (Set of six)	

**Note that the casters cannot be added to an order after it has been placed.*

Sterile Processing IMPERIAL SURGICAL

Since 1935



Standard Length Table

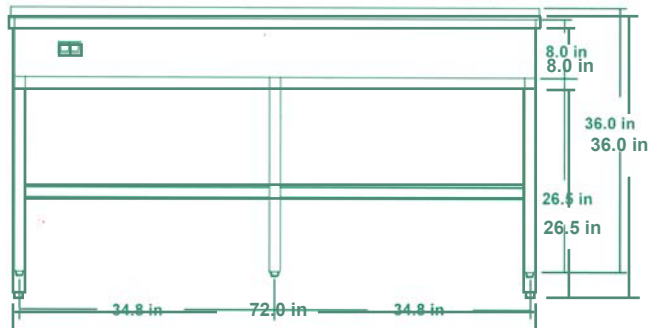
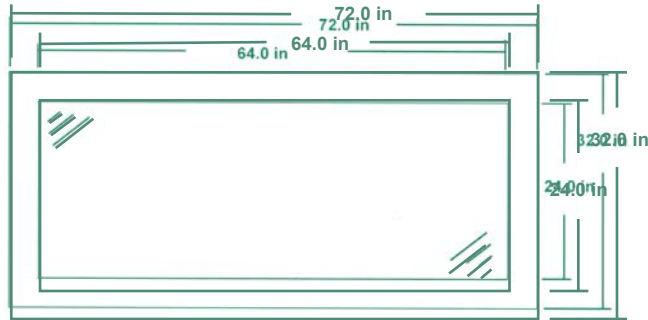

Extended Length Table

