

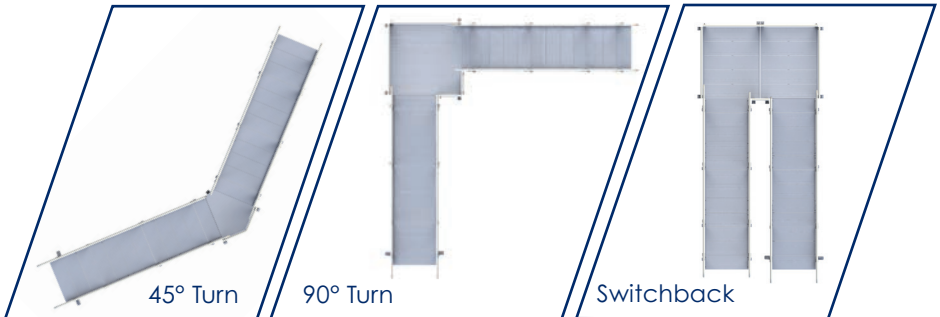

- Ramp sections welded in lengths of 3', 4' & 5'
- Can be easily moved or reconfigured
- Durable and weather resistant
- Little or no site preparation required
- All aluminum construction
- Little or no maintenance
- 45° and 90° turns and switchbacks
- Multiple configurations possible
- ADA handrail extensions, guardrails and gates available
- Accommodates a rise up to 60"
- Comes with a Limited Lifetime Warranty*
- Optional powder coated handrails



Multiple configurations possible!





LIMITED **LIFETIME**
WARRANTY



Width	36", 42", & 48" Usable
Length	Variable to meet your needs
Load Capacity	100 lbs. per square foot
Slope	Adjustable - 1:12 Recommended
Floor	Slip resistant grooved aluminum
Ramp Edge Protection	4" Curbs Meet ADA Standards
Handrails	Double 1 1/2" bar - 34" standard height

* Powder coated handrails not included in Limited Lifetime Warranty.

PVI Ramps Are
Proudly Made
In USA



PVI