

Assembly Manual

PATHWAY® Aluminum Wheelchair Ramp Kit

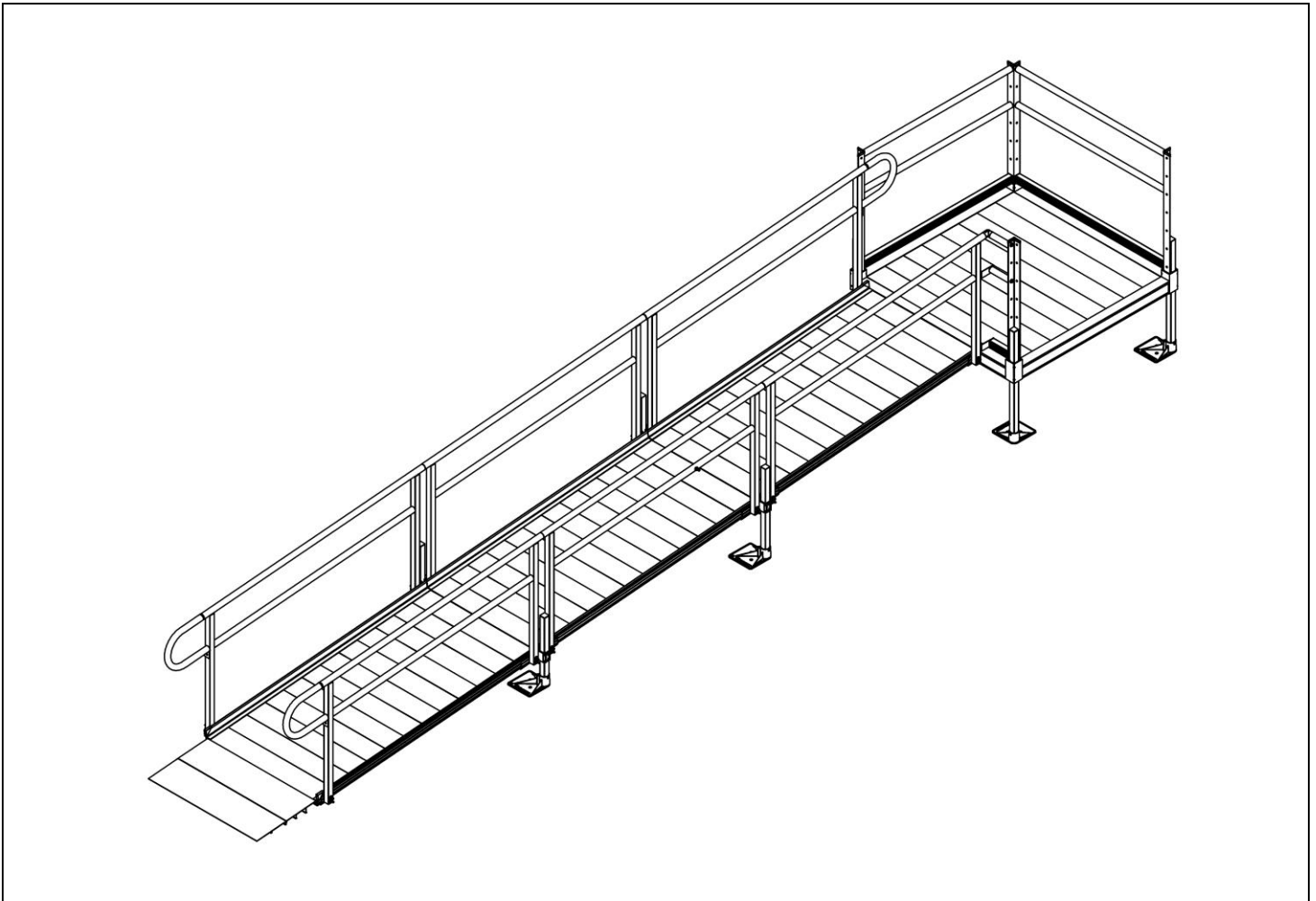

**Configuration shown with straight ramp run and 4' x 4' top platform.
However, there are multiple configurations and sizes
available. See inside manual for additional information.**

LIFETIME WARRANTY. Please register at www.ezaccess.com/warranty-satisfaction.

© EZ-ACCESS®, a division of Homecare Products, Inc. *All rights reserved.*

All text and images contained in this document are proprietary and may not be shared, modified, distributed, reproduced, or reused without the express written permission of EZ-ACCESS.



Manufactured in the USA

21123 REV 09-19-2022



ATTENTION INSTALLER and END USER

- For residential use only!
- Maximum weight capacity is 1,000 lbs.; never exceed weight capacity.
- Read this manual in its entirety, ensuring you understand all instructions and warnings prior to ramp assembly and use.
- Please read and become familiar with the 'MAINTENANCE AND SAFETY' section of this manual.
- Fill out online warranty registration.

IMPORTANT SHIPPING INFORMATION

- Immediately inspect for damage or missing parts. If damaged or missing parts are noted, DO NOT INSTALL OR USE.
- Each system is shipped with a packing list. Confirm all items are present before starting installation. Also check for shipping damage immediately upon receipt and note any freight damage on freight bill while driver is still present. Contact shipper right away with any freight damage concerns. In most cases, freight damage claims will not be allowed unless noted on the freight bill. Pictures of damage before the unit is unpacked can be very helpful.

TOOLS TYPICALLY REQUIRED

- | | |
|--------------------------------|--|
| ✓ 1/2" SOCKET OR 1/2" WRENCH | ✓ BOX KNIFE |
| ✓ 9/16" SOCKET OR 9/16" WRENCH | ✓ HAMMER |
| ✓ 5/16" SOCKET OR 5/16" WRENCH | ✓ LEVEL |
| ✓ POWER DRILL | ✓ FILE |
| ✓ #2 PHILLIPS SCREW DRIVE | ✓ RUBBER MALLET |
| ✓ PLIERS | ✓ 1/4" MASONRY DRILL BIT (IF INSTALLING TO CONCRETE) |
| ✓ 1/8" DRILL BIT | ✓ DIGGING TOOLS (IF AN OBSTACLE NEEDS TO BE REMOVED) |
| ✓ 5/16" DRILL BIT | ✓ HACKSAW |
| ✓ 5/32" ALLEN WRENCH | ✓ 25' TAPE MEASURE |
| ✓ 3/16" ALLEN WRENCH | ✓ CONSTRUCTION ADHESIVE |

INTRODUCTION

Throughout this manual, the term “system” refers to the entire PATHWAY® Aluminum Wheelchair Ramp Kit, including all components and hardware which are intended to be assembled on the PATHWAY Aluminum Wheelchair Ramp Kit.

SYMBOLS

- ⚠ The **WARNING** symbol indicates a potentially hazardous condition/situation. The safety warnings throughout this manual, and on your equipment, if any, are for the protection of people and property. Failure by any operator to abide by safety warnings will result in a waiver of all liabilities, loss of your warranty, and could result in equipment damage and or failure, property damage, risk of serious bodily injury, and or death. The symbol may appear in various colors and in conjunction with other symbols and with or without the written word “WARNING”.
- 👉 The **NOTE** symbol indicates important information. Failure to obey all notes could result in improper operation, less-than-optimum equipment performance, and at the sole discretion of the equipment manufacturer, may void your warranty. The symbol may appear in various colors and in conjunction with other symbols and with or without the written word “NOTE”.

WARNINGS

- ⚠ Maximum weight capacity is 1,000 lbs.; never exceed weight capacity.
- ⚠ Prior to assembly and use, read and follow all instructions, warnings, and labels. Following all instructions and obeying all warnings before and during use is necessary for safe operation. For additional information or to obtain replacement copies of instructions or labels, call 1-800-451-1903.
- ⚠ For people and mobility equipment only; not for commercial use.
- ⚠ Consult local building codes regarding securing the system for wind loads.
- ⚠ Before use with mobility equipment, refer to your mobility equipment's owner guide for acceptable ramp usage, including proper slope/incline, chair direction, etc.; never exceed its recommendations.
- ⚠ Only use the system with a qualified helper.
- ⚠ Always use a lap belt if using the system with mobility equipment.
- ⚠ If walking on the system, handrails are required and must be installed.
- ⚠ Before each use, check the system for worn, loose, or damaged parts. If you find any of these conditions, do not use the system and contact your dealer for service or repairs; failure to do so may result in serious injury.
- ⚠ Do not use the system if it is damaged or unstable.
- ⚠ Do not tamper with, attempt to repair, or modify any portion of the system.
- ⚠ Ensure that the landings the system will be placed on are substantial and of sound construction.
- ⚠ Use only if the secure, unobstructed, level landings can support, at minimum, the same weight capacity as the system (1,000 lbs.).
- ⚠ Ensure that the system is securely anchored before each use.
- ⚠ Use only if sufficient maneuvering room is available at both ends of the system to assure safe travel when entering and exiting the system.
- ⚠ Do not walk, sit, stand, etc. on the system until the installation is complete.
- ⚠ Consult local building codes regarding securing system for wind loads.
- ⚠ Keep the system clear of debris and clutter. Do not use if walking surface is unsafe.
- ⚠ Confirm the system is correctly leveled and positioned securely. Periodically check for ground shifts.
- ⚠ Never place anything on, under, or attach anything to system.
- ⚠ Only use components supplied or approved by manufacturer with system.
- ⚠ Do not sit, stand, or climb on guards, gates, or handrails.
- ⚠ Do not use any part of the system to support planters, lights, decorations, etc.

WARNINGS, CONT'D.

- ⚠** Do not run, jump, or play on or around the system, including climbing on or between the handrails.
- ⚠** Improper use of the system could result in serious injury.
- ⚠** Properly support and restrain system in transit or storage.
- ⚠** Do not use the system if its surface is covered with ice, snow, dirt, leaves, or other debris. Remove all accumulations and sweep the surface clean before use.
- ⚠** The system may be slippery in wet conditions; use caution as traction may be reduced.
- ⚠** Before each use, check the system for worn, loose, or damaged parts. If you find any of these conditions, do not use the system and contact your dealer for service or repairs; failure to do so may result in serious injury.
- ⚠** Always exercise caution when handling, installing, and or using the system.
- ⚠** For additional care, usage, or general safety information, please call 1-800-451-1903.
- ⚠** Aluminum conducts electricity. Do not use or handle the system around live wiring or during electrical storms.

TABLE OF CONTENTS

<u>SECTION 1: CONFIGURATIONS</u>	5
<u>SECTION 2: BASIC SYSTEM COMPONENTS</u>	6-9
<u>SECTION 3: PLATFORMS</u>	
INSTALL PLATFORMS	10
INSTALL SUPPORT TUBES AND FEET, THEN ADJUST PLATFORM HEIGHT	11-12
CONNECT TWO PLATFORMS TOGETHER	12-14
INSTALL UNIVERSAL ANGLE BRACE – PLATFORMS	14
<u>SECTION 4: RAMPS</u>	
CONNECT RAMP SECTIONS	15
INSTALL RAMPS ON PLATFORMS	16
ATTACH SUPPORT LEG BRACKETS AND LEGS TO RAMPS	17-18
INSTALL UNIVERSAL ANGLE BRACE – RAMPS	19
INSTALL RAMP GROUND TRANSITION	20
INSTALL A SINGLE RAMP RUN TO AN EXISTING STRUCTURE	21
ANCHOR RAMP UPPER TRANSITION	22
ANGLE RAMPS WITH RESPECT TO PLATFORMS, PORCHES, OR DECKS	22-23
BRIDGE PLATE	23
<u>SECTION 5: HANDRAILS</u>	
RAMP HANDRAILS	24
ASSEMBLE PLATFORM HANDRAILS	25
INSTALL PLATFORM HANDRAILS	26
<u>SECTION 6: CLOSURES</u>	
CLOSURE UPPER RAIL AND CURB	27-30
CLOSURE LOWER RAIL	31
CLOSURE U-SHAPED	32
<u>SECTION 7: FINAL PLATFORM/RAMP STEPS AND CHECKS</u>	
SECURE RAMP TO PLATFORM	33
INSTALL RAMP HANDRAIL END LOOPS	34
INSTALL RAMP CORNER PROTECTORS	35
TOUCH-UP ARCHITECTURALLY FINISHED HANDRAILS	35
FINAL CHECKS	35
<u>SECTION 8: OPTIONAL EQUIPMENT</u>	
LANDING PAD	36
RAMP LOWER TRANSITION	37
<u>SECTION 9: MAINTENANCE & SAFETY</u>	
PERIODIC MAINTENANCE & SAFETY	38
<u>SECTION 10: DEICING</u>	38

1. CONFIGURATIONS

PATHWAY Aluminum Wheelchair Ramp Kits are available in three basic configurations: straight, L-shaped, and U-shaped, with two platform sizes available, 4' x 4' and 5' x 5'. All systems feature solid surface tread and two-line handrails.

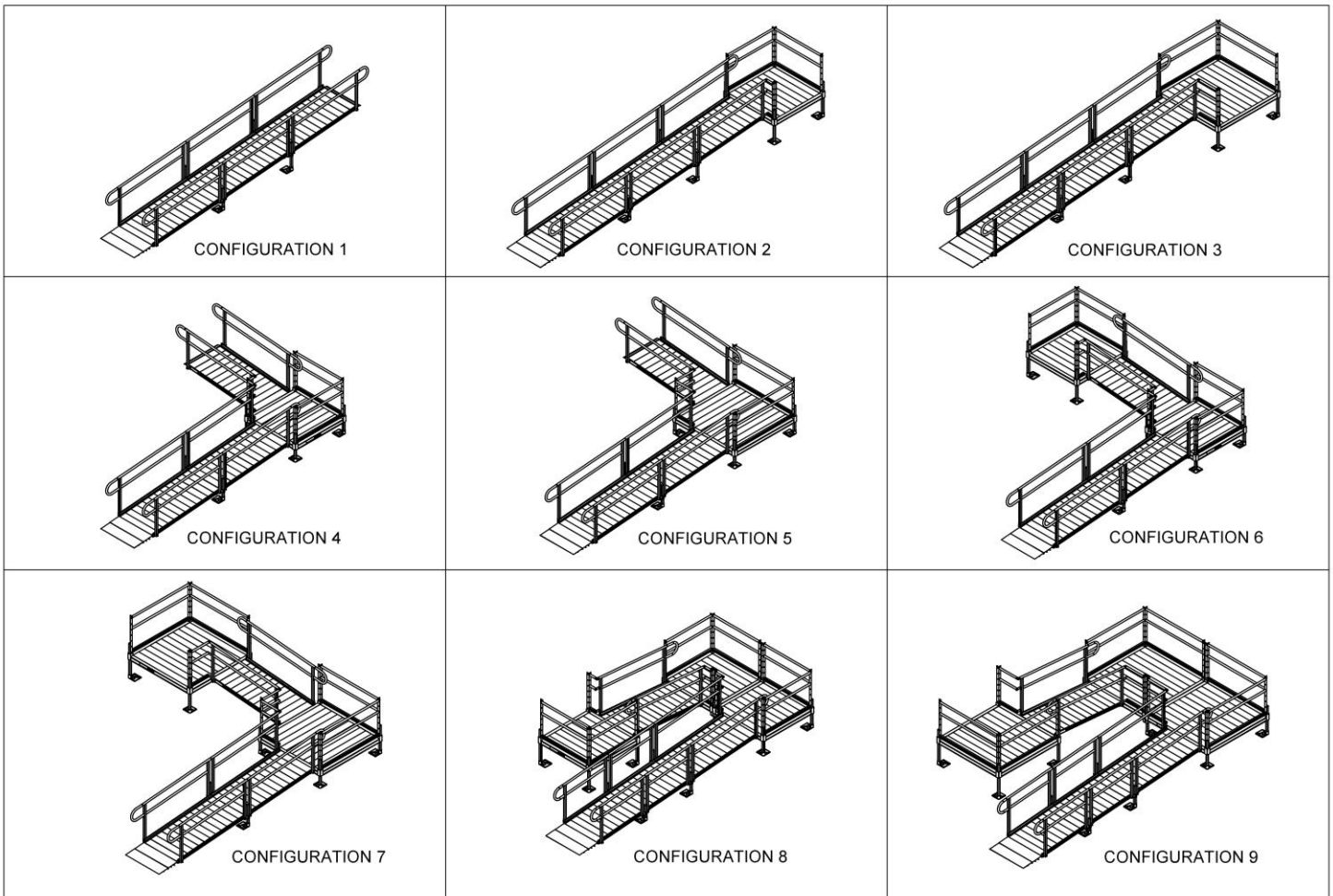

CONFIGURATION #	STYLE	AVAILABLE SIZES
CONFIGURATION 1	STRAIGHT	2' INCREMENTS RANGING FROM 10'-30' IN LENGTH
CONFIGURATION 2	STRAIGHT W/ 4' X 4' TOP PLATFORM	2' INCREMENTS RANGING FROM 10'-30' IN LENGTH
CONFIGURATION 3	STRAIGHT W/ 5' X 5' TOP PLATFORM	2' INCREMENTS RANGING FROM 10'-30' IN LENGTH
CONFIGURATION 4	L-SHAPED W/ 4' X 4' TURN PLATFORM	2' INCREMENTS RANGING FROM 10'-30' IN LENGTH
CONFIGURATION 5	L-SHAPED W/ 5' X 5' TURN PLATFORM	2' INCREMENTS RANGING FROM 10'-30' IN LENGTH
CONFIGURATION 6	L-SHAPED W/ 4' X 4' TURN AND TOP PLATFORM	2' INCREMENTS RANGING FROM 10'-30' IN LENGTH
CONFIGURATION 7	L-SHAPED W/ 5' X 5' TURN AND TOP PLATFORM	2' INCREMENTS RANGING FROM 10'-30' IN LENGTH
CONFIGURATION 8	U-SHAPED W/ 4' X 4' PLATFORMS	2' INCREMENTS RANGING FROM 20'-30' IN LENGTH
CONFIGURATION 9	U-SHAPED W/ 5' X 5' PLATFORMS	2' INCREMENTS RANGING FROM 20'-30' IN LENGTH

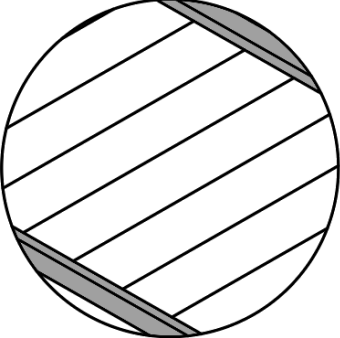
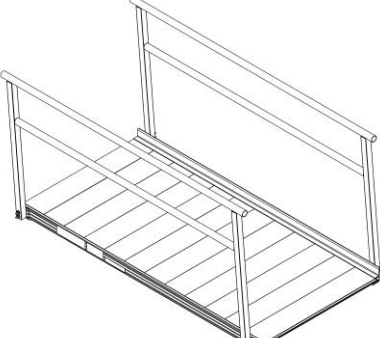

2. **BASIC SYSTEM COMPONENTS**

Because of varying lengths/configurations, your system may not contain all of these basic system components. Identify your system components before you begin installation.

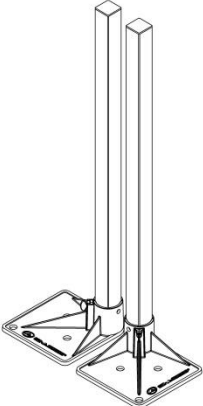
SURFACE OPTION	RAMP AND RAMP HANDRAIL OPTION
<p style="text-align: center;">SOLID SURFACE</p>	<p style="text-align: center;">RAMP W/ TWO-LINE HANDRAIL</p>
	

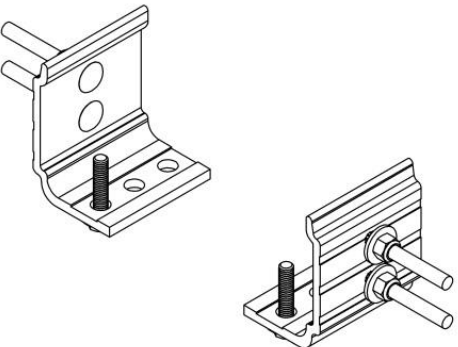
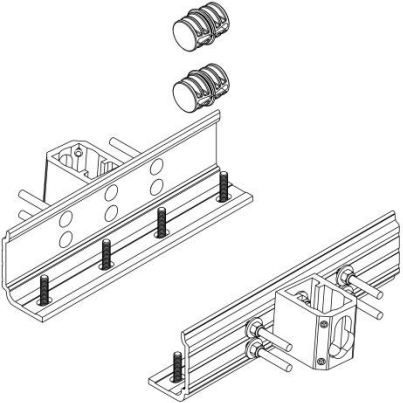
KEY RAMP COMPONENTS	
<p style="text-align: center;">PSLxxPR – SUPPORT LEG PAIRS (xx DENOTES USABLE LENGTH)</p>	<p style="text-align: center;">PRGT – RAMP GROUND TRANSITION 18" X 36"</p>
<p>INCLUDES BASE FEET</p> 	<p>SHOWN ASSEMBLED</p> 
<p style="text-align: center;">PRHBPR – RAMP HANDRAIL END BRACKET (PAIR)</p>	<p style="text-align: center;">PRRUC – UNIVERSAL CONNECTOR – RAMP TO RAMP</p>
	<p>INCLUDES COMPONENTS TO CONNECT RAMPS AND RAMP HANDRAILS</p> 

KEY RAMP COMPONENTS, CONT'D.

RAMP HANGER PAIR

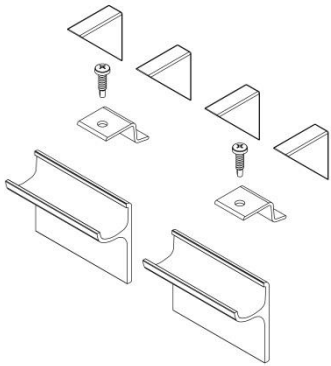

PRUT – RAMP UPPER TRANSITION

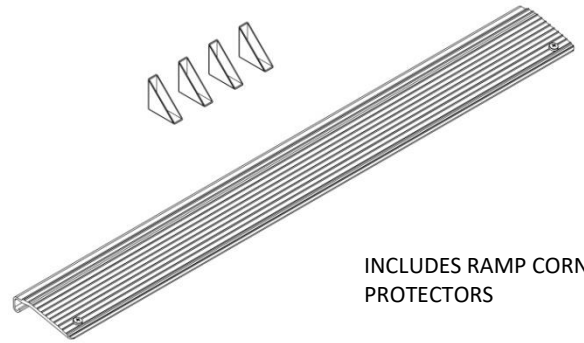

PRHRLU – UPPER HANDRAIL END LOOP

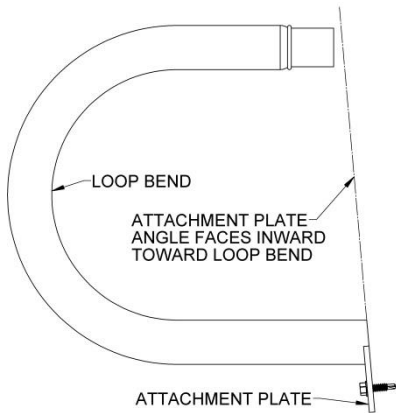

PRHRL – LOWER HANDRAIL END LOOP

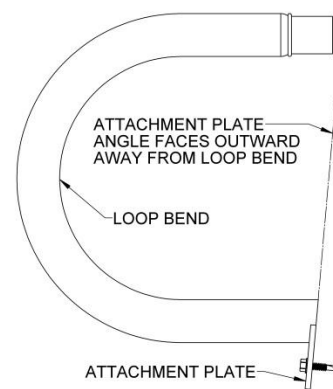

PUAB – ANGLE BRACE



PLATFORMS AND PLATFORM HANDRAILS

**PLATFORM (STRAIGHT CONFIGURATION)
W/TWO-LINE HANDRAILS**

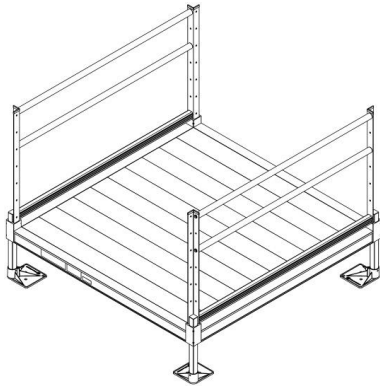

**PLATFORM (L-SHAPED CONFIGURATION)
W/TWO-LINE HANDRAILS**

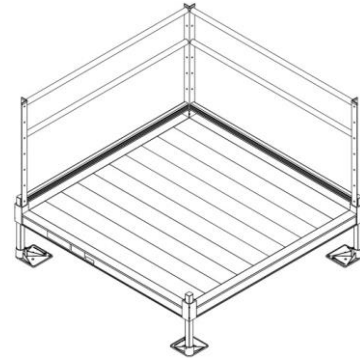

KEY PLATFORM COMPONENTS

PPPC – CONNECTOR – PLATFORM TO PLATFORM

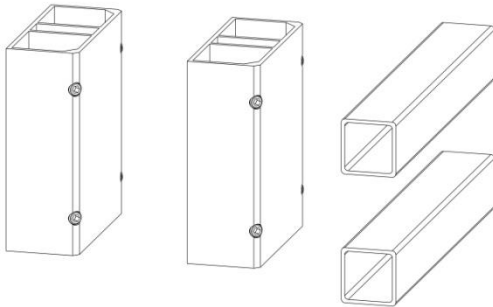

PBP36 – BRIDGE PLATE

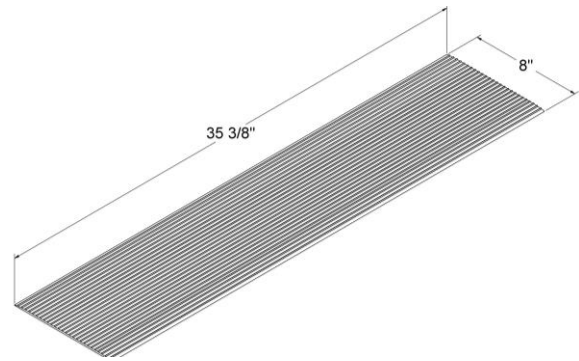

CLOSURE OPTION

PPCTL – TWO-LINE HANDRAIL CLOSURE

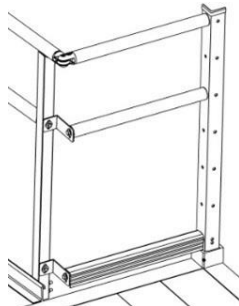

PTBCTL – TWO-LINE HANDRAIL CLOSURE U-SHAPED

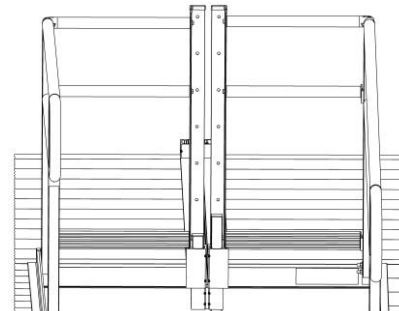

ADDITIONAL OPTIONS

PLP – LANDING PAD

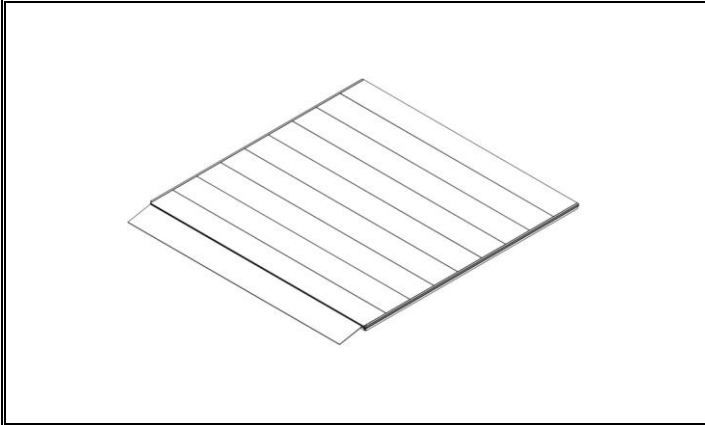

PRLT – RAMP LOWER TRANSITION

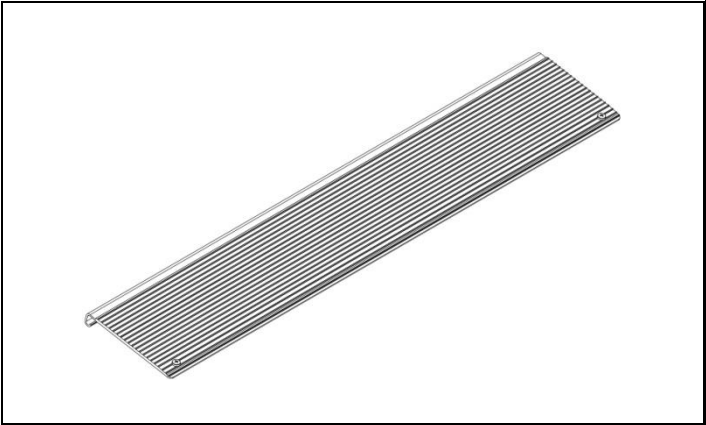

3. **PLATFORMS**

3.1. INSTALL PLATFORMS

- ✎ If your configuration does not include a platform, skip to 'CONNECT RAMP SECTIONS'.
- ✎ Platform handrails are shown for clarity of how to orient platforms in various configurations. It is strongly suggested that all platforms and ramps be installed before installing handrails (see 'HANDRAILS').

3.1.1. There are three basic platform arrangements (one or more of these arrangements may be used in an installation). All require the same procedure for assembly except for FIG.2.3 which requires an additional PPPC (PLATFORM TO PLATFORM CONNECTOR).

FIG. 3.1 Straight

FIG. 3.2 L-shaped

FIG. 3.3 U-shaped

✎ Two 5' x 5' platforms shown combined to make a 5' x 10' U-shaped.

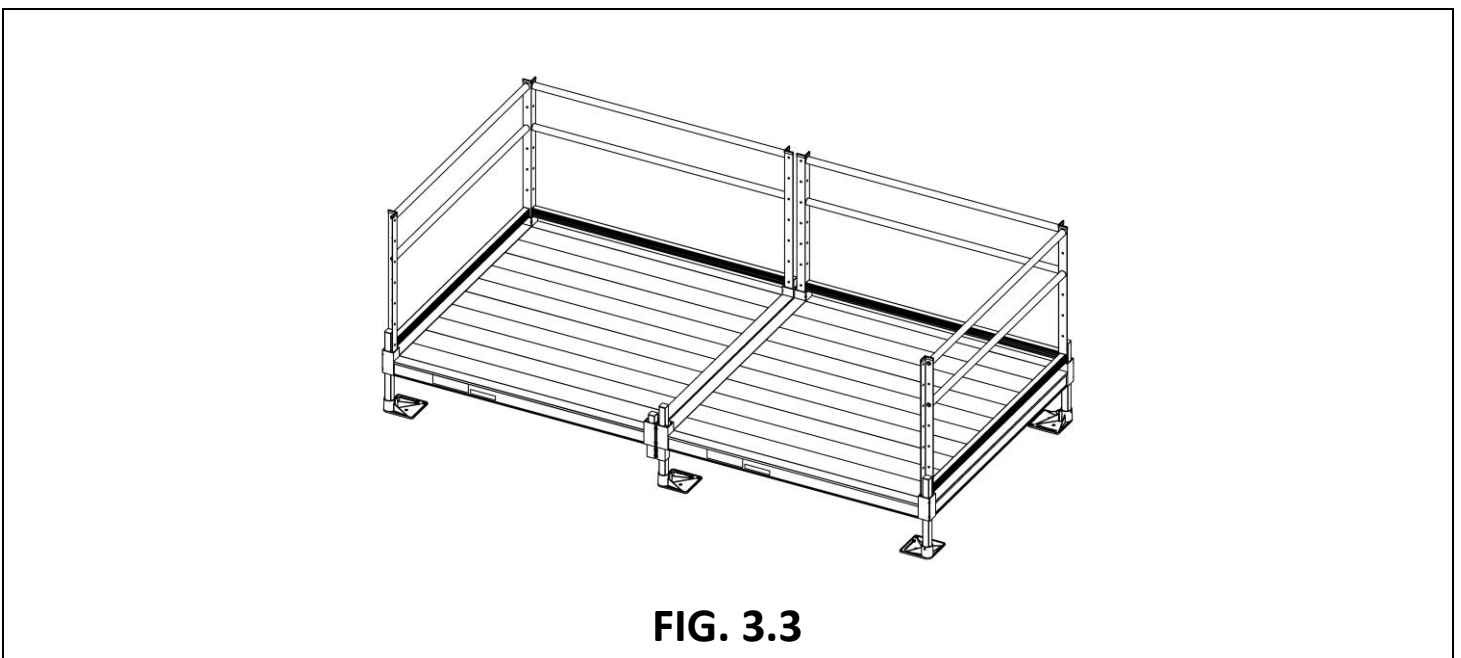
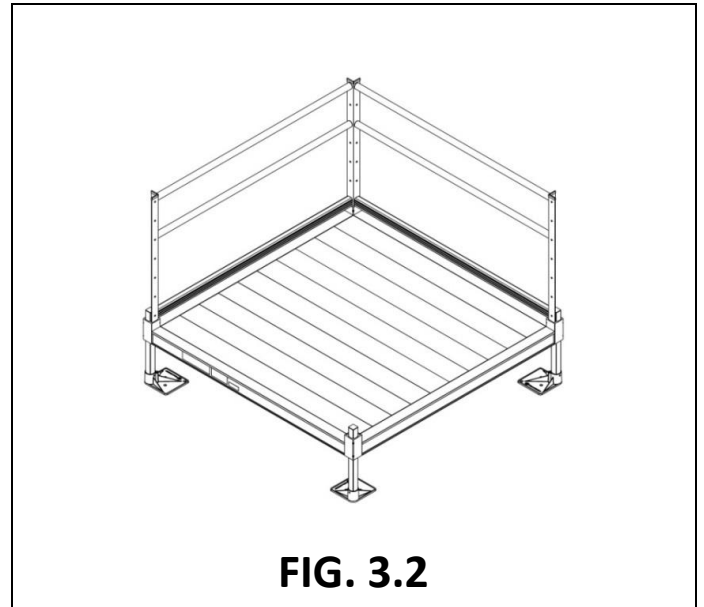
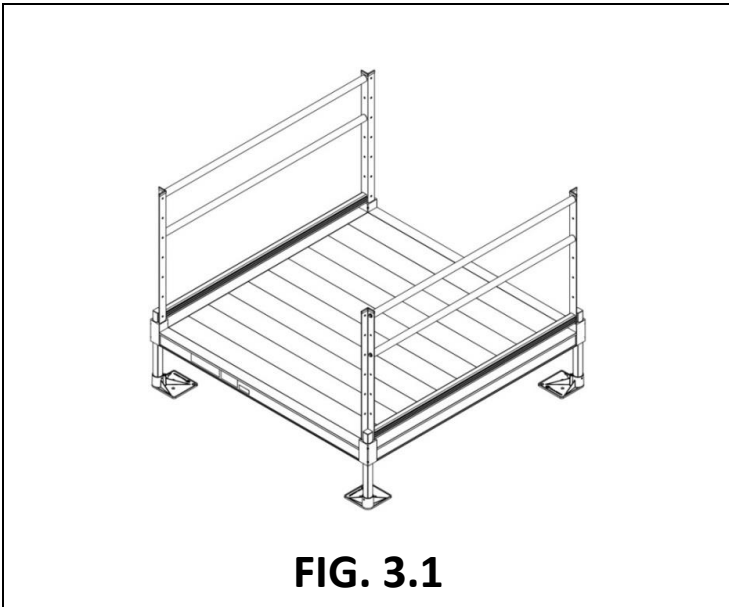

3.2. INSTALL SUPPORT TUBES AND FEET, THEN ADJUST PLATFORM HEIGHT

- 3.2.1. Support tubes, plugs, and feet come in pairs. Support tubes will come in lengths sufficient to accommodate a range of slope options.
 - ⚠ ADA guidelines call for a maximum slope of 1:12 (approximately 5-degrees) and this is the ideal slope for the system. However, the ramps can be installed from 1:14 to 1:8 (approximately 4- to 7-degrees). Do not attempt to install the ramps outside this range.
- 3.2.2. Loosen all set screws in the platform corner pockets.
 - 3.2.2.1 The set screws on the outside of the platform are for the platform support tubes.
 - 3.2.2.2 The set screws on the inside of the platform (one above the deck and one below the deck) are for the handrail posts.
- 3.2.3. Tip the platform on its side, then slide the support tubes into the four platform corner pockets (FIG.3.4). Adjust the support tubes to the approximate platform height needed.
- 3.2.4. Use a 3/16" Allen wrench to tighten the upper of the two set screws in the corner pocket, just enough to hold the support tube in place but do not over tighten (the second set screw will be tightened after final height adjustments are complete).
 - 👉 Platforms configured in a U-shape (FIG. 3.3) will have six tubes to adjust.
 - ⚠ Do not attempt to walk on the platform until all support tube set screws have been tightened securely.
- 3.2.5. Place the platform (with support tubes attached) into the upright position.
 - ⚠ Do not let the weight of the platform bear on the support tubes while tipping the platform upright.

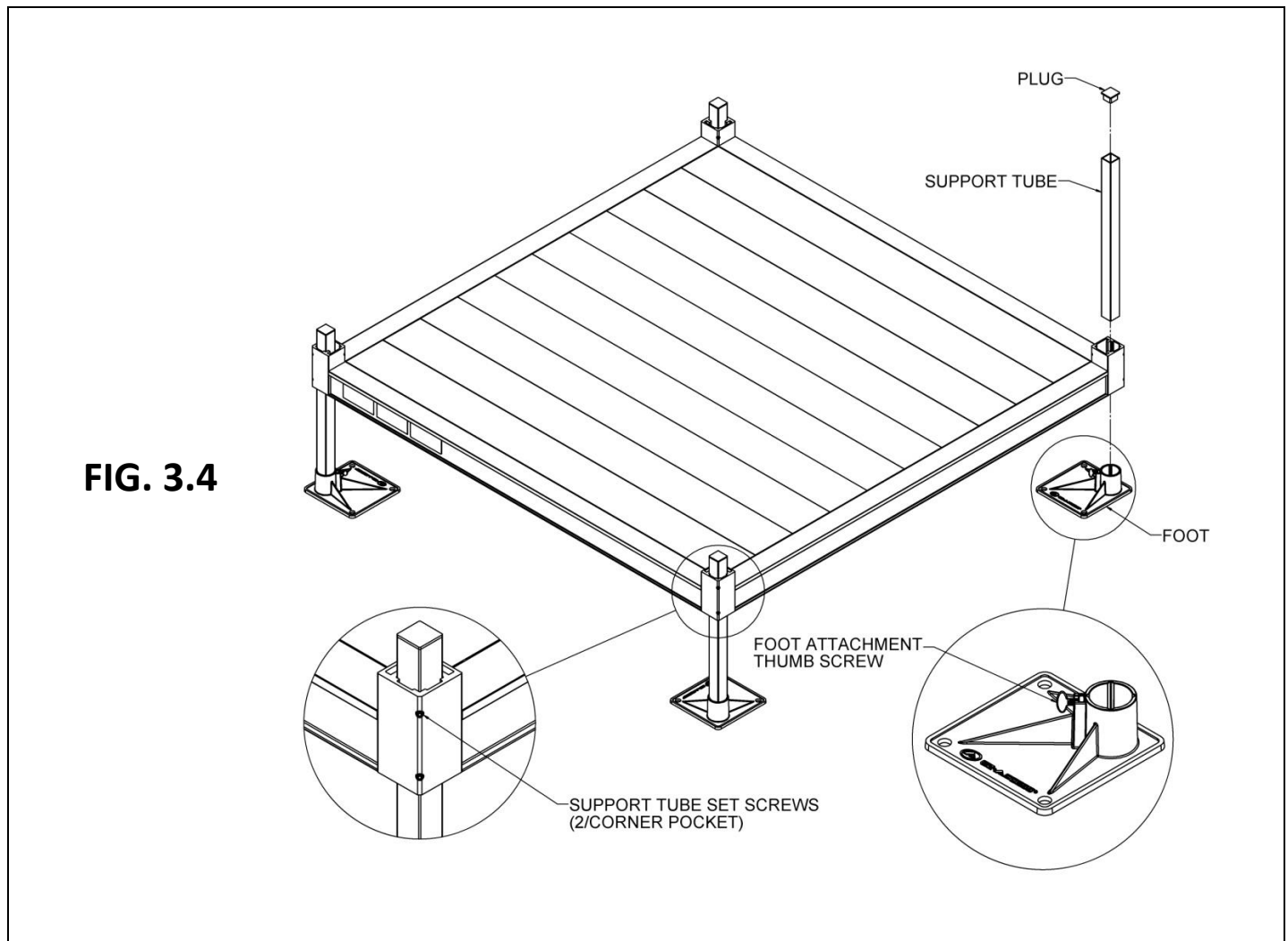

- 3.2.6. Lift each corner of the platform and install a Base Foot (foot) on each support tube oriented so that the foot extends under the platform (FIG. 3.4).
 - ✎ The feet can be oriented in other directions if necessary due to site conditions but may present a tripping hazard if not oriented under the platform.
 - ⚠ It is the installer's responsibility to install the system in a manner which is safe for the persons on and around the system and clearly mark any hazards created by the installation.
 - 3.2.7. Make sure each foot is fully engaged on the tube and tighten the thumb screw securely.
 - ✎ If installing on soft soil it may be necessary to set the foot on a concrete pad.
 - 3.2.8. Adjust the final height of the platform by adjusting legs, one at a time, by loosening the outer set screws in the platform corner pockets. Using a level, adjust the platform height and re-tighten.
 - 3.2.9. Once the final height has been adjusted, tighten the second, lower set screw in each platform corner pocket.
 - 3.2.10. To allow access to the lowermost hole in the platform post, the support tubes must not extend more than 1/2" above the platform corner pockets. Trim the support tubes as needed before installing plugs.
 - 3.2.11. Insert a plug into the top of each support tube. Use a rubber mallet or similar tool as needed (FIG. 3.4).
 - 3.2.12. Ensure all set screws are tightened securely.
- 3.3. CONNECT TWO PLATFORMS TOGETHER (U-SHAPED CONFIGURATIONS ONLY)
- ✎ If your system does not include a U-shaped configuration but does include a platform, skip to 'INSTALL UNIVERSAL ANGLE BRACE – PLATFORMS'.
 - 3.3.1. Assemble the first platform as described in the previous steps except on the side where the second platform will connect, install two PPC (CONNECTOR – PLATFORM TO PLATFORM) before installing feet onto the support tubes.
 - 3.3.2. Make sure the platform connector set screws are oriented outward so they will be accessible.
 - ✎ Any two platforms of the same width can be connected.
 - 3.3.3. Slide the platform connectors up until they contact the bottom of the platform and tighten the set screws securely (FIG. 3.5).
 - 3.3.4. Install a support tube stub into the open pocket in each connector until the bottom of the stub is flush with the bottom of the connector and tighten the set screws securely.
 - 3.3.5. Install a plug in the top of each support tube stub (FIG. 3.5).
 - 3.3.6. Assemble the second platform as described in the previous section except only install support tubes, plugs, and feet on the opposite side of where the platforms will connect (FIG. 3.6).
 - 3.3.7. Lift the second platform and slide the open corner pockets over the support tube stubs extending up from the platform connectors. Tighten the set screws in the platform corner pockets securely.
 - 3.3.8. Adjust the platform heights and level as needed.
 - ⚠ Make sure all the set screws in both the platform corner pockets and the platform connectors are tightened securely before proceeding with the installation.

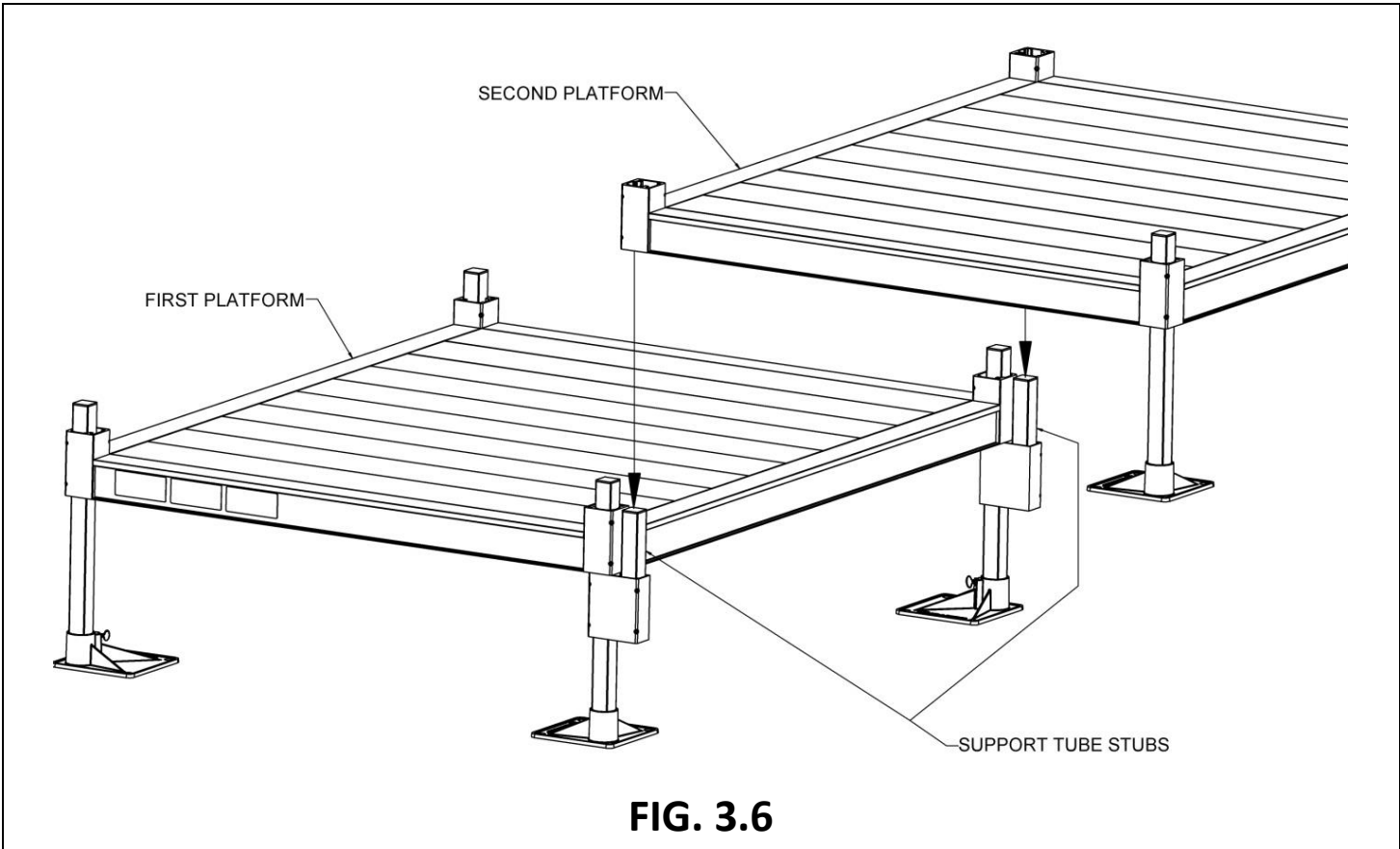
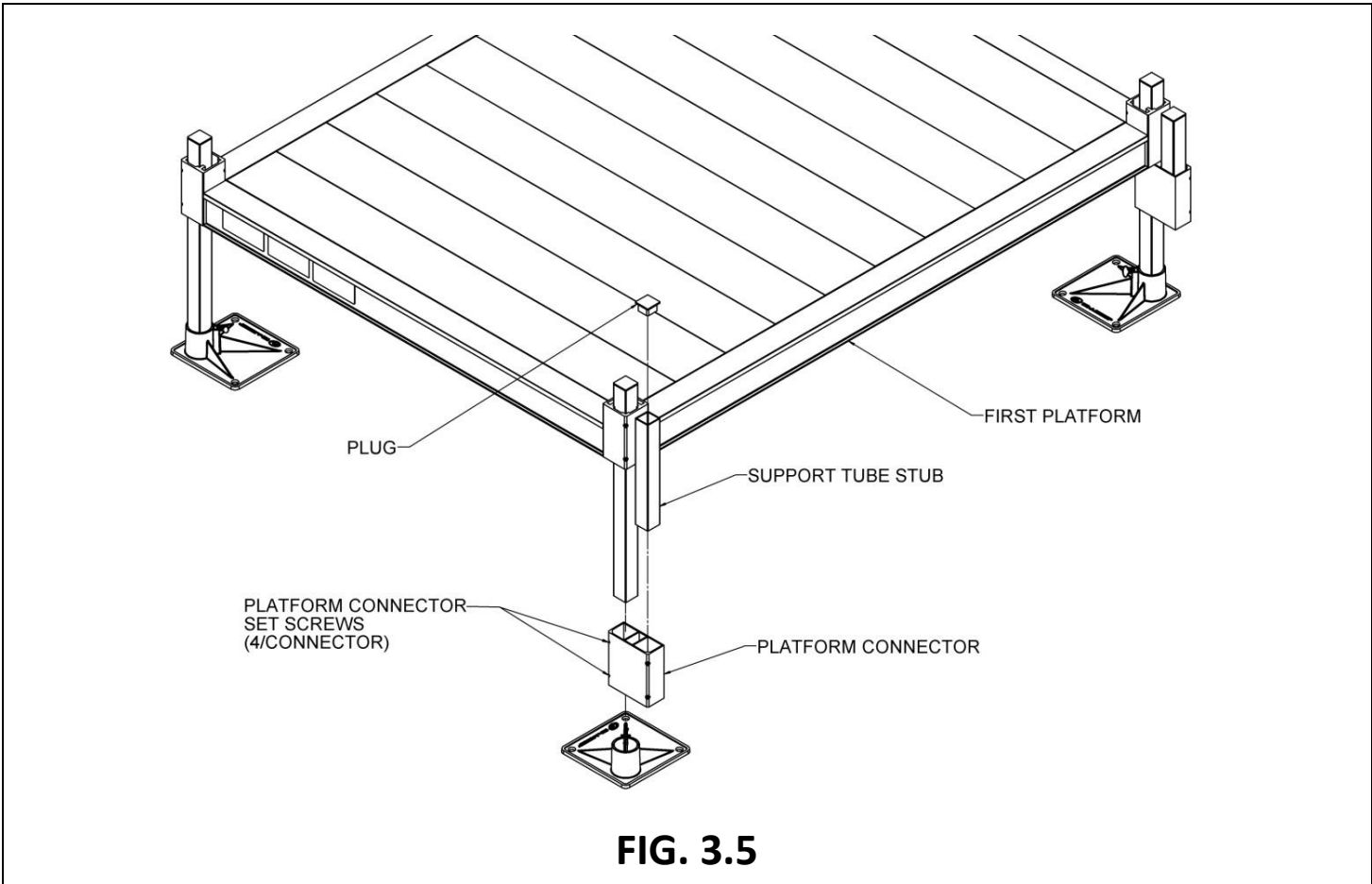

3.4. INSTALL UNIVERSAL ANGLE BRACE – PLATFORMS

✎ For added stability, any platform with a walking surface over 36" high requires bracing. The PUAB (PATHWAY ANGLE BRACE) is used for all surfaces 36" elevation and over.

- 3.4.1. Angle braces come in pairs. Use four pairs per platform (one pair per support tube, or side) or six pairs when two platforms are connected.
- 3.4.2. Use two brace bands to secure the ends of the two angle braces nearest the twist to the support tube using a 5/16" bolt, flat washer, and nut (FIG. 3.7).
- 3.4.3. Opposite ends of the braces are attached to the bottom of the platform side rail at 90-degrees to each other using a 1/4" x 1" long self-drilling screw (FIG. 3.7).

⚠ Ensure that all angle braces are secured before using platform.

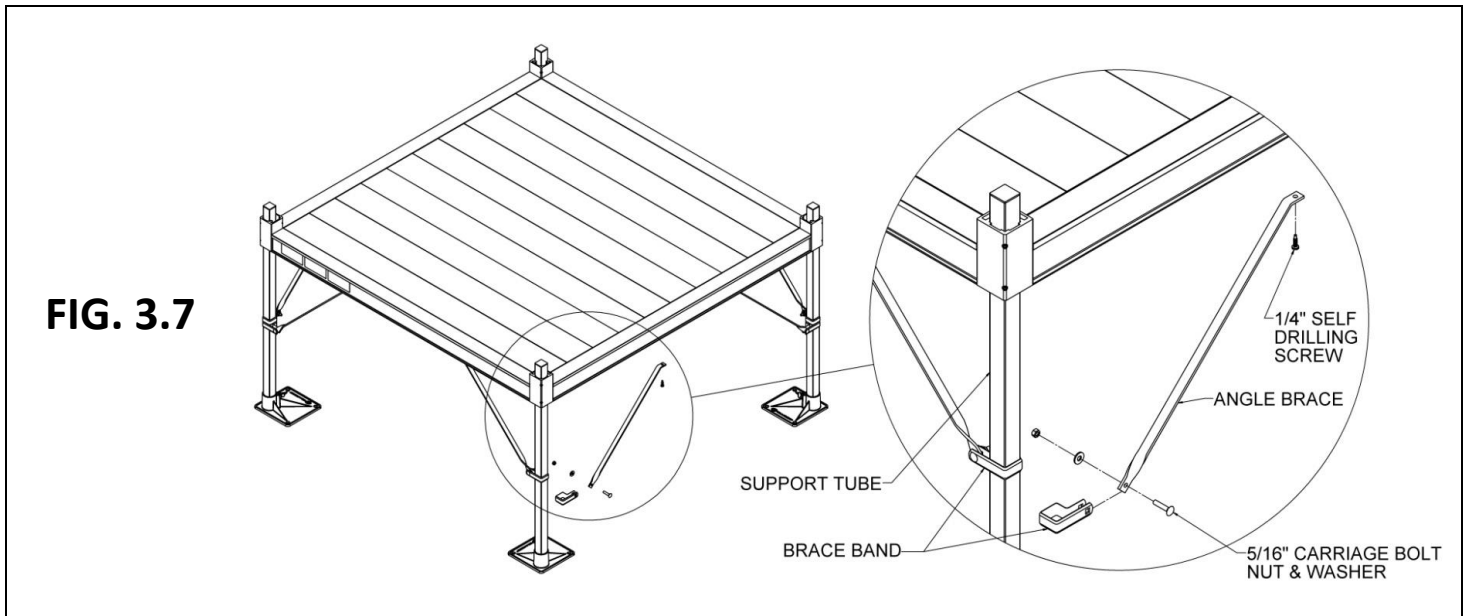

4. RAMPS

4.1. CONNECT RAMP SECTIONS

- ✎ If your configuration does not contain two or more consecutive ramps, skip to 'INSTALL A SINGLE RAMP RUN TO AN EXISTING STRUCTURE'.
- 4.1.1. Place the walking surface side of the ramp sections face down, onto cardboard or lawn so that the ramp is not damaged (scratched or dented).
- 4.1.2. Butt the sections together end-to-end and ensure there is no gap, then position the two center saddle brackets, included in the PRC (CONNECTOR – RAMP TO RAMP), over the threaded inserts at the end of each ramp section (FIG. 4.1).
- 4.1.3. One edge of the center saddle bracket will slide into the groove of the ramp sections.
 - ✎ To create a run, ramp sections are connected using two interchangeable center saddle brackets per joint. The center saddle brackets are also where the handrails and ramp legs are attached.
- 4.1.4. Attach the center saddle brackets using four each 5/16"-18 x 1-1/2" bolts and 5/16" washers per bracket. Tighten all eight bolts (four each per center saddle bracket).
 - ✎ Although a system can have multiple ramps per run, it is recommended that a maximum of three ramp sections at a time be joined in this manner.
- 4.1.5. Install four end brackets, PRHBPR (RAMP HANDRAIL END BRACKET PAIR). These will be used to attach handrails in a later step. Use one end bracket at each outside corner of the ramp or ramp run using one 5/16" x 1-1/2" bolt and washer into the threaded insert closest to the end of the ramp (FIG. 4.2).
- 4.1.6. Turn the joined ramps to their upright position, being careful not to damage the threaded studs.

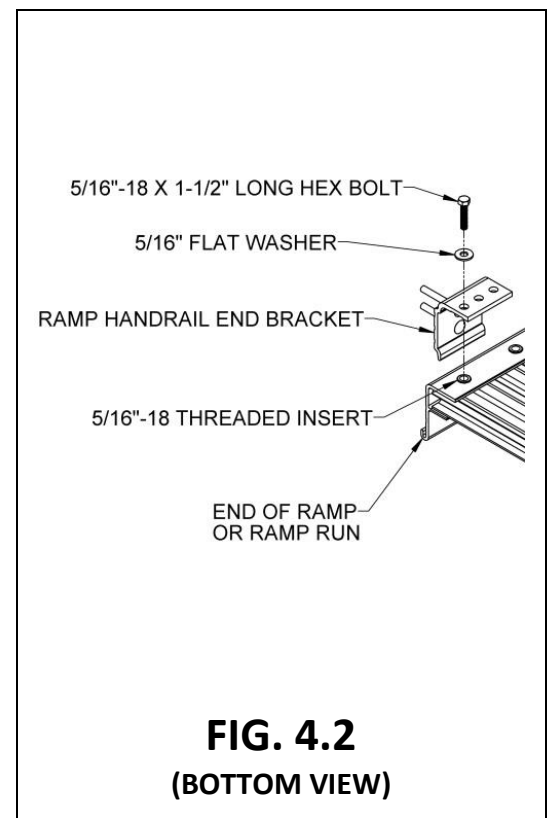
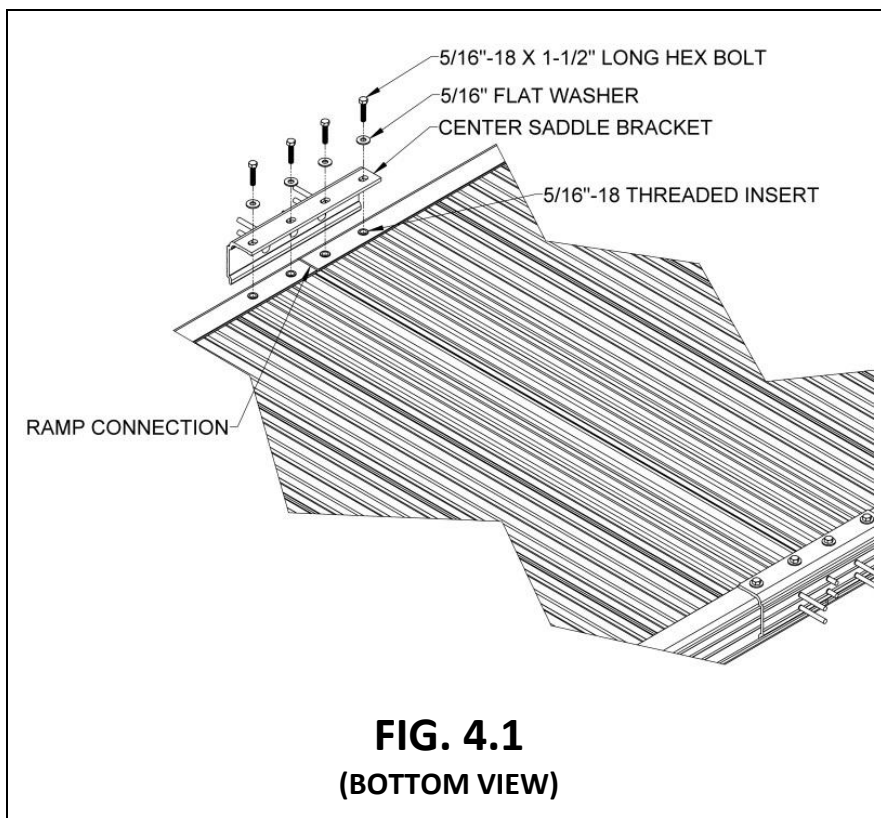

4.2. INSTALL RAMPS ON PLATFORMS

- ✎ If your configuration does not include a platform, skip to 'ATTACH SUPPORT LEG BRACKETS AND LEGS TO RAMPS'.
- ✎ This section addresses the attachment of a ramp or ramp run to a platform. If the ramp needs to be angled with respect to the platform or is going to be attached to an existing porch, skip to 'ANGLE RAMPS WITH RESPECT TO PLATFORMS, PORCHES, OR DECKS'.

4.2.1. Ramps must be placed on either the left or right side of the platform (cannot be centered).

4.2.1.1. Place the ramp in a location that ensures the ramp handrail post is positioned 1-1/2" (minimum) to 2" from the inside of the platform post.

4.2.2. Locate the PRHP (RAMP HANGER PAIR) and install the two hangers in the platform side rail where the ramp will be attached.

4.2.3. Hold the hanger perpendicular (approximately) to the platform side rail then bring the hanger upward until it is against the side rail lip. Rotate the hanger and continue pushing upward in such a manner that the "hook" at the top of the hanger goes behind and catches on the lip in the top of the platform side rail and the hanger sits on the ledge at the bottom (FIG. 4.3).

4.2.4. Set the ramp on the hangers. The hangers should be positioned as close as possible to the ramp side rails. The procedure is the same at both the top and bottom of ramp runs which end at a platform unless a transition plate is used (FIG. 4.4).

⚠ Do not attempt to walk on the system until installation is complete.

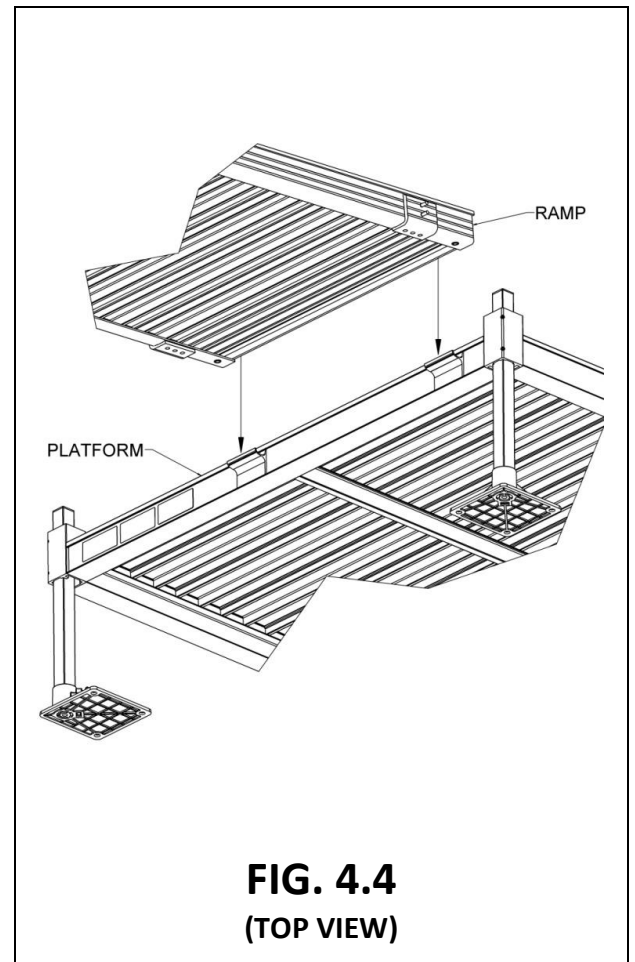
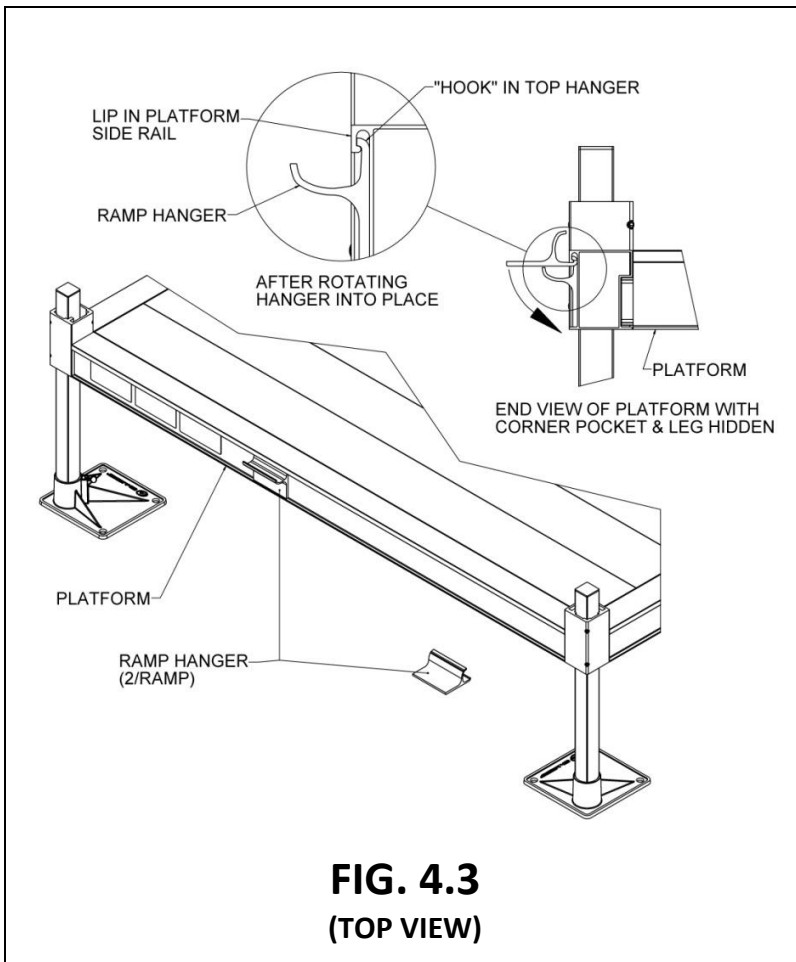

4.3. ATTACH SUPPORT LEG BRACKETS AND LEGS TO RAMPS

- 4.3.1. Install the Support Leg Bracket (bracket), included with PRRUC, onto the center studs of the Center Saddle Bracket (ramp connector included with PRRUC) with the round hole on the upper stud and the curved slot over the lower stud (FIG. 4.5).
- 4.3.2. Attach the bracket using the provided 5/16" flat washers and 5/16"-18 nylon insert locknuts onto the studs but do not tighten fully until the bracket has been leveled.

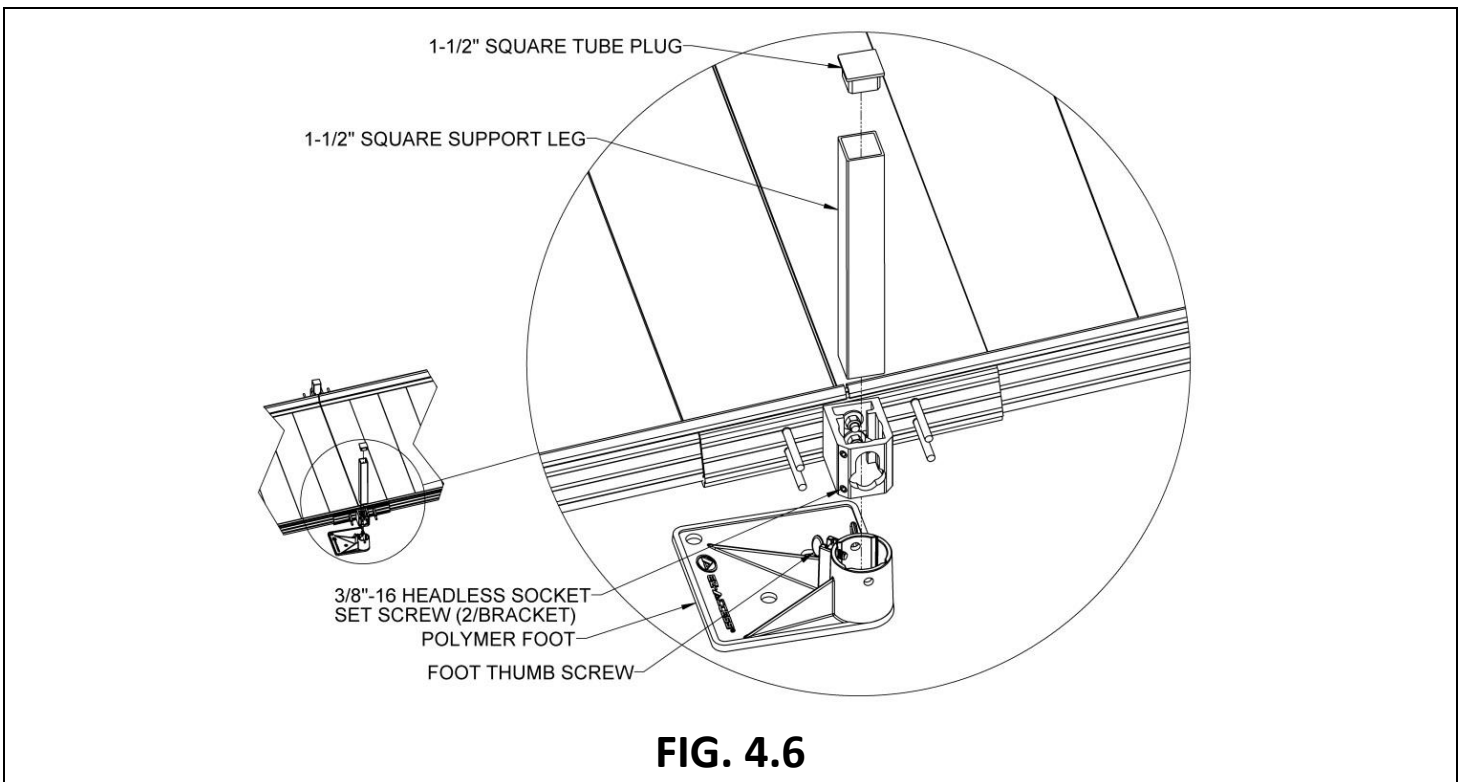
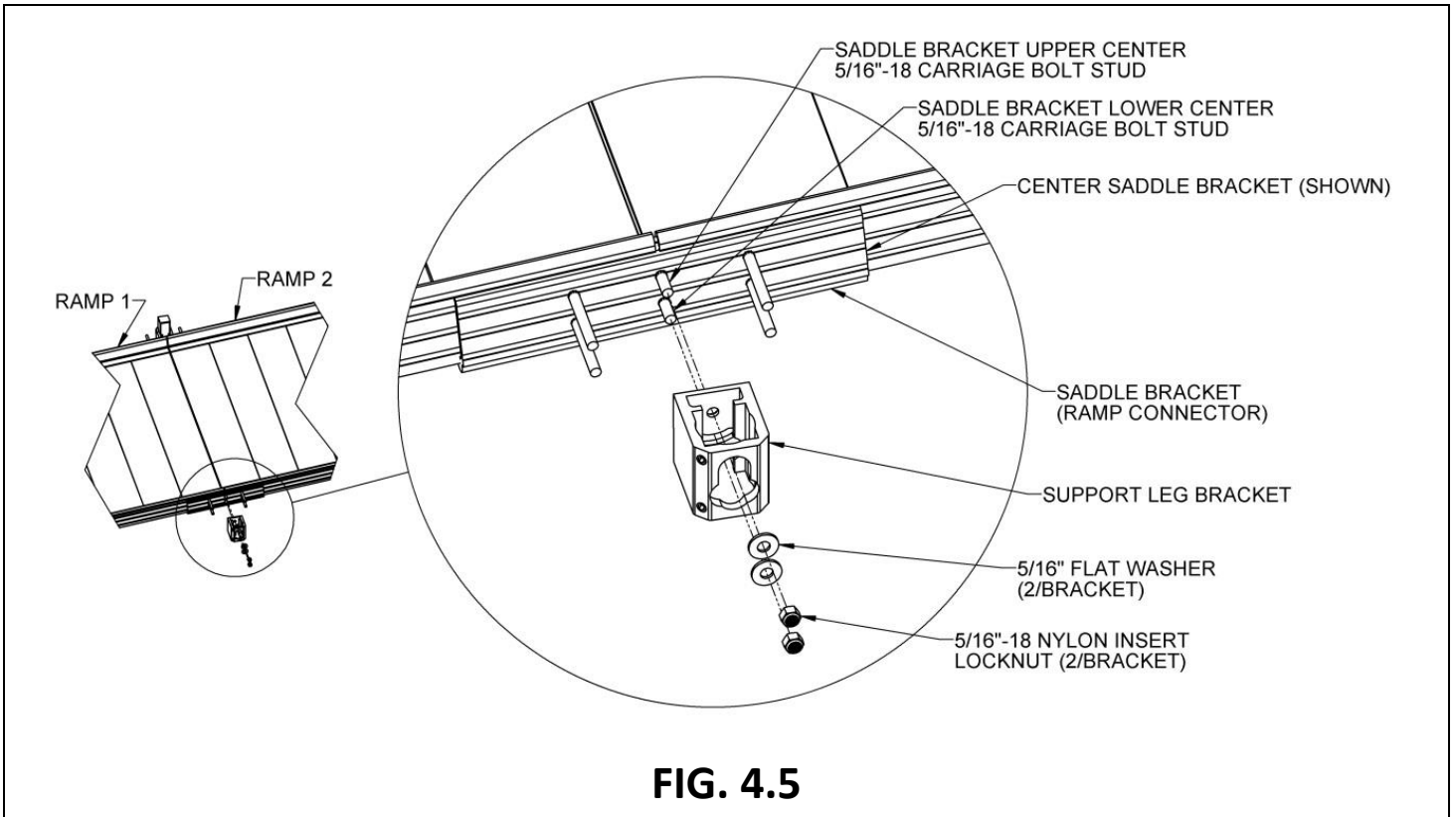

- 4.3.3. Level the bracket using a bubble level or similar tool, then torque the 5/16"-18 nylon insert locknuts to 20 ft.-lbs.
- 4.3.4. Locate the appropriate PRLxxPR (SUPPORT LEG PAIR where "xx" denotes the leg length) for the location. Place a foot under the bracket with the foot extending under the ramp, then insert a 1-1/2" square Support Leg (leg) through the bracket into the foot. Loosen the 3/8"-16 headless socket set screws and the foot thumb screw if needed to fully engage the leg in the foot (FIG. 4.6).
 🖐 If installing on soft soil it may be necessary to set the foot on a concrete pad.
- 4.3.5. After the leg is fully engaged in the foot, tighten the 3/8"-16 headless socket set screws to 15 ft.-lbs. (FIG 4.6).
 ⚠ Do not attempt to walk on the ramps until all leg set screws have been tightened as specified.
- 4.3.6. Tighten the foot thumb screw and insert 1-1/2" square plug into the top of the leg (FIG. 4.6).
- 4.3.7. Repeat the above procedure at all locations where ramps connect.
- 4.3.8. Adjust the legs one at a time.
- 4.3.9. Raise the ramp sections (at the center saddle bracket) to take any sag out of the ramp run, then tighten the two locknuts in each leg.
 ⚠ ADA guidelines call for a maximum slope of 1:12 (approximately 5-degrees) and this is the ideal slope for the system. However, the ramps can be installed from 1:14 to 1:8 (approximately 4- to 7-degrees). Do not attempt to install the ramps outside this range.
 🖐 Adjusting sections can be accomplished by having someone sight down the ramp while another person adjusts the ramp height.
 🖐 Ensure that the ramp sections are parallel to each other. If they are not, it may be difficult to install the handrails (FIG. 4.7).
- 4.3.10. Insert a plug into the top of each leg (FIG. 4.6).
- 4.3.11. Ensure that all bolts are tight and that the ramp sections are aligned parallel to one another.

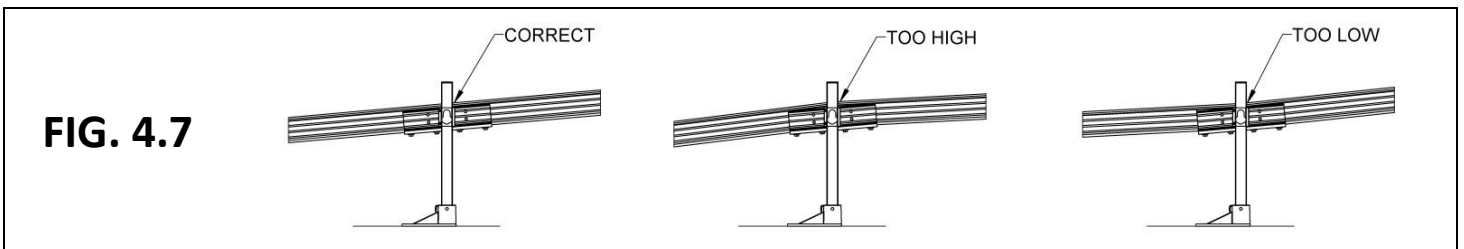

4.4. INSTALL UNIVERSAL ANGLE BRACE – RAMPS

⚠ If the walking surface is over 36" high, a PUAB (UNIVERSAL ANGLE BRACE) must be installed under the ramp (FIG. 4.8).

4.4.1. Angle Braces (braces) come in pairs; use one pair per ramp connection.

4.4.2. The brace bands are installed on ramp legs in the same manner as platform legs (refer to 'INSTALL UNIVERSAL ANGLE BRACE – PLATFORMS').

4.4.3. The opposite end of the brace is attached to the bottom of the ramp (near the center of the tread at the end of the ramp) using a 1/4" x 1" long self-drilling screw.

⚠ Ensure that all braces are secured before using the ramp.

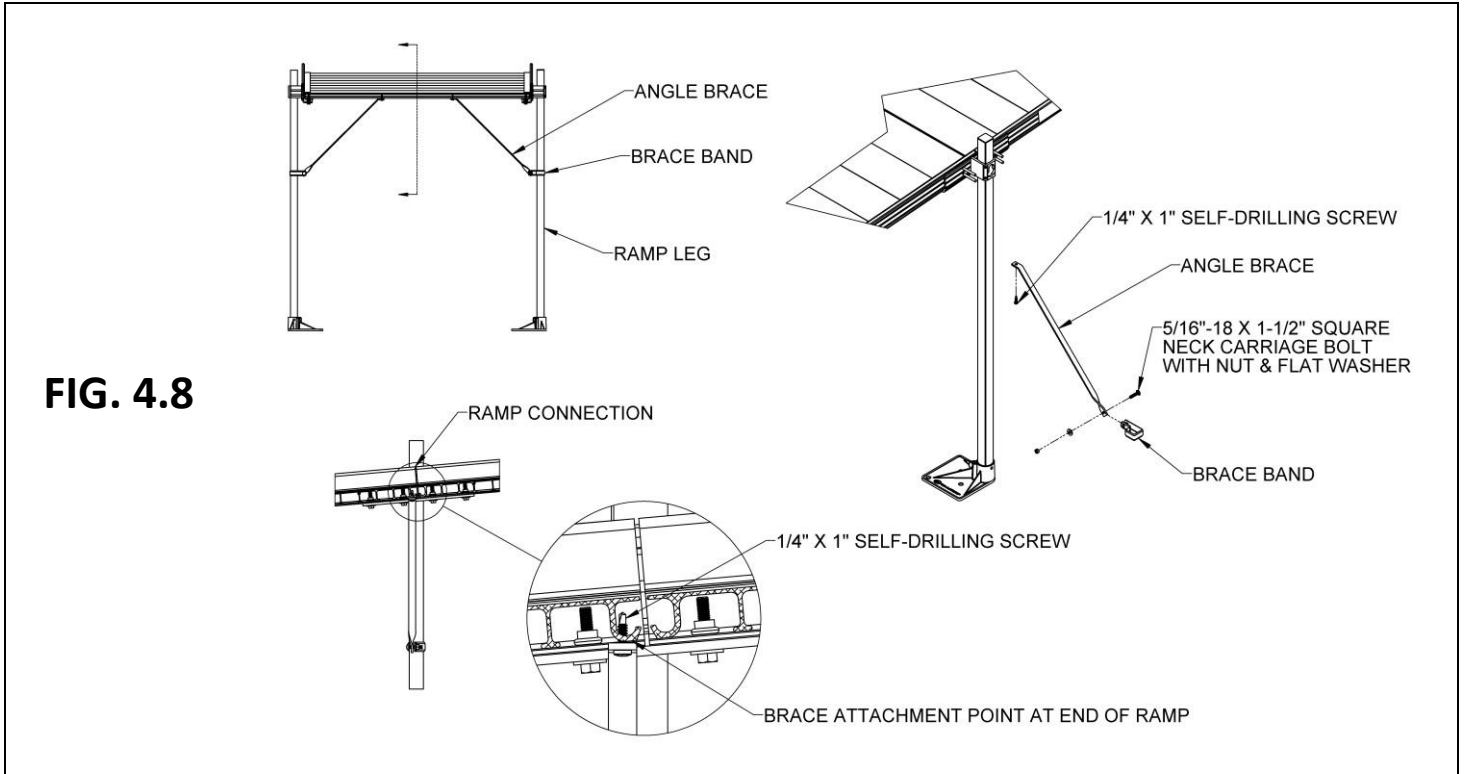

4.5. INSTALL RAMP GROUND TRANSITION

4.5.1. The PRGT (RAMP GROUND TRANSITION) consists of two sections that need to be installed into the ramp and connected together.

⚠ The Ramp Ground Transition is only designed to transition from the lowest ramp in the run to the ground; do NOT USE in any other location.

4.5.2. Lift the lowest end of the ramp/ramp run and bring the upper section of the Ramp Ground Transition into the ramp end tread until the "hook" is engaged (FIG. 4.9).

4.5.3. Rotate into place (FIG. 4.10) and set back on the ground.

4.5.4. Slide the lower section into upper section (FIG. 4.11).

4.5.5. Install #8-32 x 1/2" hex washer head thread cutting screws into the screw slots on both sides where the sections connect (FIG. 4.12).

✋ The hex washer head screws will keep the sections from sliding with respect to each other, but the sections can still be separated until they are installed in the ramp and resting on the ground.

4.5.6. Holes and fasteners are included for anchoring into wood or concrete. Other methods may be used when anchoring into other surfaces.

4.5.7. If connecting the lowest end of the ramp to a PLP (LANDING PAD), use a PRLT (RAMP LOWER TRANSITION), which is included with the landing pad, instead of a PRGT (RAMP GROUND TRANSITION). Please see 'OPTIONAL EQUIPMENT' for instructions.

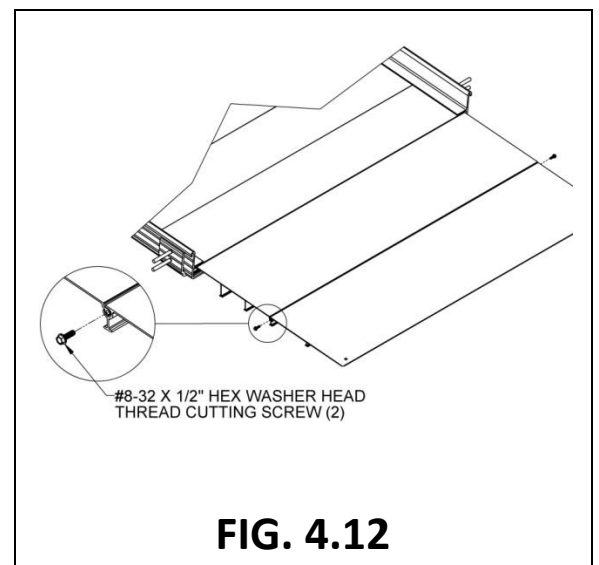
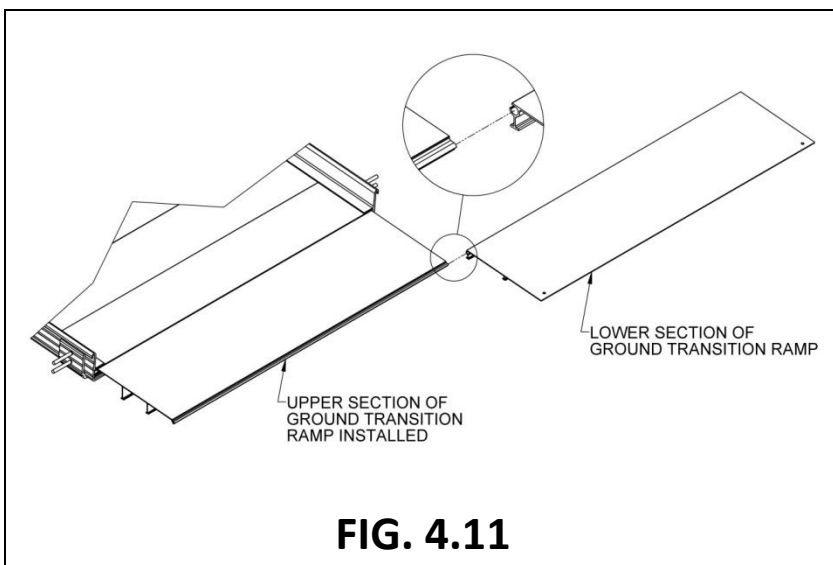
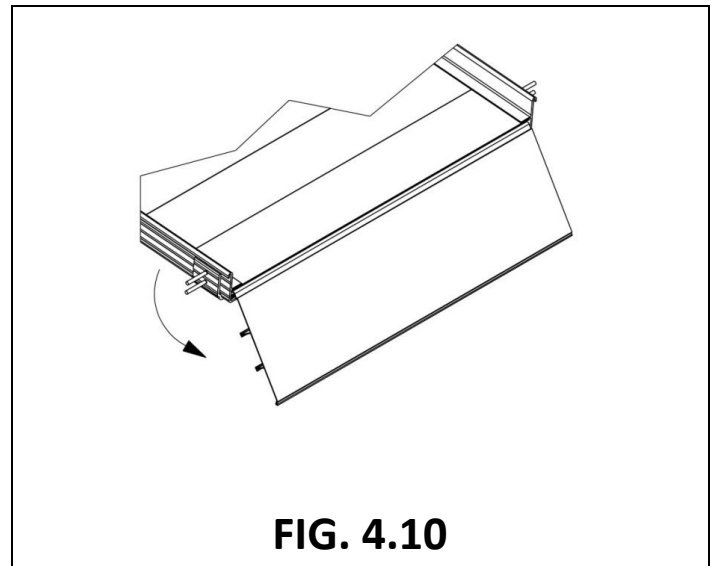
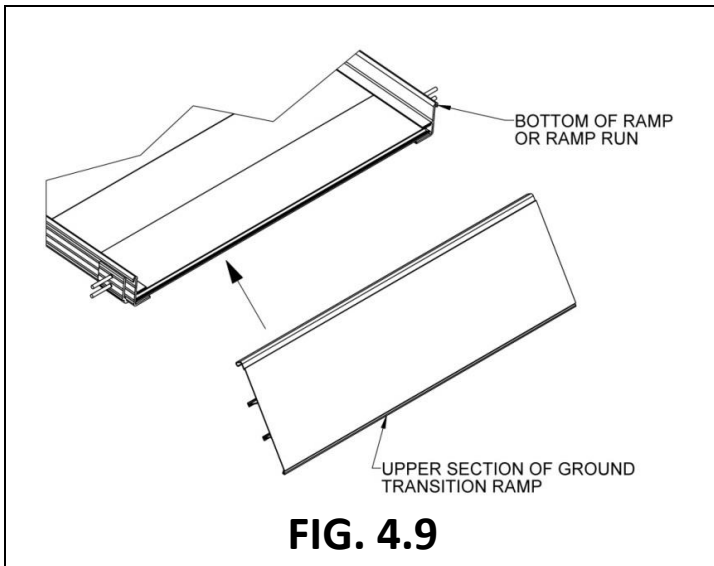

4.6. INSTALL A SINGLE RAMP RUN TO AN EXISTING STRUCTURE

- 🖐 This section (as well as 4.7 & 4.8) addresses configurations that do not include a top platform (the ramp run will be connected to an existing landing, such as a porch, deck, stairs, etc.).
- 4.6.1. Turn the ramp section upside down on a flat surface. Do this on cardboard or a lawn so that the ramp is not damaged (scratched or dented).
 - 4.6.2. Locate PRHBPR (RAMP HANDRAIL END BRACKET PAIR). Install four end brackets (will be used to attach handrails in a later step). Install one end bracket at each outside corner of the ramp section using one 5/16" x 1-1/2" bolt and washer into the threaded insert closest to the end of the ramp (FIG. 4.13).
 - 4.6.3. Turn the ramp over to the upright position.
 - 4.6.4. Place the upper end of the ramp onto supporting surface, i.e., platform, porch, etc. Once the ramp is resting on the porch or platform, lift the upper end of the ramp and install the PRUT (RAMP UPPER TRANSITION) into what will be the upper end of the ramp (FIG. 4.14) and the PRGT (RAMP GROUND TRANSITION) into what will be the lower end of the ramp.
 - 4.6.5. Maneuver the ramp to its desired position (FIG. 4.15).

FIG. 4.13

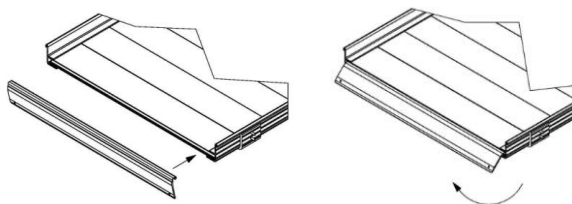
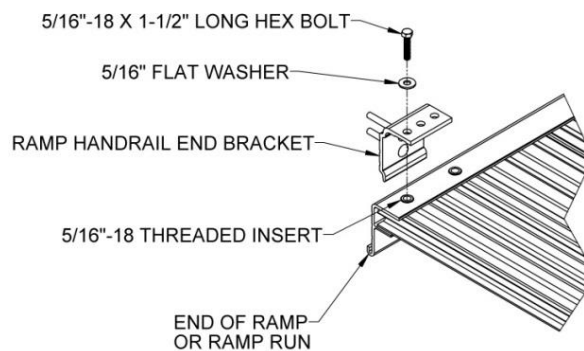

FIG. 4.14

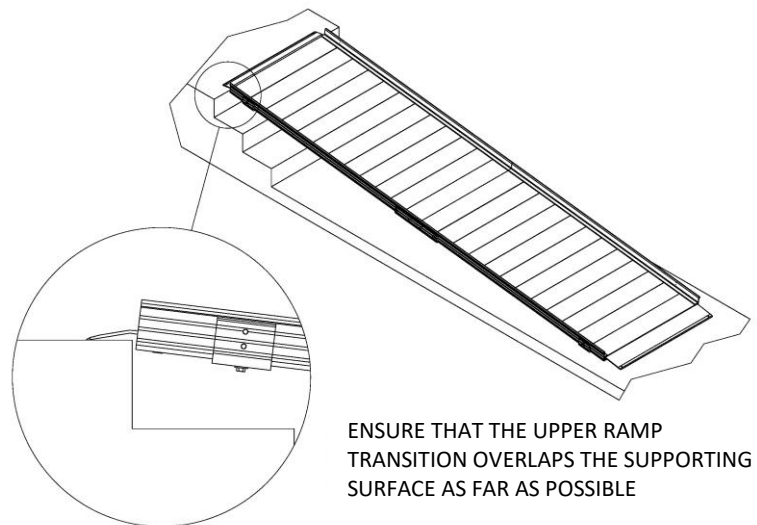

FIG. 4.15

4.7. ANCHOR RAMP UPPER TRANSITION

- ▲ The PRUT (RAMP UPPER TRANSITION) must be anchored to a substantial surface. Use the pre-drilled holes at each corner of the Ramp Upper Transition as guides.

4.7.1. IF RESTING ON A WOOD SURFACE:

- 4.7.1.1. Secure Ramp Upper Transition by installing the 1/4" x 1" long self-drilling screw through each hole (FIG. 4.16).

4.7.2. IF RESTING ON A CONCRETE SURFACE:

- 4.7.2.1. Using the Ramp Upper Transition as a template, transfer the hole locations to the concrete surface and note locations with marking device.
- 4.7.2.2. Remove Ramp Upper Transition. Using a 1/4" masonry bit, drill two 1-1/2" deep holes at the marked locations. After drilling, make sure that the holes are free of any residue and/or debris.
- 4.7.2.3. Re-attach the Ramp Upper Transition and align over the drilled holes.
- 4.7.2.4. Drive the 1/4" diameter mushroom head pin drive anchors into the holes in the Ramp Upper Transition with a hammer until the head is seated flush with anchor body.

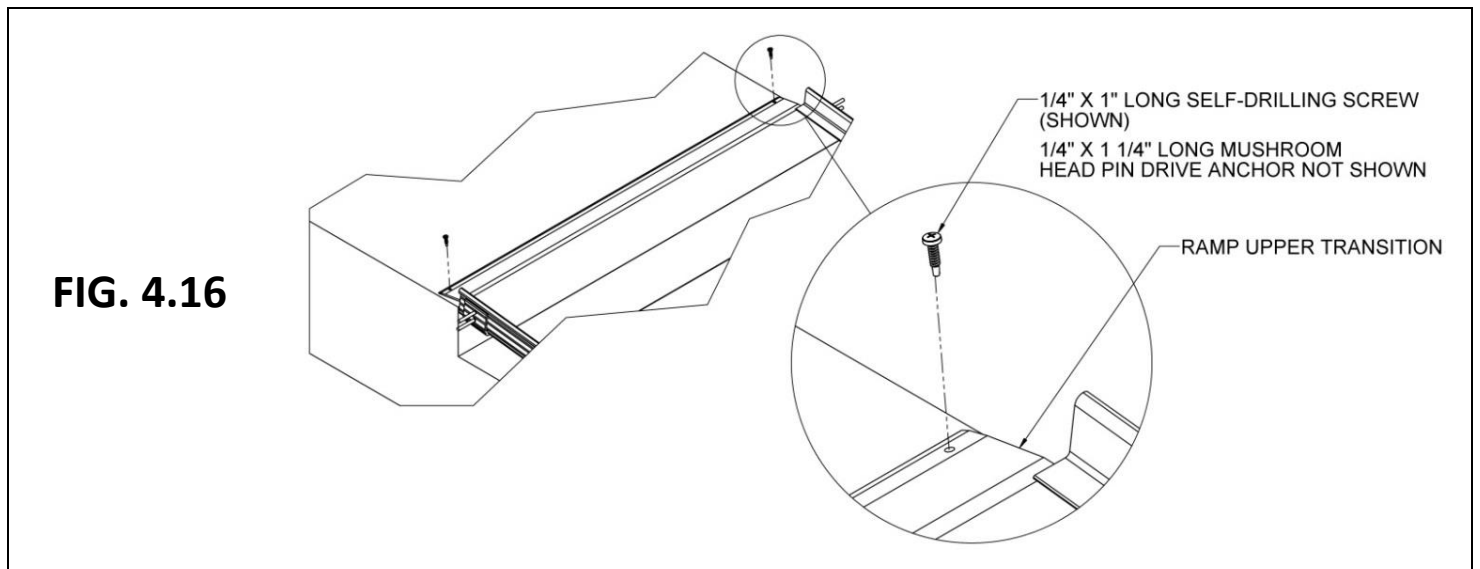

4.8. ANGLE RAMPS WITH RESPECT TO PLATFORMS, PORCHES, OR DECKS

- ✎ There are situations where it is necessary to angle ramps with respect to a platform, porch, or deck. If a ramp must be angled when attaching to a platform, a PRUT (RAMP UPPER TRANSITION), which is included in all configurations that do not have a top platform, must be used instead of a PRHP (RAMP HANGER PAIR). The same components can be used at the top and bottom of ramp or ramp run.

- 4.8.1. Angles up to approximately 3-degrees can be accommodated using the Ramp Upper Transition if it overlaps the surface of the platform, porch, or deck by at least 1" (FIG. 4.17).
- 4.8.2. The Ramp Upper Transition must be anchored to the landing. Use the provided 1/4" x 1" long self-drilling screws if anchoring to an aluminum platform.
- 4.8.3. Refer to SECTION 4.7 for anchoring to other surfaces.

- ▲ It is owner and/or installer's responsibility to use the appropriate anchor for the Ramp Upper Transition. If the Ramp Upper Transition is being attached to a surface other than an aluminum platform provided as part of the system, the appropriate anchors may need to be purchased/used.

FIG. 4.17

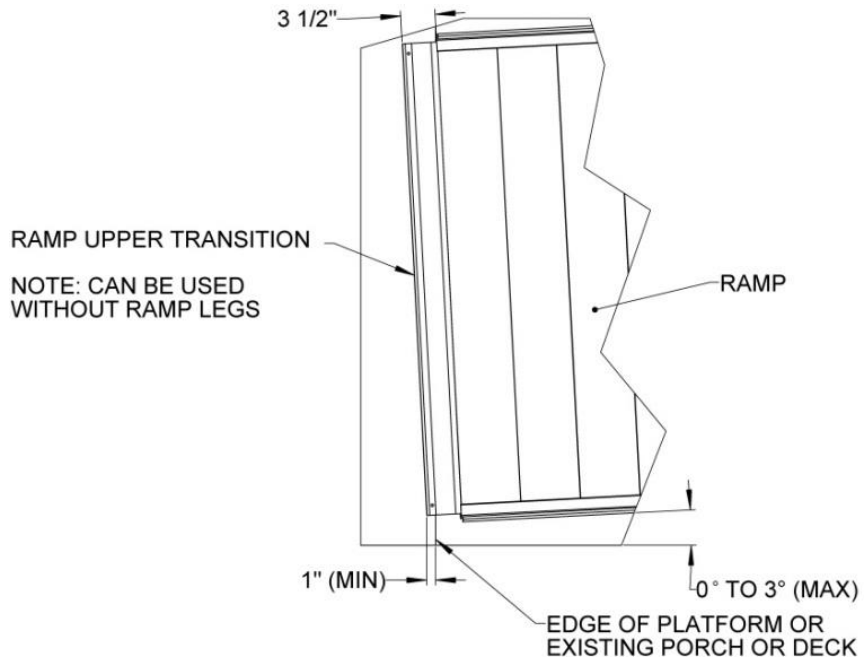

4.9. BRIDGE PLATE

✎ For configurations that include a top platform, a PBP36 (BRIDGE PLATE) is included. It is intended to be used to bridge gaps up to a maximum of 6" between a platform and a porch or deck.

4.9.1. Securing to WOOD SURFACE OR PLATFORM:

4.9.1.1. To secure to a wooden deck or platform, use the four supplied 1/4" x 1" self-drilling self-tapping screws.

4.9.2. Securing to CONCRETE:

4.9.2.1. To secure to concrete, drill a 1/4" diameter hole at least 1 1/4" deep. After drilling, ensure that the holes are free of any residue and/or debris.

4.9.2.2. Insert the four supplied pin head mushroom anchors and secure by using a hammer to drive the pin in flush with the mushroom.

- ⚠ Use the Bridge Plate in the horizontal (flat) position only.
- ⚠ It is not intended to be used as a ramp or on an incline.
- ⚠ Ensure that at least 1" on each of the supporting edges of the plate is supported on a good, sound construction surface that is free from defects (FIG. 4.18).

FIG. 4.18

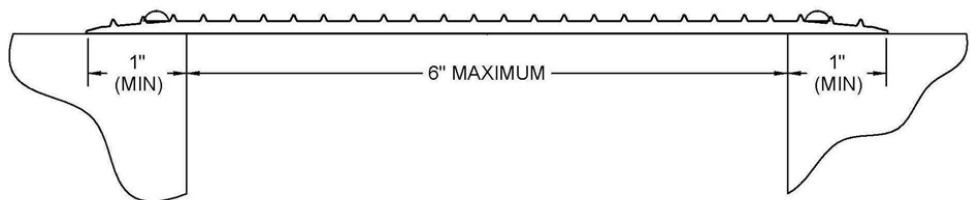

5. HANDRAILS

5.1. RAMP HANDRAILS

- 5.1.1. Two-line handrails are provided in pairs. One handrail is required on each side of the ramp, but handrails are interchangeable side to side.
- 5.1.2. In configurations with more than one ramp in a run, handrail connectors (PRRC – CONNECTOR RAMP TO RAMP) are used to join handrails together. Refer to FIGS. 5.1 and 5.2 for the following:
 - 5.1.2.1. The vertical posts of the handrails each have two holes which correspond with the studs on the end or center saddle brackets (installed in steps).
 - 5.1.2.2. Attach handrails to the studs using two each 5/16" flat washers and two each 5/16" nuts per post. Tighten 5/16" nuts just enough to hold handrail in place.
 - 5.1.2.3. If the studs do not align with the posts in the handrail, the handrail end bracket is most likely installed into the wrong threaded insert in the ramp side rail (see FIG. 4.2 for proper installation location). Slide the ramp handrail connector into one end of the upper handrail tube.
 - ✎ If connector does not fit in the tube, use pliers to lightly compress the connector while sliding into handrail tube.
 - 5.1.2.4. Slide the next handrail section over the connector, ensuring the upper handrail tubes are pushed firmly towards each other. Compress the connector. Use a rubber mallet or similar tool to fully seat as needed.
 - 5.1.2.5. Rotate the handrail until the holes in the handrail post align with the studs in the saddle brackets that are connected to the ramp. Attach with 5/16" flat washers and 5/16" nuts but tighten only enough to hold the handrail in place.
 - 5.1.2.6. Repeat for the remaining handrails in the run, then tighten all fasteners securely.

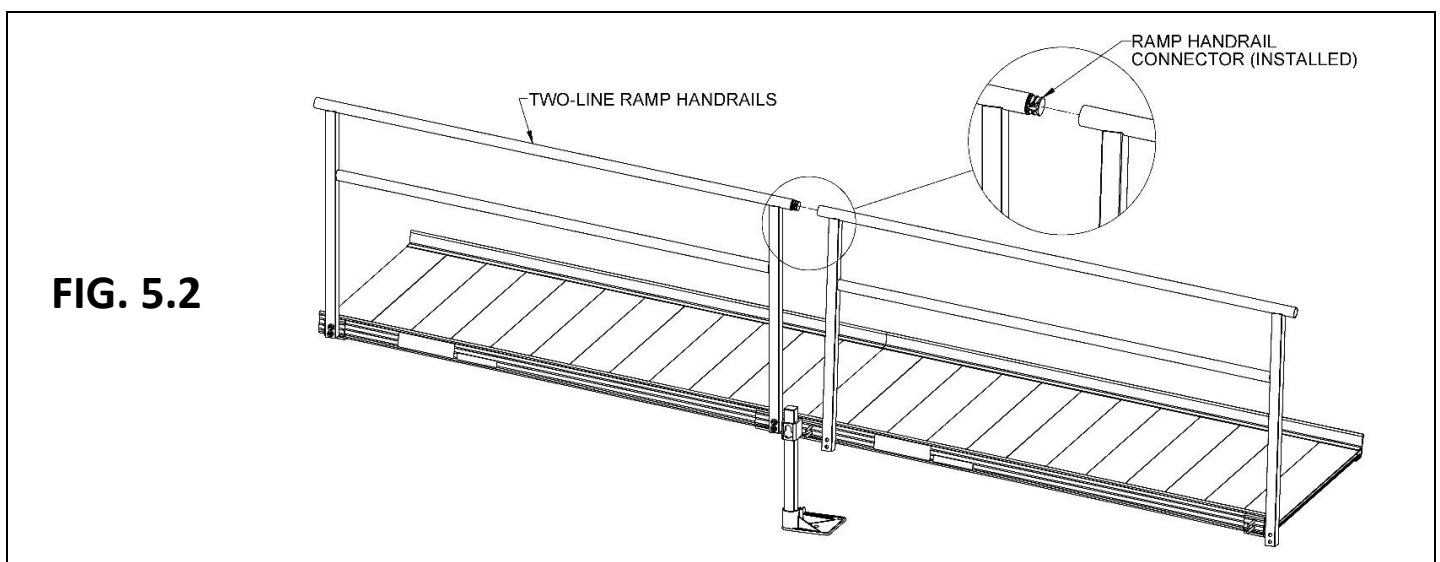
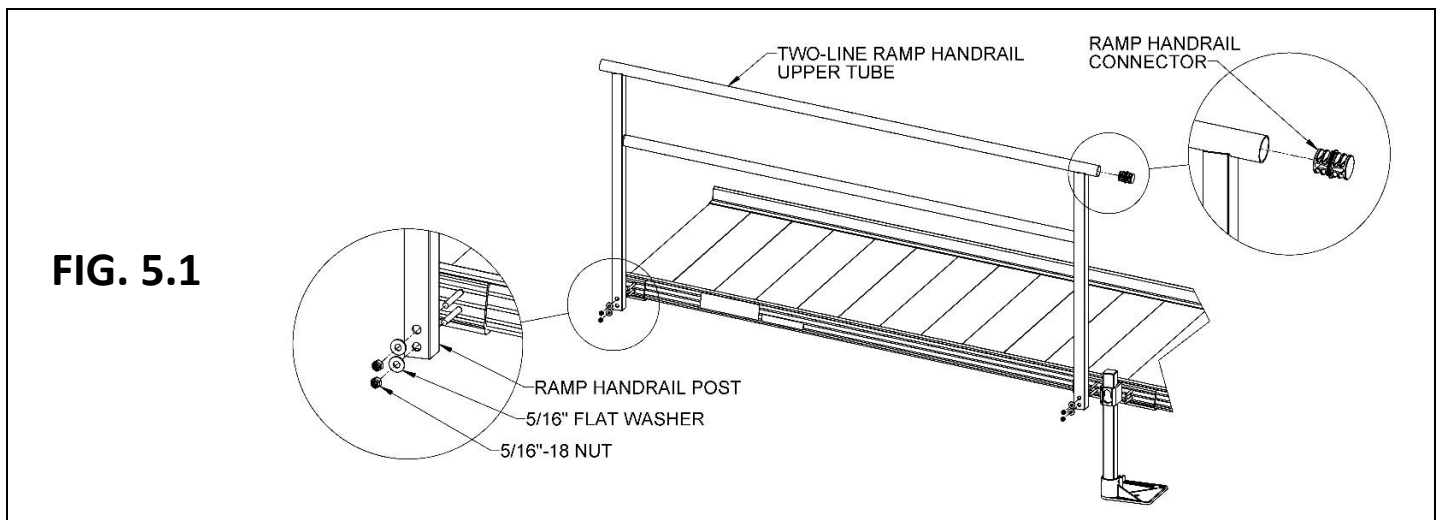

5.2. ASSEMBLE PLATFORM HANDRAILS

👉 If your configuration does not include a platform, skip to 'INSTALL RAMP HANDRAIL END LOOPS'.

5.2.1. Two-line handrails are provided in pairs when ordered with the platform. It is strongly recommended the bolts be assembled loosely and not fully tightened until all have been installed and the handrail has been installed in the platform.

5.2.2. Using holes shown (FIG. 5.3) for platform handrails, pre-assemble handrails by inserting a 5/16"-18 x 1" hex bolt through a 5/16" flat washer, the angle post, and into a 5/16"-18 round threaded insert in the handrails and curb.

FIG. 5.3

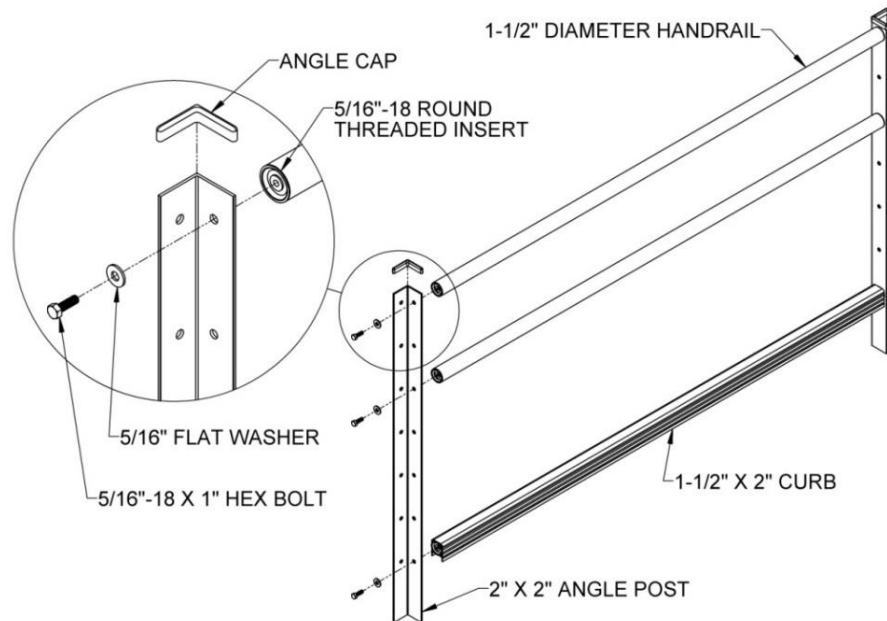

5.3. INSTALL PLATFORM HANDRAILS

- 5.3.1. Depending on the configuration, refer to FIGS. 5.4 and FIG. 5.5 as needed.
 - ✎ For U-shaped configurations, assemble handrails on both platforms as shown in FIG. 5.5.
- 5.3.2. Pre-assemble the platform handrail for both sides of a straight configuration and the “first” handrail of a turn configuration. Make sure the unattached legs of the angle posts are on the same side with respect to handrail tubes and curb and pointing outward (FIG. 5.4).
- 5.3.3. For the “second” handrail in a turn configuration, only assemble one angle post as described above, paying attention to how it will connect to the “first” handrail so the angle post will be oriented correctly.
- 5.3.4. For straight platform configurations and the “first” handrail on a turn platform, drop platform handrails into the corner pockets (FIG. 5.5). The curb should rest on top of the corner pocket.
- 5.3.5. For the “second” handrail on a turn platform, insert the angle post into a corner pocket at 90-degrees from the “first” handrail, then install 5/16”-18 x 1” long hex bolt through a 5/16” flat washer, the angle post in the “first” handrail, and into a 5/16”-18 threaded inserts in the “second” handrail and curb (FIG. 5.5). Tighten all fasteners securely.
- 5.3.6. Tighten two each set screws on the inside of the platform corner pocket. One set screw is located above the platform deck and the other is underneath (FIG. 5.4).
- 5.3.7. Install an angle cap on top of each handrail post. Use construction adhesive to bond the cap in place (FIG. 5.3).
- 5.3.8. Ensure all fasteners are tightened securely.

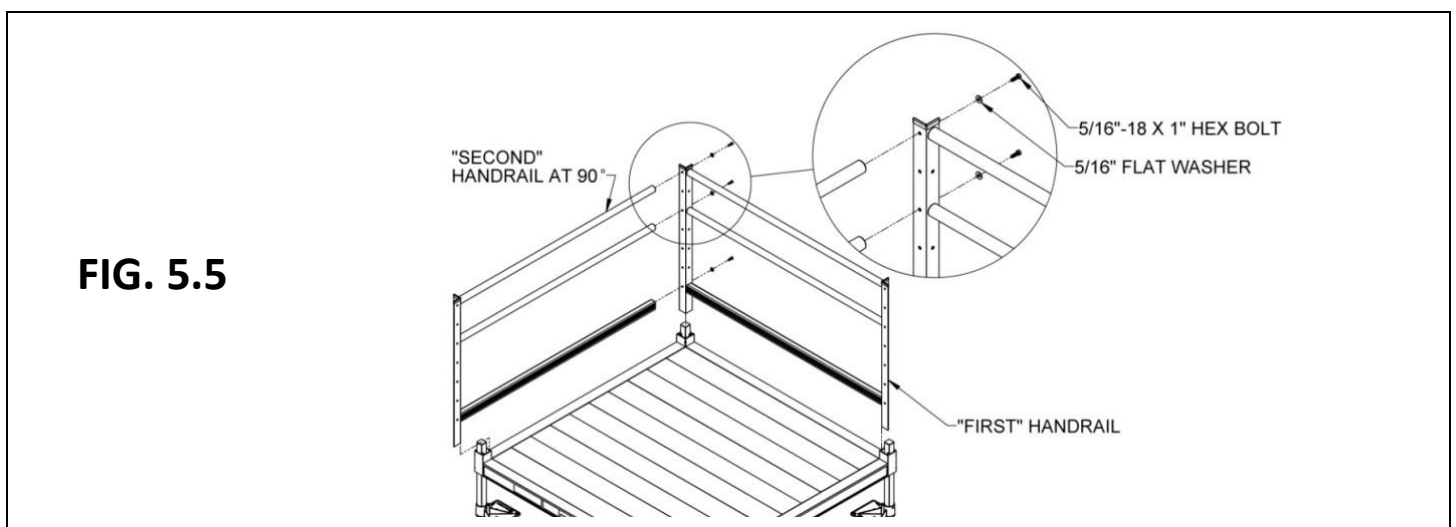
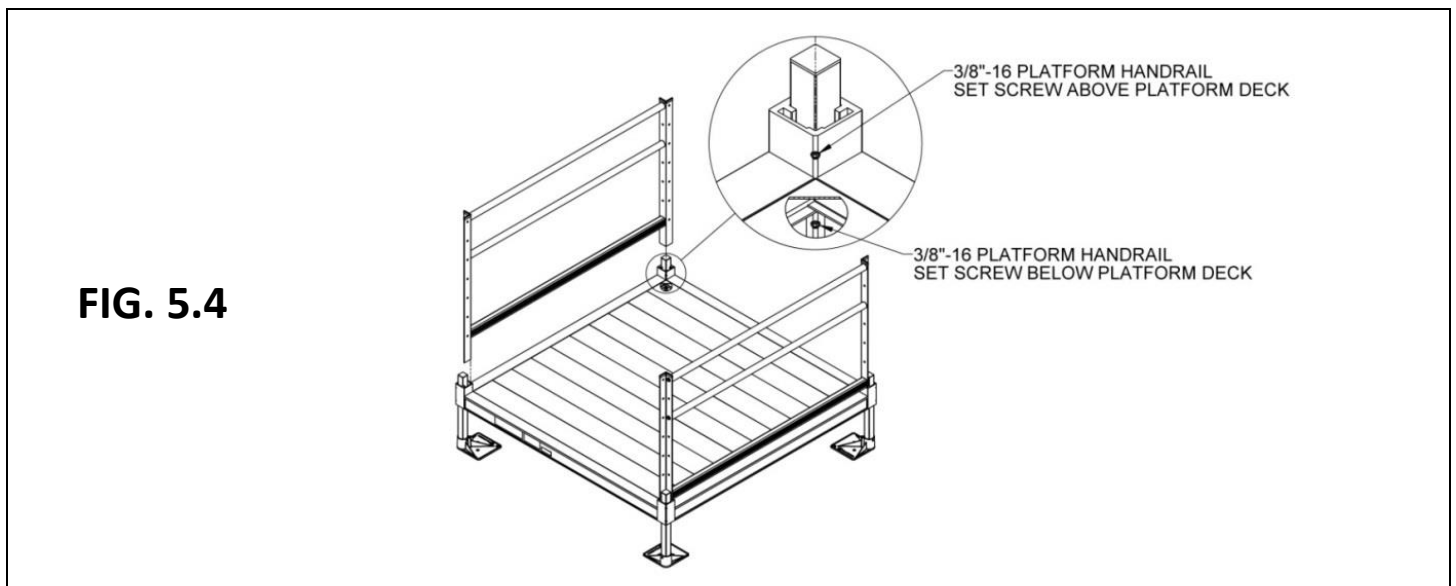

6. CLOSURES

6.1. CLOSURE UPPER RAIL AND CURB

- 6.1.1. Closures fill the space between ramp handrails and platform posts. As a standard, the closure comes with components which require the ramp to be mounted to one side or the other of a platform. When mounting to the side, the ramp handrail post should be positioned 1-1/2" (minimum) to 2" from the inside of the platform post. The installation of the upper rail is the same regardless of the closure's position.
- 6.1.2. If installing a closure on a platform in the "straight" configuration, the 2" x 2" angle post will already be in place; skip to step 6.4.
- 6.1.3. If installing on a platform in the "L-shaped" configuration, install the 2" x 2" angle post not attached to a platform handrail in the open platform corner pocket. Align the bottom of the post with the bottom of the corner pocket and tighten the set screws securely (FIG. 6.1).
- 6.1.4. Install an angle cap on top of the handrail post (FIG. 6.1). Use construction adhesive to bond the cap in place.
- 6.1.5. First install the upper rail, the rail connecting the ramp handrail to the platform post.
 - 6.1.5.1. Insert an adjustable elbow in the ramp handrail. Loosen the elbow assembly screws and position the round portion of the adjustable elbow so it is aligned with the upper hole in the angle post and the face is parallel to the post.
 - 6.1.5.2. Measure the gap between the face and the post (FIG. 6.2).

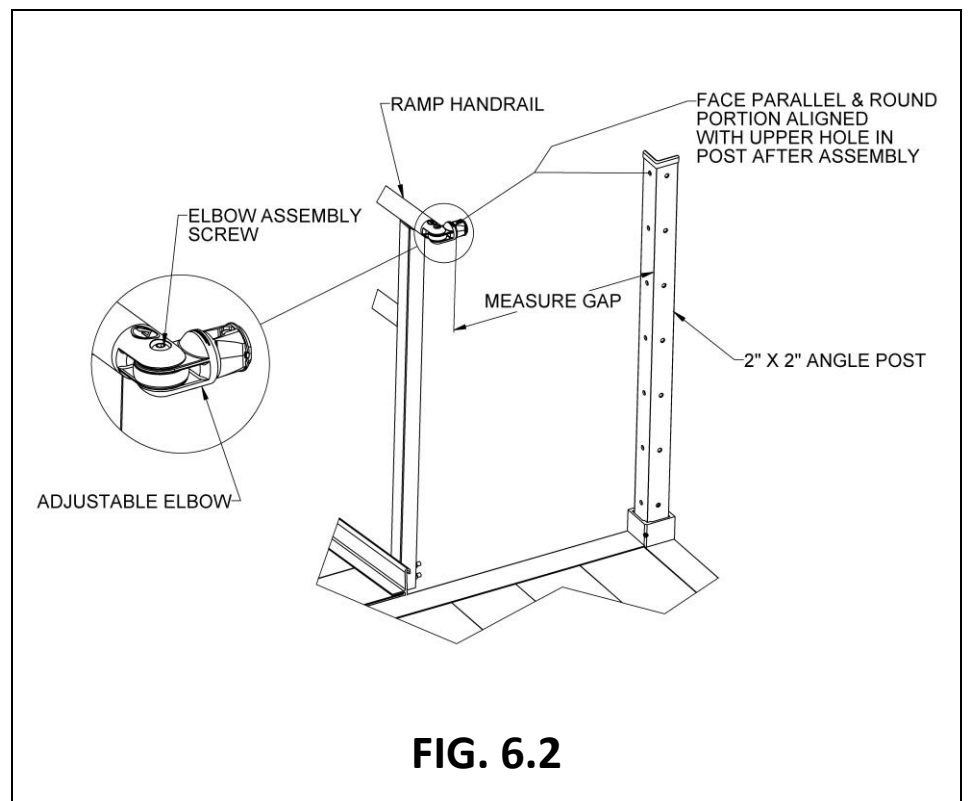
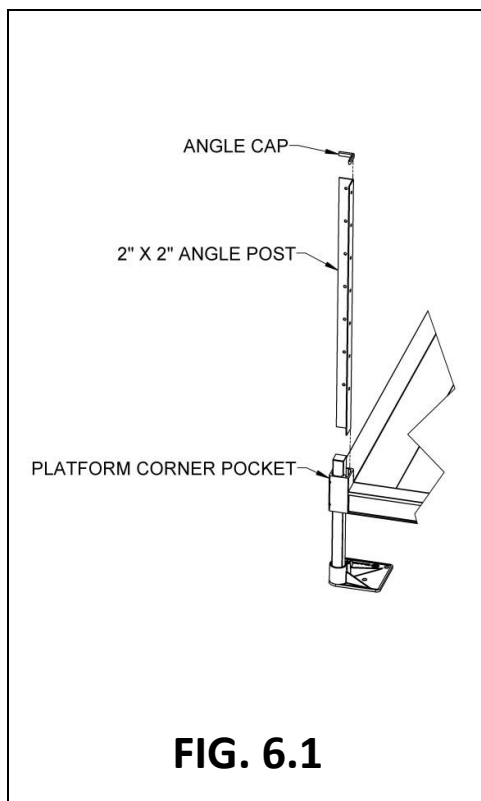

- 6.1.6. Cut the 1-1/2" diameter round tube to the length measured less 1/16" (FIG. 6.3).
- 6.1.7. Using a metal file, smooth any sharp edges from the cutting.
- 6.1.8. Disassemble the adjustable elbow by removing the screw, nut, and center insert (FIG. 6.4).
- 6.1.9. Install an elbow half into the end of the cut tube which will attach to the ramp handrail and a 5/16"-18 round threaded insert into the end which will attach to the post (FIG. 6.3).
- 6.1.10. Tighten internal set screws of the adjustable elbow (FIG. 6.4).

FIG. 6.3

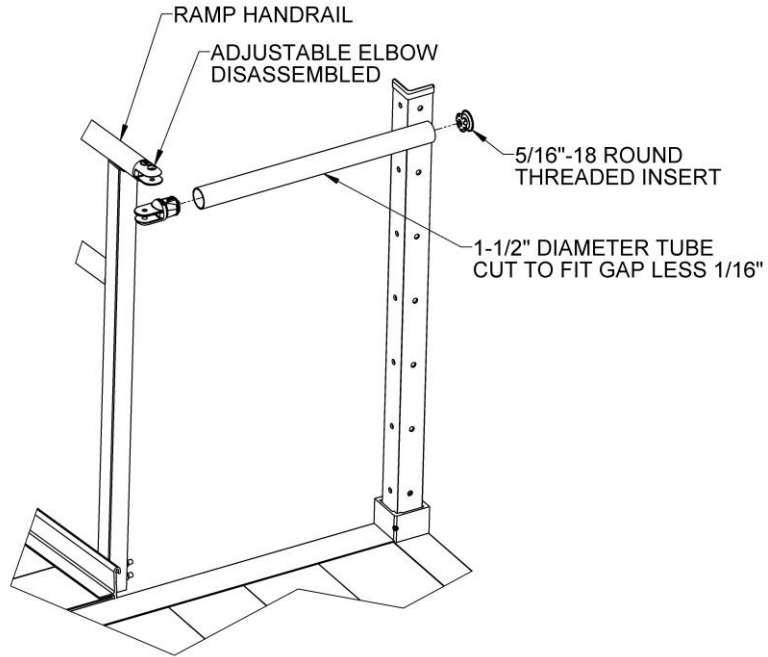
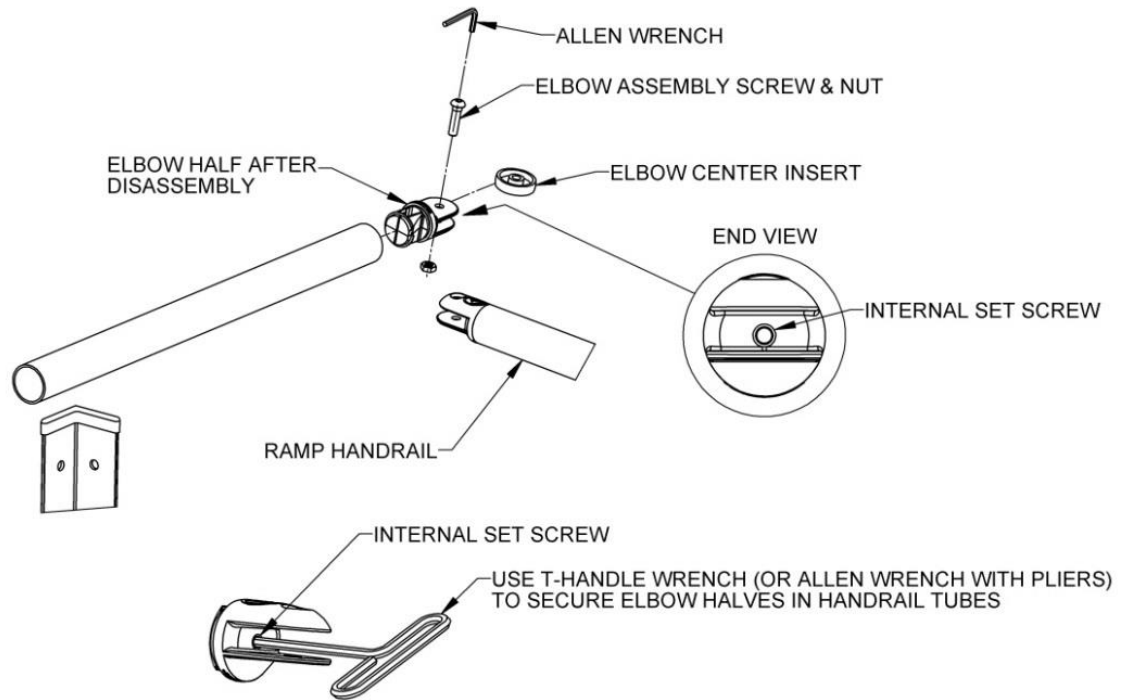
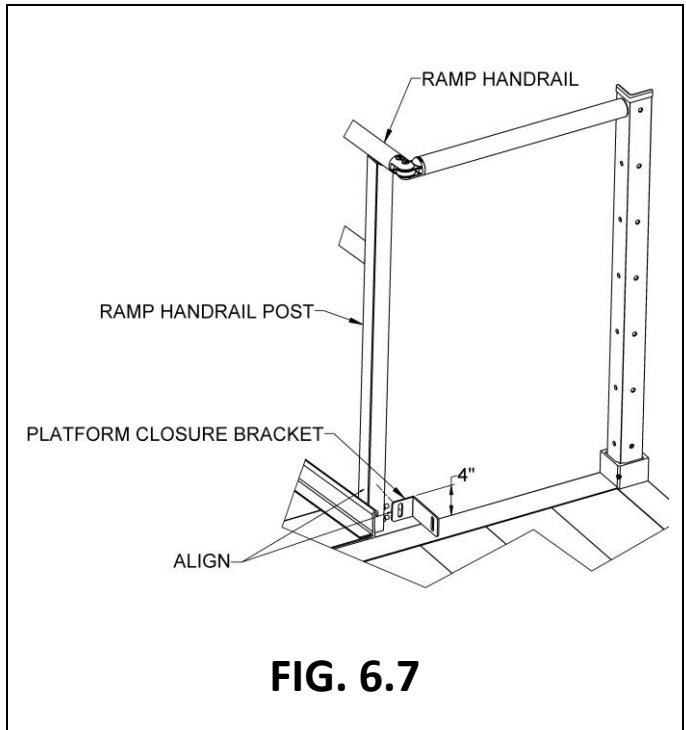
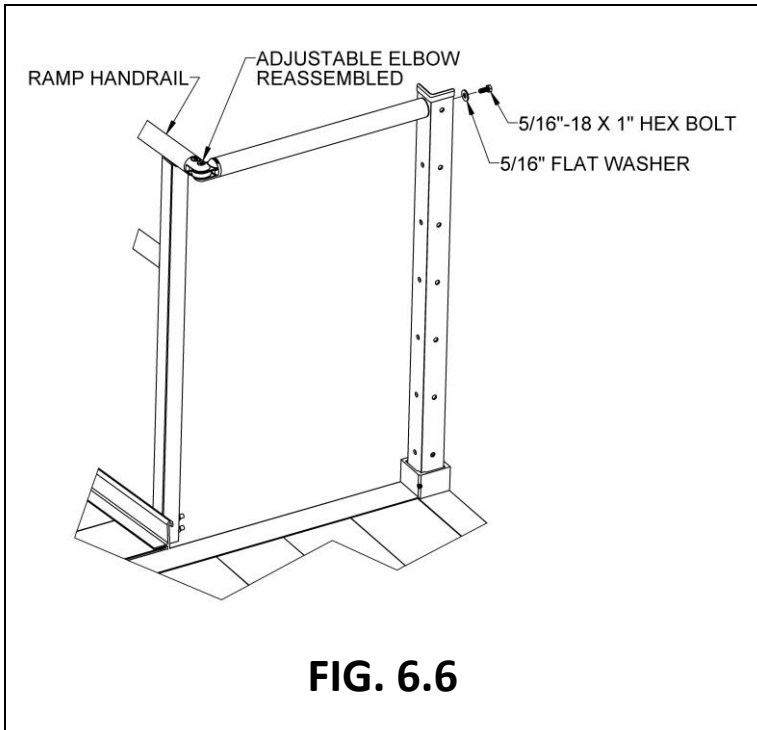
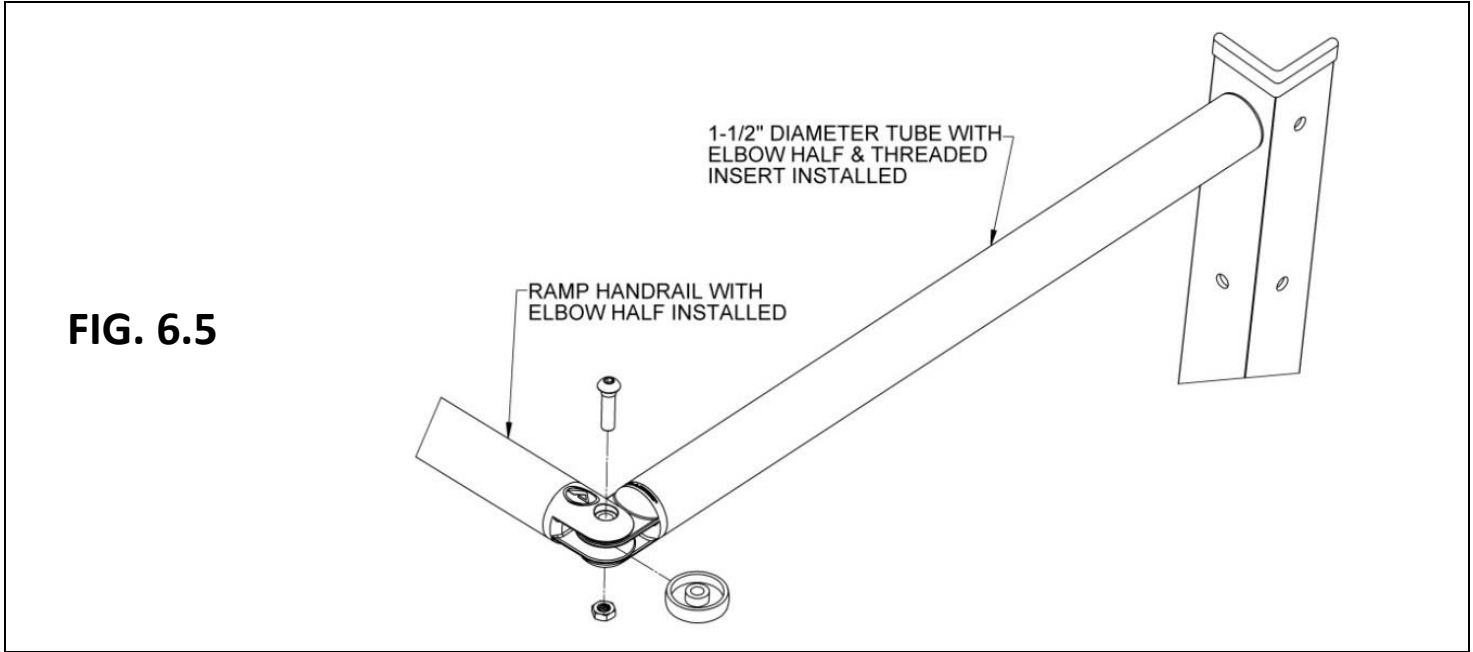

FIG. 6.4



- 6.1.11. Reassemble elbow by replacing center insert and securing with screw and nut (FIG. 6.5).
- 6.1.12. Install a 5/16"-18 x 1" hex bolt through a 5/16" flat washer and the upper hole in the angle post into the 5/16"-18 round threaded insert (FIG. 6.6), then tighten all fasteners securely.
- 6.1.13. Test to ensure elbow is properly secured and attached. If needed, tighten internal set screws to secure more rigidly.
- 6.1.14. Once the upper rail is in place, install the 1-1/2" x 2" curb.
- 6.1.15. Locate a platform closure bracket and clamp the short leg of the bracket to the ramp handrail post 4" above the platform deck with the short leg aligned with the post. Orient the bracket so that the long leg is on the same side as and parallel to the platform post (FIG. 6.7).



- 6.1.16. Measure the gap between the long leg of the bracket and the post then cut the 1-1/2" x 2" curb to the measured length, less 1/8" to account for the threaded inserts which will be installed after cutting (FIG. 6.8).
- 6.1.17. Insert 5/16"-18 square threaded inserts into both ends of the curb. Use a rubber mallet or similar tool to fully seat the threaded inserts as needed (FIG. 6.8).
- 6.1.18. Install 5/16"-18 x 1" hex bolts through a 5/16" flat washers, the long leg of the closure bracket, and the platform post into the 5/16"-18 round threaded inserts installed in the curb. Use the hole which is 1/2" above the lowermost hole in the platform post to align the curb correctly (FIG. 6.9).
- 6.1.19. Unclamp the closure bracket and drive a 5/16"-18 x 1-1/4" self-drilling, self-tapping hex washer head screw, centered in the slot, through the platform closure bracket and into the ramp handrail post (FIG. 6.9). Tighten securely but use caution not to overtighten and strip the threads.
- 6.1.20. Ensure all fasteners are tightened securely.

FIG. 6.8

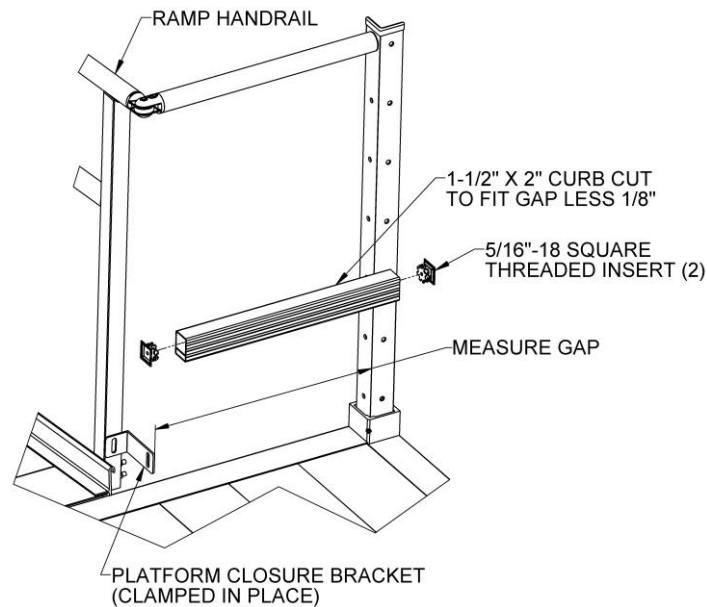
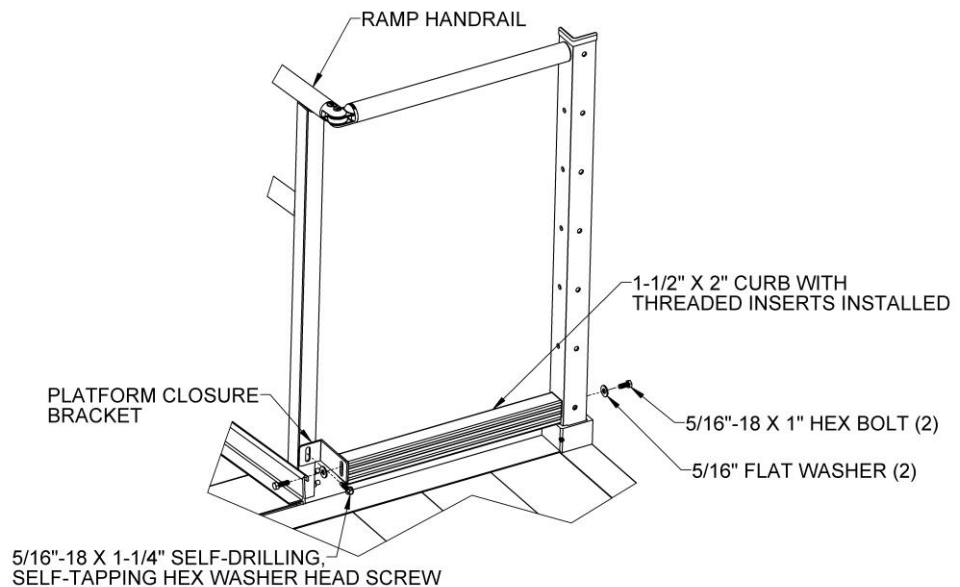
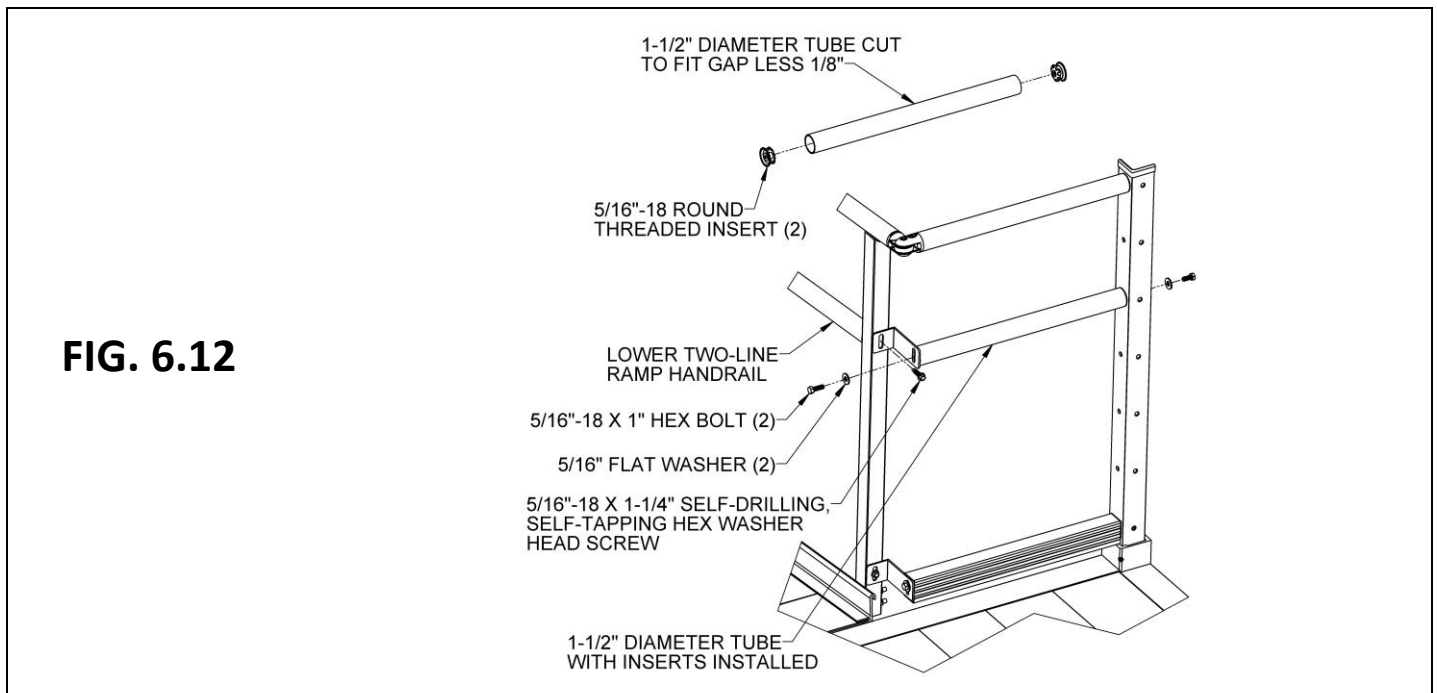
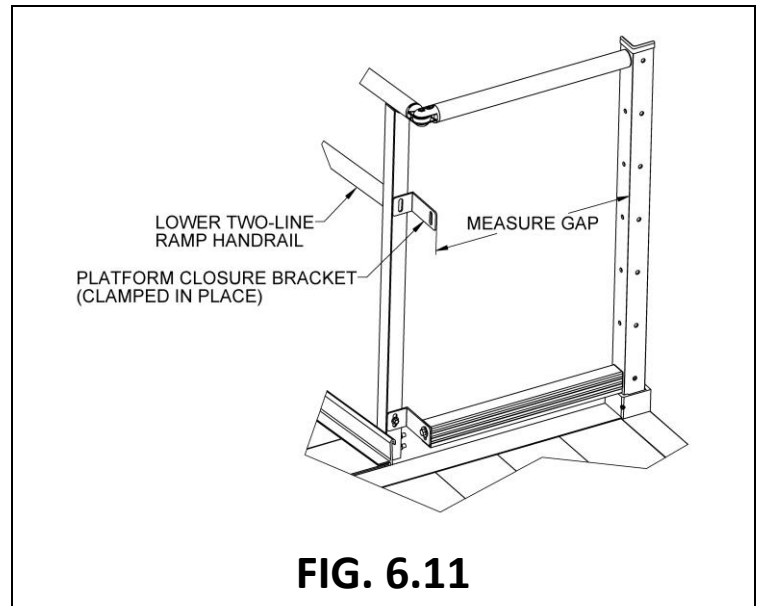
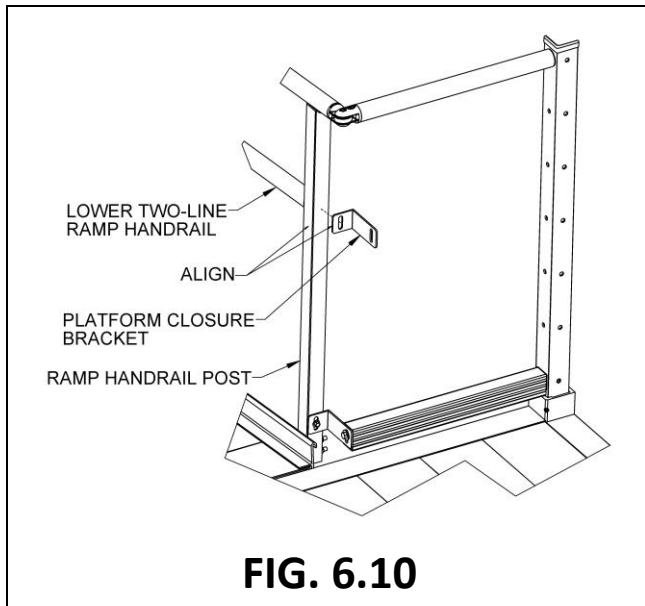

FIG. 6.9



6.2. CLOSURE LOWER RAIL

- 6.2.1. Clamp the platform closure bracket (bracket) to the ramp handrail post such that short leg is centered on the lower two-line ramp handrail and aligned with the post. Orient the bracket so the long leg is on the same side as and parallel to the platform post (FIG. 6.10).
- 6.2.2. Measure the gap between the long leg of the bracket and platform post (FIG. 6.11).
- 6.2.3. Cut the 1 1/2" diameter round tube to the measured gap length less 1/8" to account for the threaded inserts which will be installed after cutting (FIG. 6.12).
- 6.2.4. Using a metal file, smooth all sharp edges from cutting the round tube.
- 6.2.5. Install 5/16"-18 round threaded inserts into both ends of the cut tube. Use a rubber mallet or similar tool to fully seat the threaded inserts (FIG. 6.12).
- 6.2.6. Install 5/16"-18 x 1" hex bolts through a 5/16" flat washers and the slot in the long leg of the bracket and the third hole from the top of the platform post into the threaded inserts installed in the previous step, then tighten all fasteners securely (FIG. 6.12).
- 6.2.7. Unclamp the bracket and drive a 5/16"-18 x 1-1/4" self-drilling, self-tapping hex washer head screw, centered in the slot, through the bracket and into the ramp handrail post (FIG. 6.12). Tighten securely but use caution not to overtighten and strip the threads.



6.3. U-SHAPED CLOSURE

- 6.3.1. Closures for a U-shaped configuration are created using the same method described in the preceding section.
- 6.3.2. Install the upper rail, curb, and lower rail as described in 'HANDRAILS'.
- 6.3.3. FIG. 6.13 shows the completed assembly.

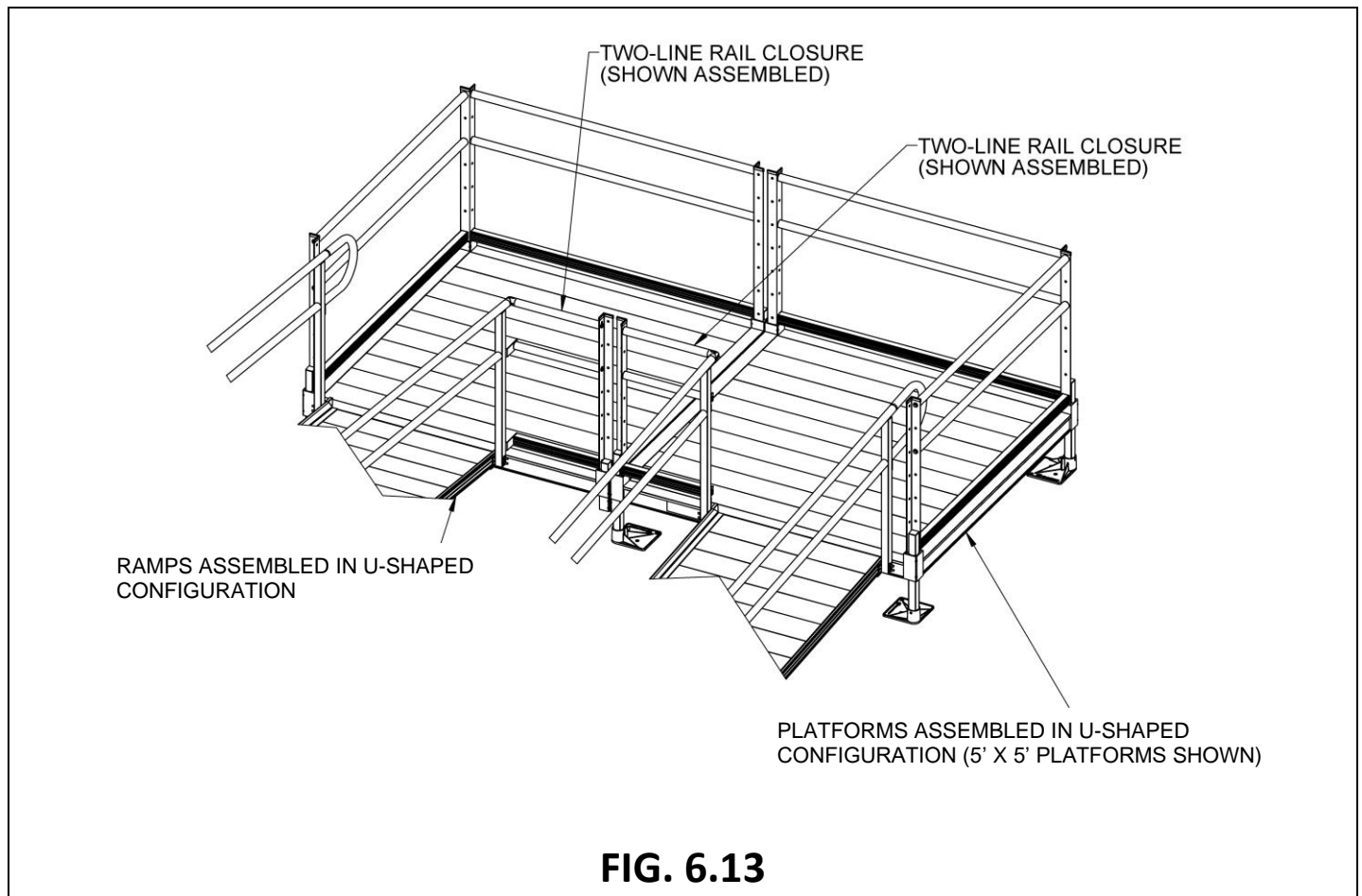

7. FINAL PLATFORM/RAMP STEPS AND CHECKS

7.1. SECURE RAMP TO PLATFORM

- 7.1.1. Once the positioning of all ramps and platforms, and installation of all handrails, connectors, and end loops are complete, you will need to secure ramps to platforms with Ramp End Clips (clips), included in PRHP - RAMP HANGER PAIR.
 - ▲ Use two clips at all locations where ramps meet platforms.
- 7.1.2. Position each clip with the hole pointing up and oriented as shown (FIG. 7.1), then insert the short end of the clip into small gap between the ramp and the platform in the area where the ramp side rail overlaps the ramp end tread (FIG. 7.1).
- 7.1.3. Before the clip contacts the ramp side rail, rotate the clip so the short end extends into the recess under the ramp end tread (FIG. 7.1).
- 7.1.4. Use the hole in the clip as a template to drill 1/8" pilot hole in the platform side rail, then use the 1/4" x 1" long self-drilling screws to secure the clip to the platform side rail (FIG. 7.2).
- 7.1.5. Top view of the completed process (FIG. 7.3).

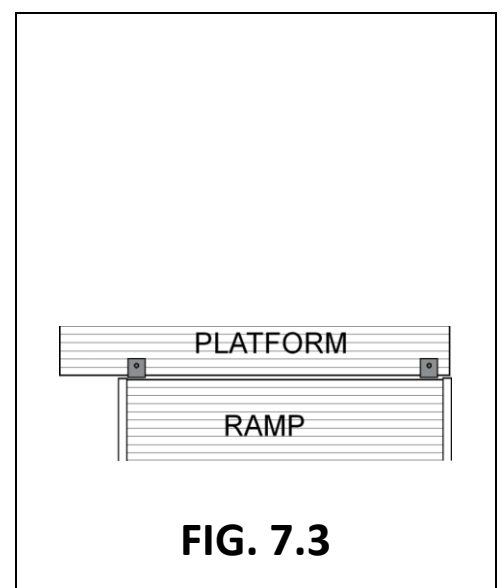
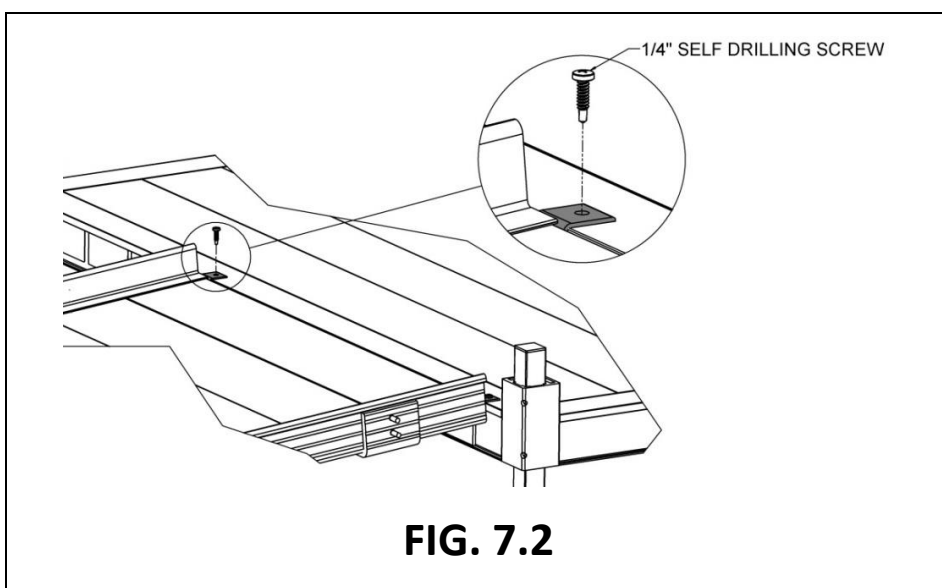
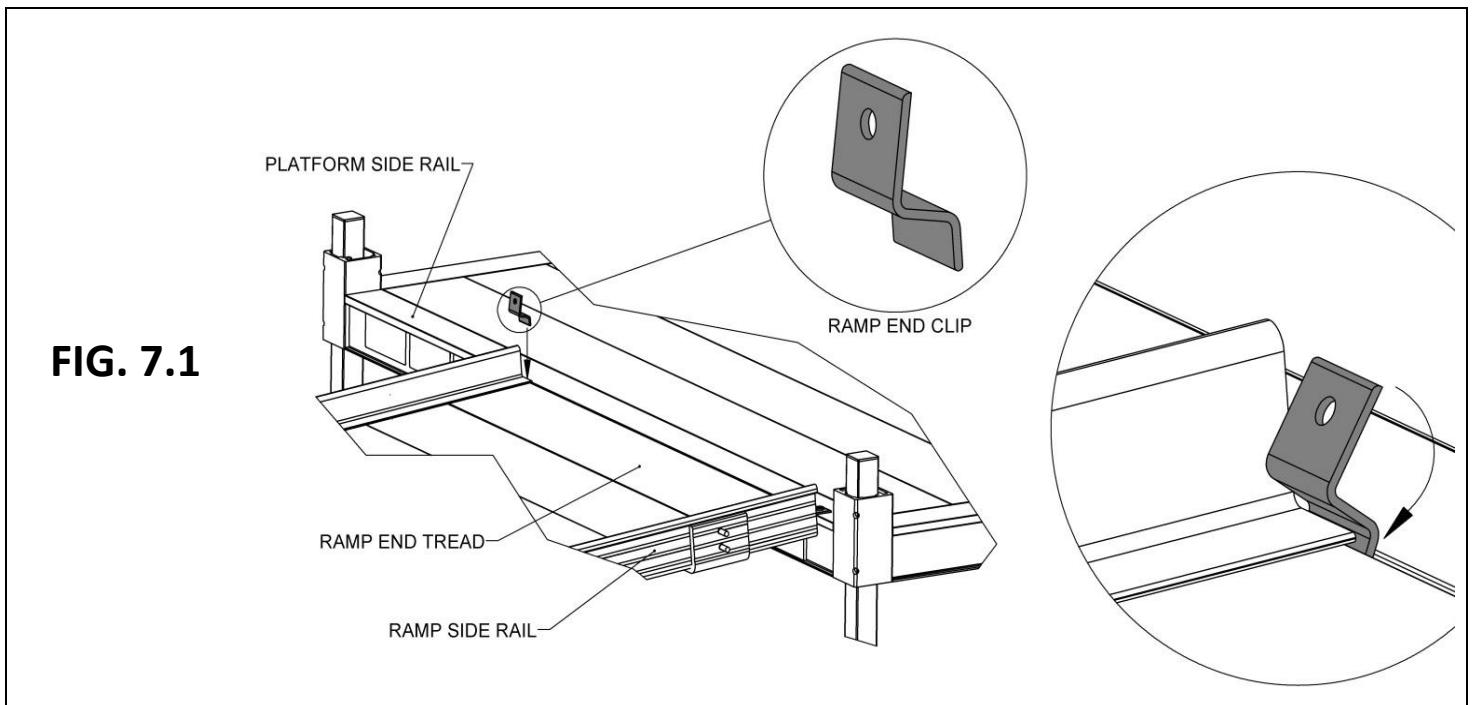

7.2. INSTALL RAMP HANDRAIL END LOOPS

7.2.1. Upper and lower end loops (FIG. 7.4) are installed in the same manner. If the end loop being installed doesn't fit correctly (i.e., the attachment plate is angled the wrong direction, the lower leg seems too long or short, etc.), it is most likely being installed on the wrong end of the ramp or ramp run.

7.2.1.1. Install the O-ring over the swaged portion of the end loop until it rests against the loop shoulder (FIG. 7.5).

7.2.1.2. Install one 1/4" x 1" long hex washer head self-drilling screw through the hole in the end loop attachment plate into the ramp handrail post.

7.2.1.3. Tighten securely (FIG. 7.6).

FIG. 7.4

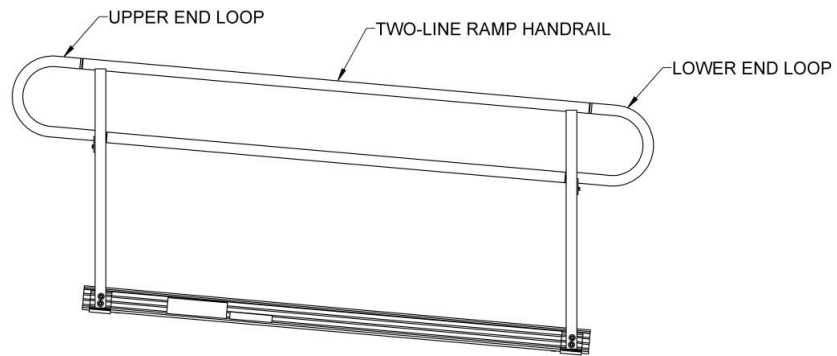

FIG. 7.5

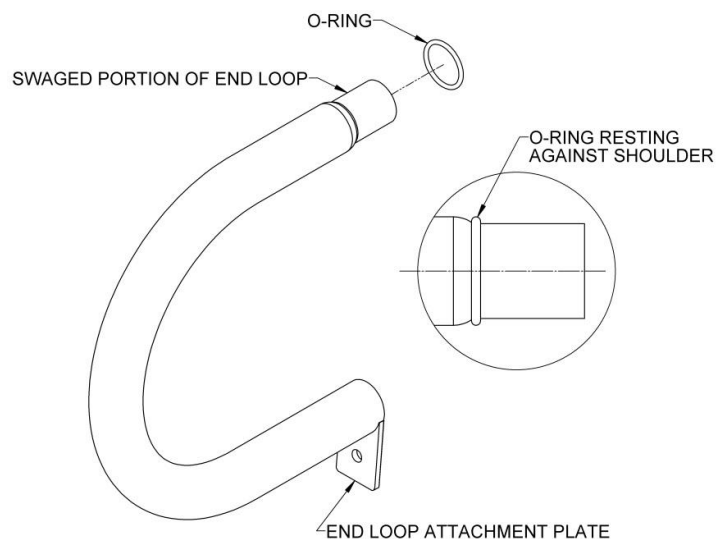
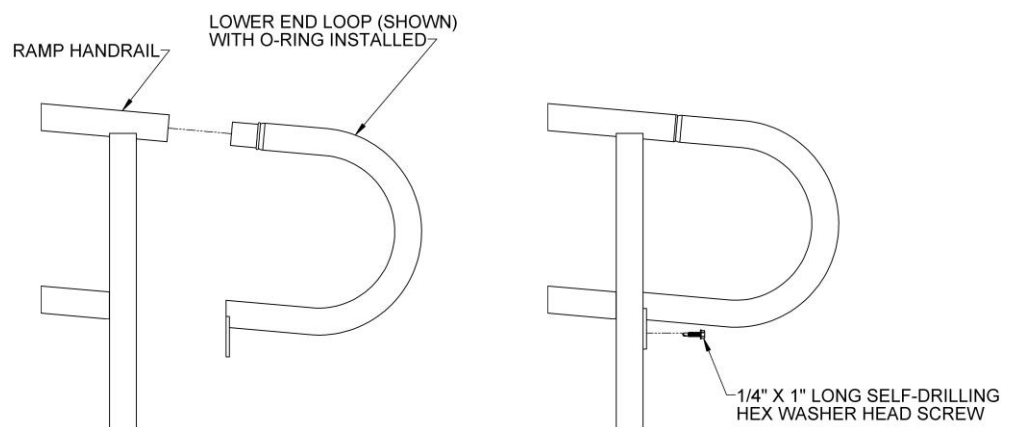

FIG. 7.6



7.3. INSTALL RAMP CORNER PROTECTORS

- 7.3.1. Install protective caps over side rail corners by placing one cap on each side at both the top and bottom of the ramp or ramp run (FIG. 7.7). If necessary, use construction adhesive to bond the cap to the ramp.

7.4. TOUCH-UP ARCHITECTURALLY FINISHED HANDRAILS

- 7.4.1. As needed, use sandpaper (180 grit or equivalent) for blending scratches on architecturally finished handrails. Sand in direction of the grain as shown (FIG. 7.8).

7.5. FINAL CHECKS

- 7.5.1. Ensure that all fasteners are in place and fastened securely.
- 7.5.2. Walk on the assembled system, checking for any undue movement.
 - ▲ Use the assembled system only after system stability has been confirmed.
- 7.5.3. Remove any metal chips and other assembly debris.
- 7.5.4. Ensure that system level and slope has not shifted during installation.
- 7.5.5. Ensure that all handrail ends are covered with loops.

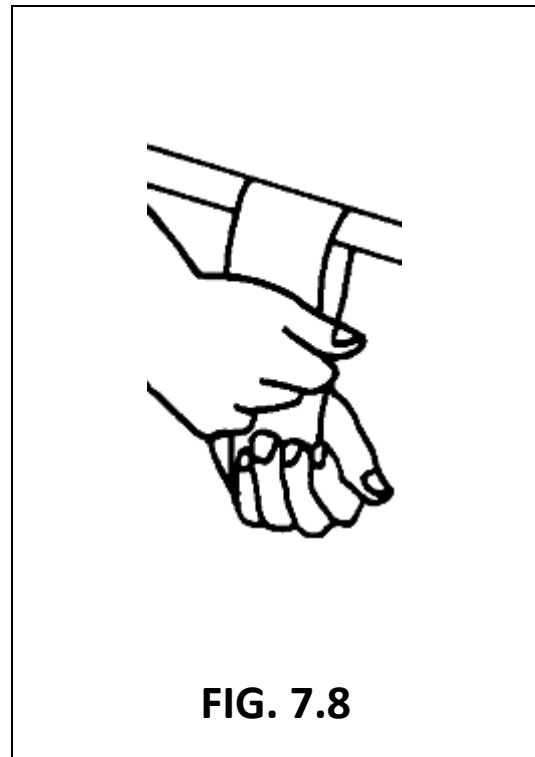
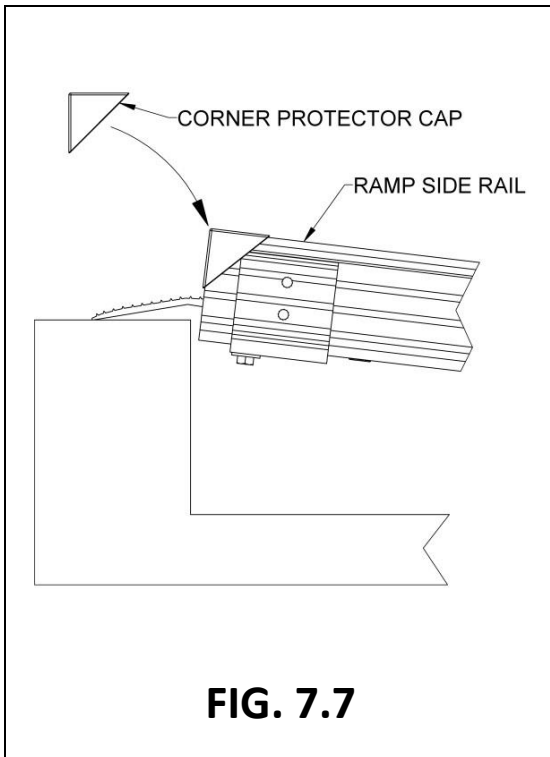

8. **OPTIONAL EQUIPMENT**

8.1. LANDING PAD

- ✎ The PLP (LANDING PAD) is used at the bottom of a ramp or ramp run to assist mobility on soft ground. This is purchased separately and not included in any of the configurations.
- 8.1.1. Contour the ground where the landing pad will be positioned to remove any high or low areas which would prevent portions of the landing from contacting the ground.
 - ⚠ The underside of the landing pad must be fully supported by the ground. It should never be used in an elevated position like a ramp or a platform.
- 8.1.2. Slide the bottom plate into one of the three available slots (FIG. 8.1).
 - ⚠ The ramp must be installed on the side marked for ramp attachment.
- 8.1.3. After installing the bottom plate, install #8-32 hex washer head thread cutting screws into the screw slots on both sides (FIG. 8.2).

FIG. 8.1

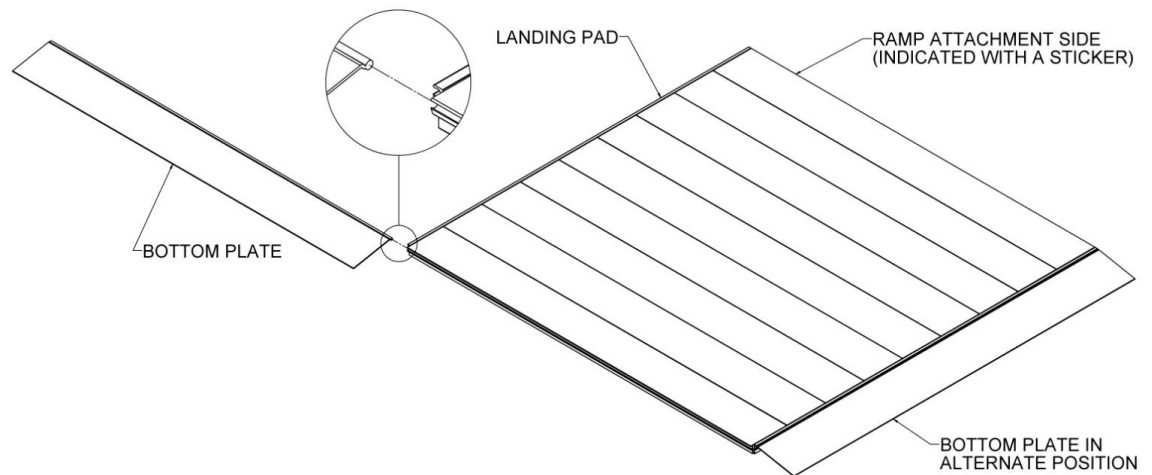
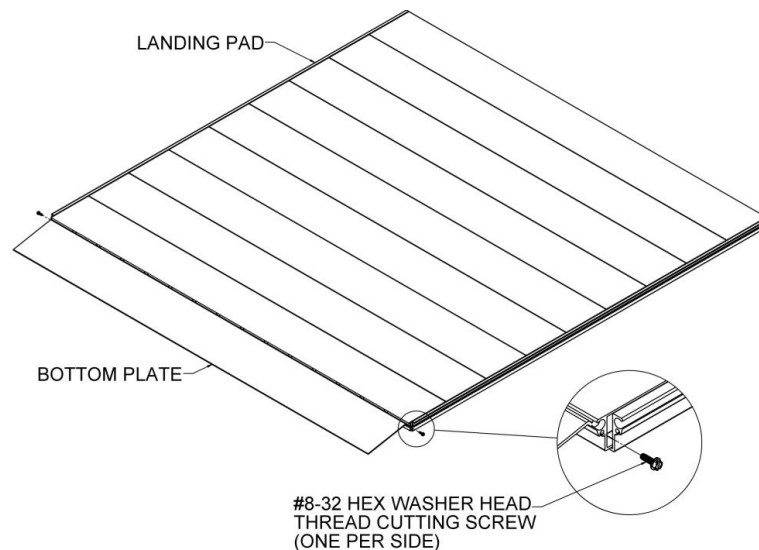

FIG. 8.2



8.2. RAMP LOWER TRANSITION

✎ When using the landing pad, the ramp lower transition replaces the ramp ground transition at the end of the ramp system.

- 8.2.1. Lift the end of the ramp and install the lower transition as shown (FIG. 8.3).
- 8.2.2. Slide the landing pad underneath the lower transition and end of the ramp. Make sure the landing pad is oriented so that the side marked for ramp attachment is at the end of the ramp.
- 8.2.3. Ensure that the lower transition extends fully onto the pad.
- 8.2.4. Attach ramp's lower transition to the landing pad using two provided 1/4" self-drilling screws (FIG. 8.4).

FIG. 8.3

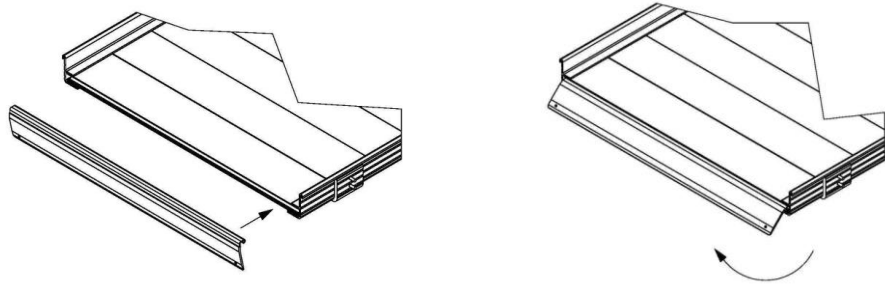
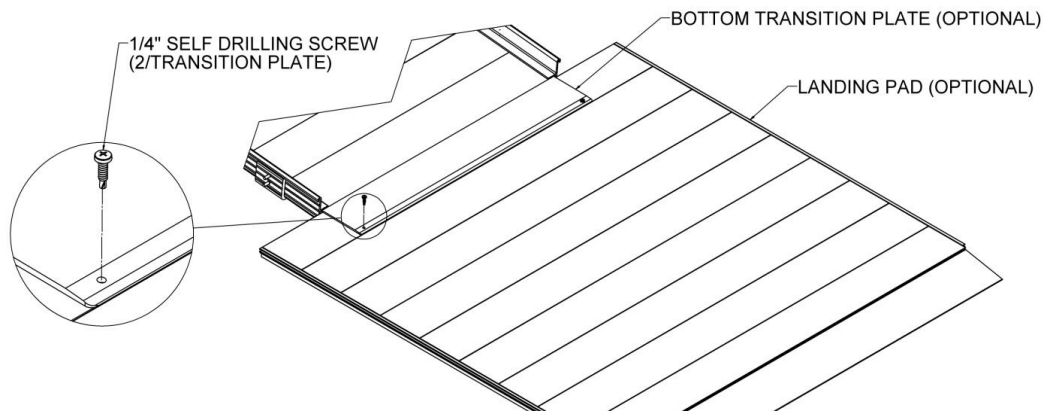

FIG. 8.4



9. MAINTENANCE & SAFETY

9.1. PERIODIC MAINTENANCE AND SAFETY

- 9.1.1. Caution should be always used. Proper maintenance and upkeep to the ramp surface is vital.
- 9.1.2. Only use the system with a qualified helper.
- 9.1.3. Always use a lap belt if using the system with mobility equipment.
- 9.1.4. Before use with mobility equipment, refer to your mobility equipment's owner guide for acceptable ramp usage, including proper slope/incline, chair direction, etc.; never exceed its recommendations.
- 9.1.5. Before each use, check the system for worn, loose, or damaged parts. If you find any of these conditions, do not use the system and contact your dealer for service or repairs; failure to do so may result in serious injury.
- 9.1.6. At all times, keep the system clear of dirt, leaves, and other debris that may accumulate on the surface. Simply sweeping the ramp or using a garden hose will usually suffice, but, if needed, a damp cloth or soft brush with soap and water can be used (avoid use of alkaline detergents).
- 9.1.7. If tread surface is covered with ice and/or snow, remove ice and/or snow before use. Snow accumulation must be shoveled, and the tread surface swept clean. Magnesium Chloride may be used to melt snow or ice accumulation on the ramp; however, after the snow and/or ice threat has cleared, be sure to clean the tread surface with soap and water (avoiding alkaloid detergents) to remove Magnesium Chloride residue. See DEICING below for additional information.
- 9.1.8. Keep the system clear of debris and clutter. Do not use if walking surface is unsafe.
- 9.1.9. Do not run, jump, or play on or around the system, including climbing on or between the handrails.
- 9.1.10. Do not use any part of the system to support planters, lights, decorations, etc.
- 9.1.11. The system may be slippery in wet conditions; use caution as traction may be reduced.

10. DEICING

- ⚠ For the safety of all users, it is important to keep your system clear of snow, ice, and other debris.
- ⚠ Always follow the deicing agent manufacturer's directions.
- ⚠ EZ-ACCESS® will not be held responsible for any injuries or damages that arise from the information provided. ALWAYS check with the deicing product's manufacturer or your local supplier to determine which method is best for your situation.
- ⚠ After the snow and/or ice threat has cleared, be sure to clean the tread surface with mild soap and water (avoid alkaline detergents) to remove deicing residue.
 - ✋ Sodium Chloride (salt) and Calcium Chloride are particularly damaging to newly poured concrete. In addition, these chemicals should not be applied to brick and stone surfaces.
 - ✋ While care has been taken to ensure that the table below is accurate, the information shown is not all-inclusive. Manufacturers of deicing products may make changes to their products as well as recommended functions and usage requirements. The deicing method you choose should be researched with your deicer supplier so you can determine which method is best for your situation.
 - ✋ The information below is taken from Fact Sheet 707, Cooperative Extension Service, University of Maryland at College Park, University of Maryland Eastern Shore and was up to date at the time of this manual's publication.

PRODUCT	MIN. WORKING TEMP (°F)	SPEED OF ACTION	DAMAGES CONCRETE & METAL	HARMFUL TO PLANTS
MAGNESIUM CHLORIDE	-13	VERY FAST	NO	MODERATE
CALCIUM CHLORIDE	5	FAST	YES	YES
SODIUM CHLORIDE (SALT)	18	MODERATE	YES	YES
POTASSIUM CHLORIDE	25	SLOW	OK ON OLD CONCRETE	MODERATE
CALCIUM MAGNESIUM ACETATE (CMA)	25	SLOW	NO	NO

Thank you for choosing EZ-ACCESS[®]
for your accessibility needs.

