



Phoenix, Height Adjustable Shower Chair

Hygiene Equipment
Designed for People

Phoenix, Height Adjustable

Multifunction Shower Chair, height adjustment with either electric or hydraulic option. Polyamide nylon construction with stainless steel fasteners guarantees no rust.



Registered at Medical Products Agency, Germany, as a MD Class 1 product, MDR 2017/745.

TR reserves the right to make design changes and/or improvements without notice.



Reclining and height adjustable shower chair. Soft and durable polyurethane seat, backrest and leg support allows for comfortable positioning and easy cleaning. Hygiene bucket with vacuum seal top included.



TR EQUIPMENT



Phoenix, Height Adjustable Shower Chair

Hygiene Equipment
Designed for People

Dimensions (cm)

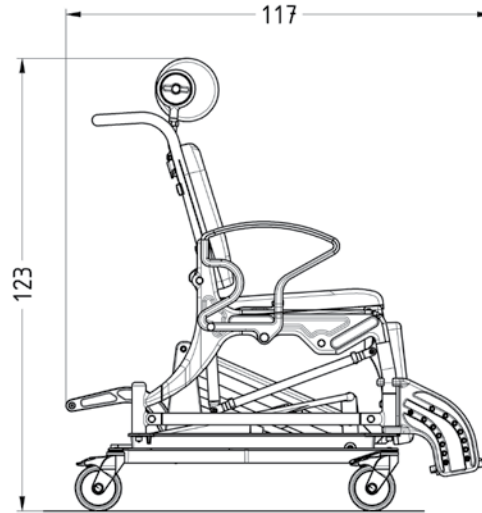
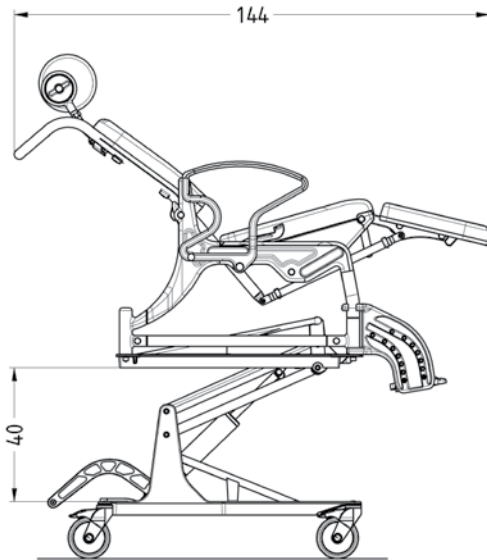

Technical specifications

| Dimensions | Phoenix electrical | Phoenix hydraulic |
|-------------------------|-----------------------|-----------------------|
| Width | 68 cm/27" | 68 cm/27" |
| Depth | 112 cm/44" | 117 cm/46" |
| Seat height | 59 - 100 cm/23" - 39" | 59 - 100 cm/23" - 39" |
| Seat width | 54 cm/21" | 54 cm/21" |
| Seat depth | 43 cm/17" | 43 cm/17" |
| Body weight max. | 150 kg/330 lbs | 150 kg/330 lbs |
| Product weight | 53 kg/116 lbs | 52 kg/114 lbs |

Equipment

- Height adjustable, hydraulic or electric
- Adjustable PUR headrest
- Tilting adjustment
- Swinging armrests enable easy side transfer
- Soft PUR seat, back & leg support.
- 5" hospital grade swiveling and locking casters for secure transfers
- Height adjustable & removable footrests
- Seat with hygiene opening
- Approved up to 330 lbs body weight
- Five year warranty on frame for long lasting confidence
- Hygiene bucket with vacuum seal top included

Accessories

- Safety Belt, leg belt
- Safety Belt, for chest and waist
- Belt Comfort Pad
- Comfort headrest
- Arm rest
- Splash-Protection
- IV Pole

Art no

- 322.30.10
- 322.30.20
- 322.10.50
- 450.10.59
- 440.10.32
- 440.10.40
- 440.00.93



TR EQUIPMENT