



Powered Stair Climbing Hand Truck
Maintenance Manual



Table of Contents

A. Introduction.....	3
B. Diagram	4
1. Battery.....	5
2. Battery Clamp.....	7
3. Control Box.....	7
4. Crossbars	8
5. Drive Chain	9
6. Drive Motor	10
7. Electronic Card.....	11
8. Gray End Cap.....	15
9. Handles	16
10. Lifting Unit	16
11. Main Wiring Harness.....	17
12. Microswitch.....	20
13. Nose Plate.....	20
14. Round up Switch	21
15. Safety Flap	22
16. Small Gray Wheel.....	23
17. Swing Arm Assembly.....	24
18. Wheel.....	25
19. Wheel Bracket.....	27
20. Wheel Guard	27
22. Powered Stair Climber Warranty and Liability.....	30
23. Trouble-Shooting Directions	31
24. Maintenance Schedule.....	33
25. Schematics for Additional Reference.....	36

A. Introduction

Please read the Operator's Manual thoroughly to become familiar with the operation and controls of the Powered Stair Climber. The Powered Stair Climber has been designed specifically for serviceability so components can be easily replaced.

This Maintenance Manual contains:

- A troubleshooting guide
- Detailed directions to make each repair on your own
- Assembly drawings to help locate and describe parts
- A replacement parts list

The following are the tools needed to properly service the Powered Stair Climber:

- #1 Phillips screwdriver
- #2 Phillips screwdriver
- Flat screwdriver
- 3mm Allen wrench
- 5mm Allen wrench
- 6mm Allen wrench
- 8mm Allen wrench
- 13mm Allen wrench
- 7mm socket with ratchet
- 13mm socket with ratchet
- T-40 Torx® wrench
- T-30 Torx® wrench

We sincerely appreciate your purchase of this exciting product. We hope this manual is helpful. However, if you have questions please do not hesitate to call our customer service department at 1-800-MAGLINE (624-5463) or 989-512-1000.



Caution !

Never make repairs to your Powered Stair Climber while battery is inserted.

B. Diagram

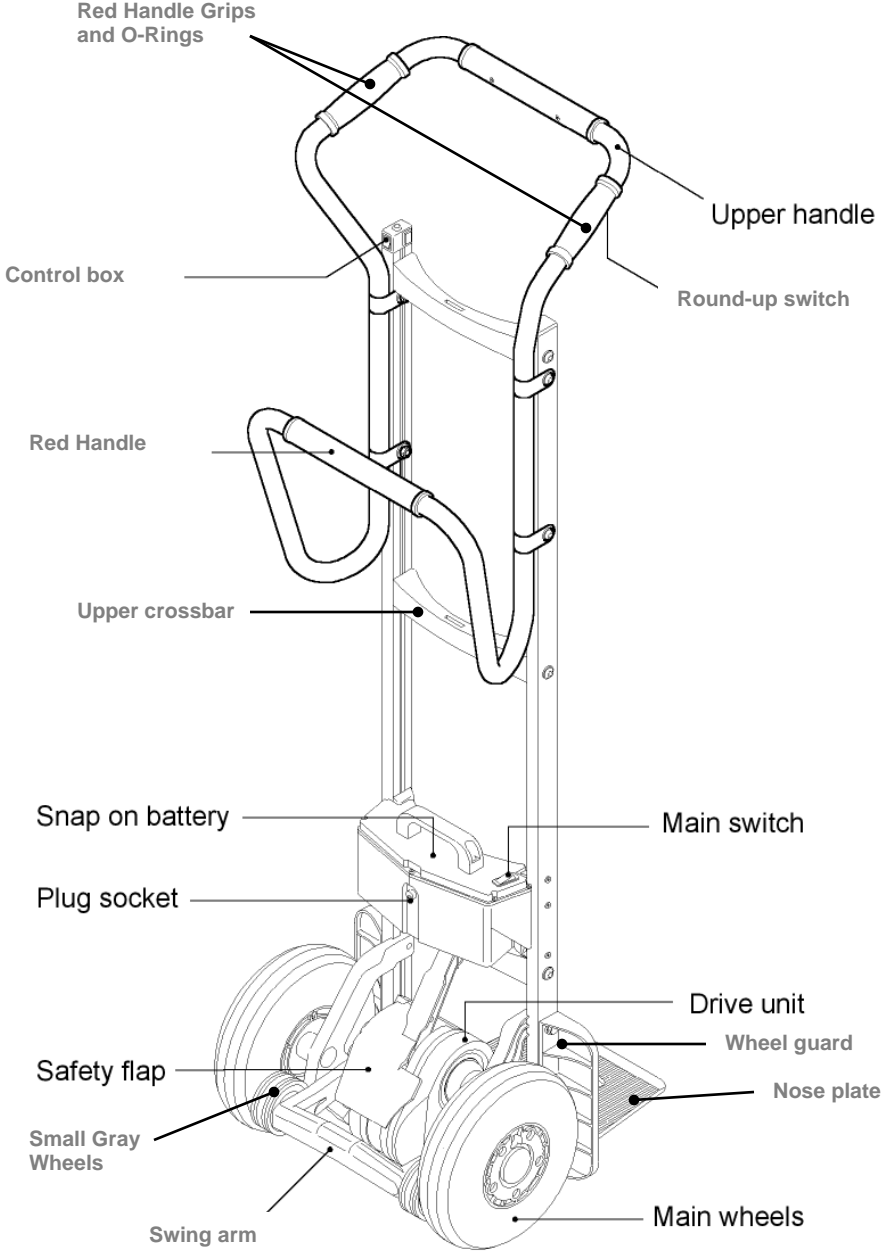

1. Battery

Make sure the battery is properly engaged into the spring-loaded battery clamps. Turn on the main switch.

Fig. 1a



Fig. 1b



Depress the ascend / descend button to initially turn on the Powered Stair Climber and to toggle between the ascending and descending modes. The green light should be on.

Fig. 1c



If not, the fuse (part number 004607) for the battery may need changing. Remove the battery cover by unscrewing the eight screws with a #1 Phillips screwdriver. Remove the fuse. Test the fuse for continuity with a MultiMeter or similar. If it reads OL (digital) or ∞ (analog), change the 30 Amp fuse by pulling the old one out by hand and inserting the new one.

Fig. 1d

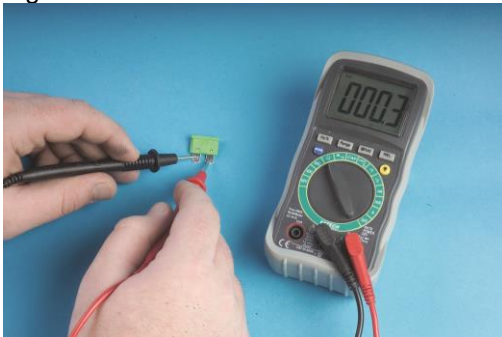
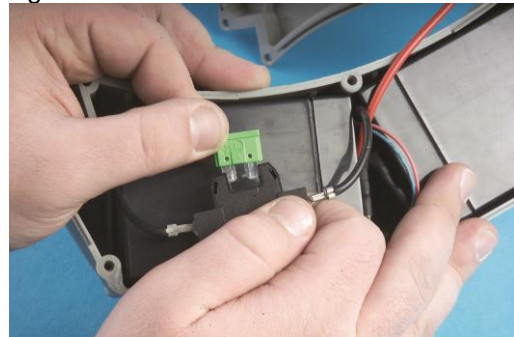
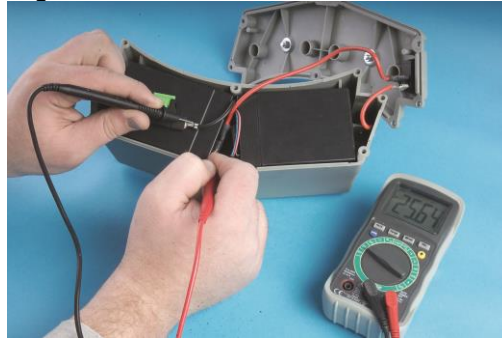

Fig. 1e



Test the battery pack for voltage with a MultiMeter or similar. A good battery should read 24-26 volts (VDC). If the MultiMeter reads 12-15 volts (VDC), one battery cell needs replacing. Check each cell separately to determine which battery cell needs replacing.

Fig. 1f





To replace battery cells, remove battery cover with a #1 Phillips screwdriver. Remove fuse and unplug top wires and tilt entire battery case 45 degrees to allow cells to gently fall out of case. Unplug bottom wires.

	Caution !
	Avoid touching battery contact points together.

Reconnect bottom wires into the new battery cells. Gently reposition into the battery case and reconnect the top wires. Use page 36 as a guide when reconnecting.

	Caution !
	Inserting a battery with reversed polarity on the Powered Stair Climber will cause a short circuit in the electronic card and may cause overheating and potential damage to the DC charger.

Before inserting this battery on your Powered Stair Climber, test the battery for reverse polarity by connecting your battery to a charger. Display will alternately blink  and  symbols to indicate reversed polarity. Correct polarity by ensuring the battery wires are connected exactly as shown on page 36.

2. Battery Clamp

Remove right battery clamp (part number 004120) and left battery clamp (part number 004121) by unscrewing the three screws in the side rail with a #1 Phillip screwdriver. If springs or locking clips are noticeably worn, replace the battery clamp.

Fig. 2a

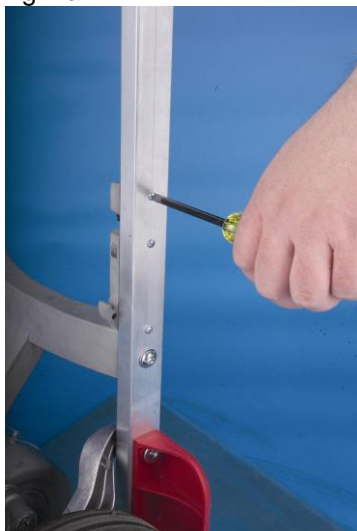
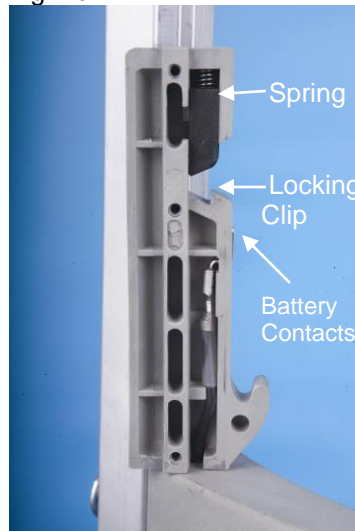

Fig. 2b



3. Control Box

To change the control box (part number 030220), remove the setscrew located on the inside of the Powered Stair Climber frame side rail using a #1 Phillips screwdriver. Gently pry the control box from the frame with a flat screw driver. Use both hands to disconnect the control box from the rest of the Powered Stair Climber wiring harness.

Fig. 3a



Fig. 3b



Fig. 3c



4. Crossbars

To replace top two crossbars (kit number 030024K) remove screws in side rails using a T-40 Torx wrench. Loosen RIGHT side of bottom crossbar with a T-40 Torx wrench. Gently tap the side rail with a soft rubber mallet to break the seal.

Fig. 4a

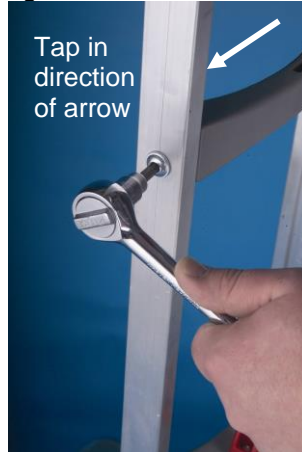

To replace the bottom cross bar (part number 030034), make sure the battery is not inserted. Unplug the main wiring harness from the control box (see Figure 3c), and then remove safety flap (see page 19), remove left wheel (see page 22), and remove right and left battery clamps (see page 7). Remove the red plastic cover on bottom of crossbar stabilizer arm by prying at the top in the middle with a small flat screwdriver, and then pry each side at the bottom. Be careful to not break the two small plastic nubs on the bottom.

Fig. 4b



Fig. 4c

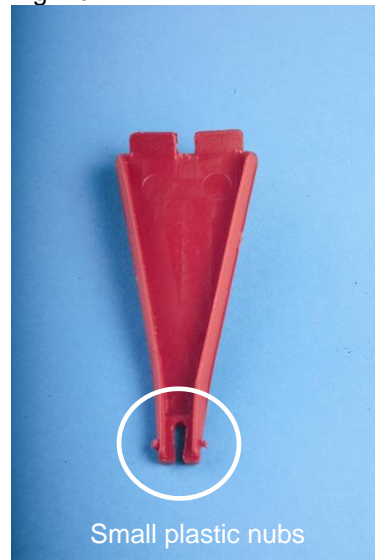

Remove screws in side rail with a T-40 Torx wrench. Lightly tap the RIGHT side (when standing behind Powered Stair Climber) of the side rail with a soft rubber mallet.

	Caution !
	Tapping the LEFT side of the side rail will damage the main wiring harness.

Fig. 4d



5. Drive Chain

Be sure battery is not inserted. To inspect the drive chain, remove the left wheel (see page 22) and safety flap (see page 19). Pop off and rotate the plastic safety cover out of the way with a flat screwdriver.

Fig. 5a

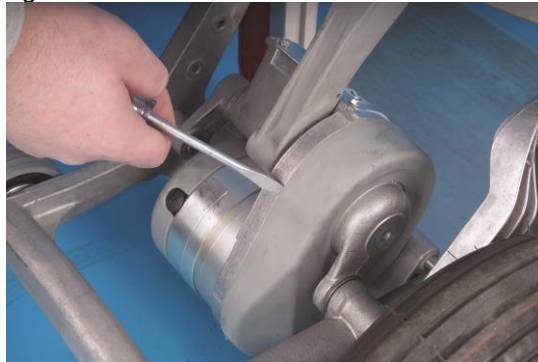

	Caution !
	Do not run Powered Stair Climber without the plastic safety cover securely in place.

Next, check the chain to ensure none of the links are broken. If necessary, replace the chain (part number 005627).

If links are broken, replace chain by disconnecting the connecting link. Remove old chain and put the new chain in place with a new connecting link.

Fig. 5b

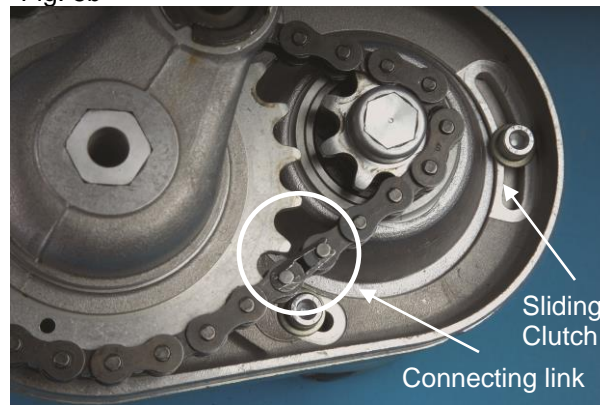

6. Drive Motor

With the battery in place, position the swing arm out of way so the bolts are easily reached. Then, remove the battery from the Powered Stair Climber so no power can get to the unit. To replace the drive motor*, remove both wheels (see page 22) and safety flap (see page 19).

Fig. 6a



- * Drive Motor part numbers:
 - 010123 for the SAL 110 model
 - 010124 for the SAL 140 model
 - 010137 for the SAL 170 model

Remove swing arm assembly (see page 21). Rotate the chain guard out of the way. Locate and remove the connecting link so chain comes off (see page 10). Using a 5mm Allen wrench, remove the three bolts that hold the motor on from the inside.

Fig. 6b



Find where the motor wires come in at the bottom of the main panel and disconnect at the splice. The drive motor should come off easily.

Fig. 6c

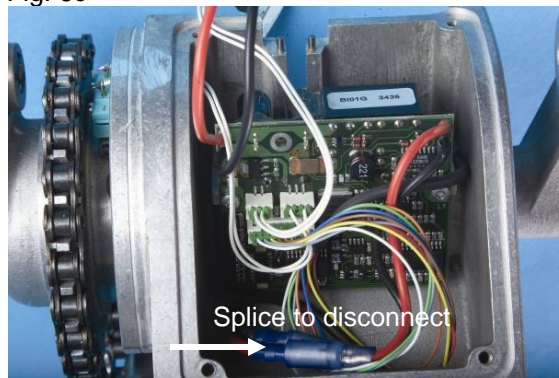

7. Electronic Card

Note – Powered Stair Climbers purchased AFTER December 2016 have the 0051491 electronic card and appropriate housing for the card and DO NOT need the adapter kit spacer or extra wiring harness. Use these adapter items when replacing the electronic card in Powered Stair Climbers purchased BEFORE December 2016.

Models Purchased AFTER December 2016

To replace the electronic card (part number 0051491) remove four bolts on the aluminum motor cover with a 7mm socket with ratchet. Since removing this cover breaks the silicone seal, scrape off old silicone and apply new silicone when reassembling.

Fig. 7.1a

Fig. 7.1b

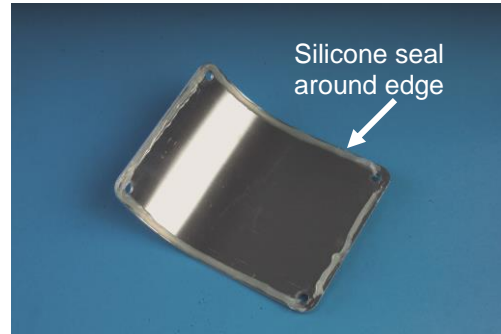

Carefully remove the electronic card by unscrewing the two screws in the aluminum plate that attaches to the circuit board with a 3mm Allen wrench. Note the location of connections and arrangement of all wires for reassembly. Disconnect wires and remove electronic card by gently prying each side of the electronic card up with a small flat screwdriver. Reconnect wires to the new electronic card and reposition.

Fig. 7.1c

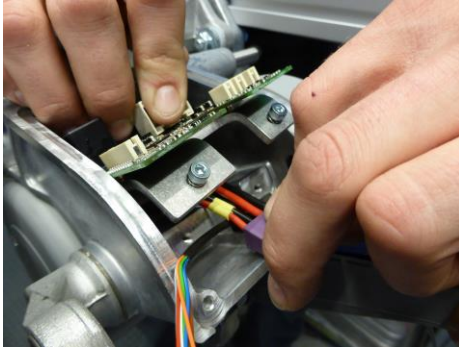

Fig. 7.1d



Models Purchased BEFORE December 2016

To replace the electronic card (part number 0051491) remove four bolts on the aluminum motor cover with a 7mm socket with ratchet. Since removing this cover breaks the silicone seal, scrape off old silicone and apply new silicone when reassembling. See figures 7a and 7 b above.

Carefully remove the electronic card by unscrewing the 2 screws in the aluminum plate that attaches to the circuit board with a 3mm Allen wrench. Mount the aluminum adapter inside the motor power control housing using the countersunk-head screws provided in the kit.

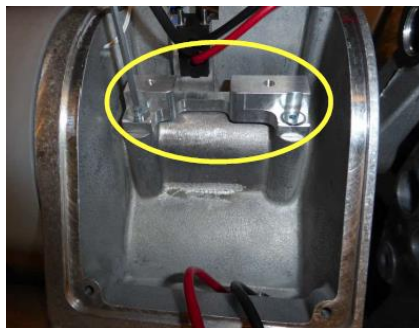

Fig. 7.2a

Connect the adapter cable with the cable harness of the machine as shown in the following pictures.

Fig. 7.2b

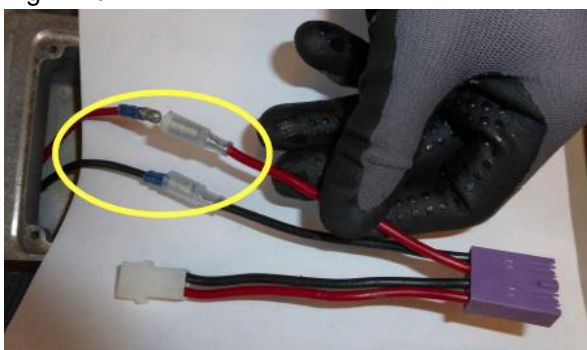
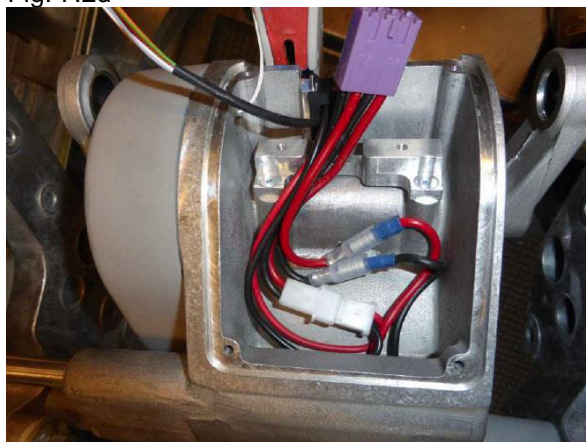

Fig. 7.2c



Fig. 7.2d



Assemble the electronic card to the aluminum adapter, using the two screws previously removed from damaged electronic card.

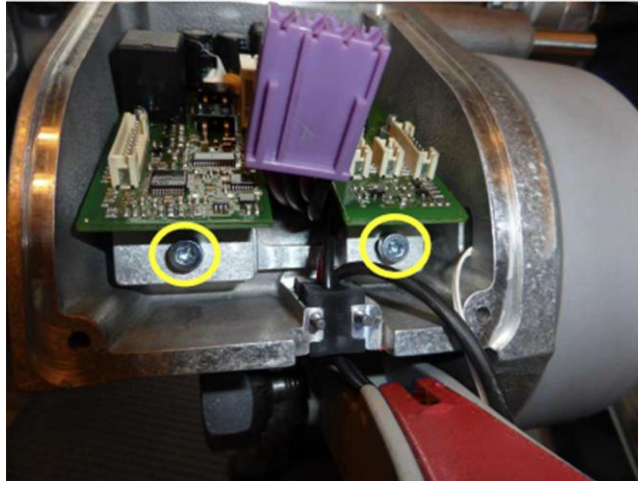

Fig. 7.2e

Connect the cabling with the motor power control assembly (MESAL, p/n 0051491) as shown in the following pictures.

Fig. 7.2f



Fig. 7.2g

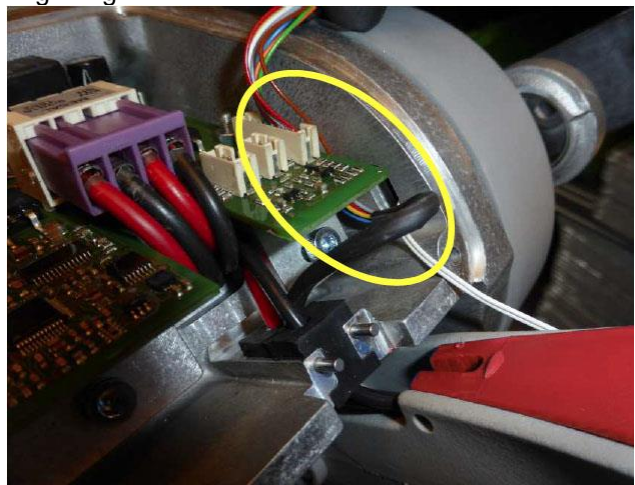

Fig. 7.2h



Fig. 7.2i

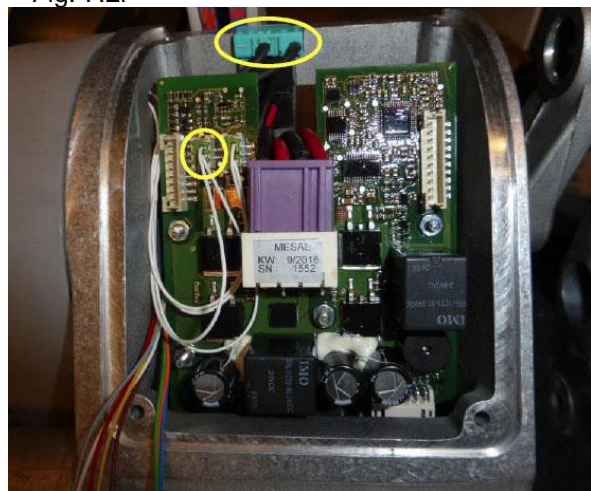

Fig. 7.2j



After arranging the cables as shown above, apply new silicone to the aluminum cover and reinstall the cover (see Figures 7.1a through 7.1d).

8. Gray End Cap

To replace gray end cap (part number 030023) use flat screwdriver to pry the end cap out of side rail. Push new one into side rail.

Fig. 8



9. Handles

To replace red handles (see pages 39-41 for part numbers) pull out and unplug the round up switch (see page 18). Then, remove the screws in the red handle with a #2 screwdriver.

Fig. 9

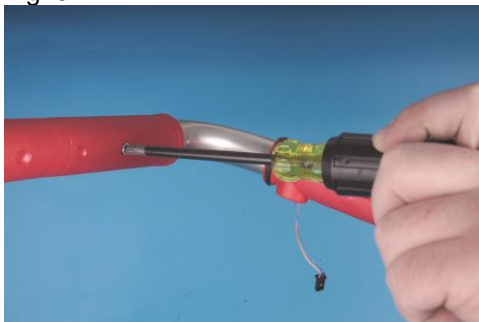

Remove the right handle bracket screw (see Fig. 8 on page 12) with a T-30 Torx wrench. Pull handle apart while being careful to not damage the main wiring harness that runs to the round-up switch. Remove old red plastic handles and cut off old O-rings. Roll new O-rings over top and position into grooves on new handles. A curved hook may be useful to stretch and pull the new O-rings over the new handles.

10. Lifting Unit

With the battery in place, position the swing arm out of way so the bolts are easily reached (see Fig. 6a). Then, remove the battery from the Powered Stair Climber so no power can get to the unit.

To replace the lifting unit*, remove both wheels (see page 22) and remove safety flap (see page 19). Remove thru rod with 13mm socket wrench, using a second wrench to hold the other end in place while loosening.

Fig. 10a



* Lifting Unit part numbers:

-005133 for the SAL 110 model

-005134 for the SAL 140 model

-005146 for the SAL 170 model

Remove the aluminum motor cover with a 7mm socket wrench (see Fig. 7a). Since removing this cover breaks the silicone seal, scrape off old silicone and apply new silicone when reassembling. Unhook the main wiring harness from the electronic card (see Fig. 11d). Pull out both grommets that run the wires through to the electronic card by working side to side.

Fig. 10b



11. Main Wiring Harness

Be sure the battery is removed. To replace the main wiring harness (part number 030126); remove the control box (see page 7). It is not necessary to remove red handles and O-rings. Disconnect the wires to the round up switch at the connector (see page 18). Cut off both connectors leaving approximately 1" of wires for a guide when connecting for reassembly.

Fig. 11a

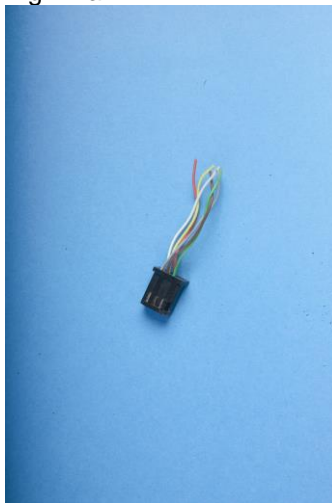

Remove handle brackets to the frame with a T-40 Torx wrench. Remove handle and gently pull the wires through.

Fig. 11b



Remove nose plate (see page 17). Remove wheels (see page 22). Remove all screws in the left, side rail. Remove left wheel guard (see page 24). Remove both wheel brackets (see page 24). Remove left battery clamp (see page 7). Remove safety flap (see page 19). Carefully pull wires one at a time through the frame at the hole above the wheels and remove the side rail.

Fig. 11c



Remove aluminum motor cover (see Fig. 7a on page 11). Since removing this cover breaks the silicone seal, scrape off old silicone and apply new silicone when reassembling.



Caution !

Notice the position of the wires under the aluminum motor cover for reassembly.

Unhook the main wiring harness from the electronic card. In Fig. 11e, the main wiring harness is the plug that has all the colored wires. The green plastic plug will unhook from the white plastic terminal. Do not unplug by pulling on the wires as this will damage the wires. If necessary, gently pry the green plug loose using a flat screwdriver.

Fig. 11d

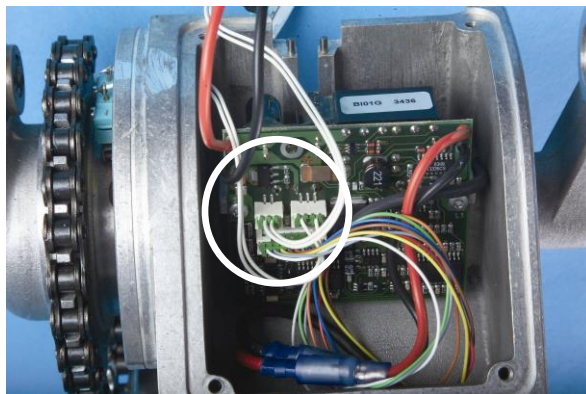
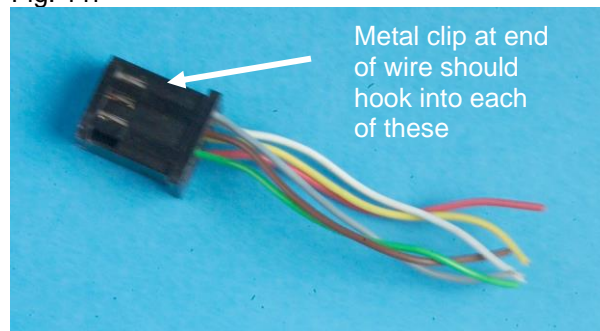

Fig. 11e



To begin reassembly of the main wiring harness, twist the orange and blue wires that run to the round up switch together. Then, twist the remaining wires to the orange and blue wires and pull the new wiring harness through the lower hole in the frame near the circuit board with a 40 inch wire hook. Be careful to not strip the wire coating while pulling wires through. Reconnect wires at all connections. Unhook the old wires and re-hook the new wires one at a time into the connector according to the 1" guide that was kept earlier. Be sure the metal clip hooks in properly. Reverse assembly.

Fig. 11f



12. Microswitch

To inspect the microswitch (part number 005136), be sure battery is removed from your Powered Stair Climber. Remove aluminum motor cover (see Fig. 7a on page 11). Since removing this cover breaks the silicone seal, scrape off old silicone and apply new silicone when reassembling.

The microswitch should make a soft clicking sound when depressed. To inspect the microswitch, use an Ohm Meter. It should read near 0.4 when depressed. Notice proper direction / location of microswitch for reassembly.

	<p>Caution ! If installed backward, damage to the microswitch will result.</p>
---	---

Fig. 12a

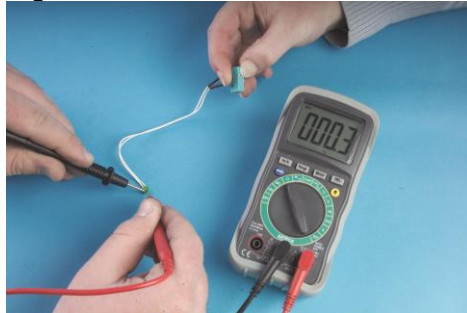

Fig. 12b



13. Nose Plate

To change the nose plate, loosen the three screws on the bottom of the nose using a T-40 Torx wrench. For Powered Stair Climbers purchased prior to 2004, use a 5mm Allen wrench to loosen screws. For reassembly, note the longer screw goes in the middle.

Fig. 13



14. Round up Switch

Be sure battery is removed from unit so no power goes to the Powered Stair Climber. Remove the round up switch (part number 030148) by popping out of handle hole with a flat screwdriver. Unplug the switch from the main wiring harness.

Fig. 14a

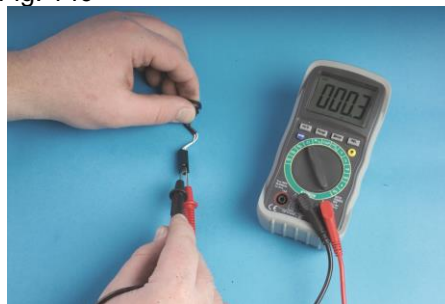

Fig. 14b



Test the round up switch with a MultiMeter by touching each prong to each connection. When button is not depressed, the display should read OL (digital) or ∞ (analog). Depress the button and the display should read near 0.3. If it reads OL when the button is depressed, replace the round up switch.

Fig. 14c



To reassemble, hook wires into the new switch and push back into place.

15. Safety Flap

To inspect the safety flap (part number 005025), remove the left wheel, when standing behind the unit (see page 22). Pry the black cap off with a flat screw driver. Using an 8mm Allen wrench, remove the bolt holding the safety flap in place.

Fig. 15a



Fig. 15b

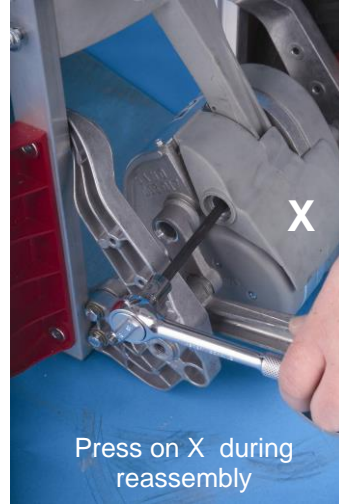

Apply anti-seize grease to the safety flap shaft before reassembly (see Fig. 15c). The spring must be “loaded” prior to assembly. When spring is loaded, the safety flap spring will rest directly on motor. To ensure spring is loaded, firmly hold safety flap against motor housing by pressing on bottom left corner while tightening (see Fig. 15b). This will create the gap required during assembly to prevent damage to the microswitch.

Fig. 15c



Fig. 15d

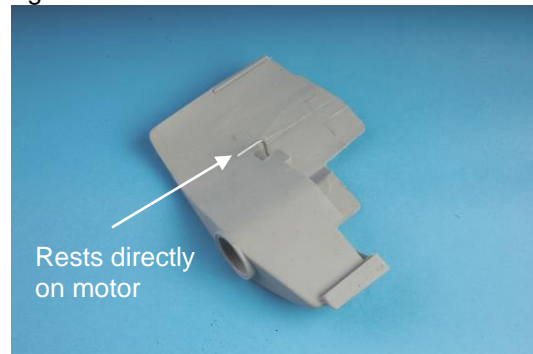

If safety flap shaft has some corrosion, clean with 320 grit emery cloth. If safety flap shaft is corroded beyond cleaning as shown on the right in Fig. 15e, replace.

Fig. 15e



16. Small Gray Wheel

To replace the small gray wheel (part number 005120) on the support arm, remove bolt with a 3mm Allen wrench. The outer assembly of the small gray wheel will pull right off.

Fig. 16a



Remove the bearing assembly with snap ring pliers by inserting the tips of the pliers into the 2 holes of the snap ring. Expand and pull off the snap ring so it hangs loosely. Pull assembly off carefully as there are three small pins and three small springs that fall loose when this assembly is removed.

Fig. 16b



Apply anti seize grease to bearing flange and locking bolt. Position as shown below for reassembly. Place a quarter inch wide piece of masking tape on the bottom portion to hold pins and springs in place while sliding bearing assembly over the small pins and small springs. Be sure to remove tape before operating your Powered Stair Climber. Use snap ring pliers to put snap ring back on.

Fig. 16c

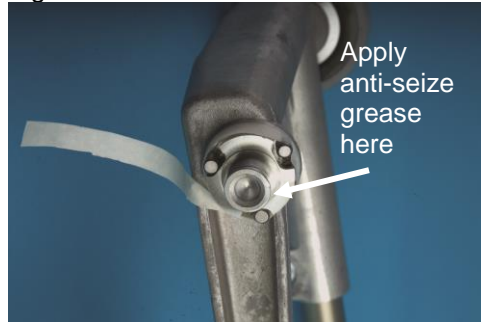

Lock bearing housing in place by inserting a 2.5mm Allen wrench in the hole and rotate until nestled against the lift arm. This will keep wheels from rotating while tightening. The wheels should spin freely one way only. Reposition outer assembly over inner assembly and tighten the screw with a 3mm Allen wrench.

Fig. 16d



17. Swing Arm Assembly

With the battery in place, position the swing arm out of way so the bolts are easily reached (see Fig. 6a on page 10). Then, be sure to remove the battery from the Powered Stair Climber so no power can get to the unit.

To replace the swing arm assembly (part number 005127), remove both wheels (see page 22). Remove safety flap (see page 19). Remove bolt on left side of swing arm where it attaches to the bracket with a 5mm Allen wrench. Remove bolt on right side of swing arm with a 6mm Allen wrench.

Fig. 17a



Fig. 17b



Unscrew so it is secured by approximately three threads only. Gently pound on the head of the screw with a hammer to move the bushing out just enough to move the swing arm. Repeat on the other side. Work swing arm assembly back and forth to remove. To change oil, remove piston rod and drain oil completely; replace with 1.75 ounces of SAE 90W Gear Lube.



Caution !

When removing piston rod, do so carefully because oil will flow out once removed.

18. Wheel

To change a flat tire, use a flat screwdriver to pop off the black plastic wheel cap. Then, use an 8mm Allen wrench to remove the shoulder bolt.

Fig. 18a



Fig. 18b



When the bolt is removed, pull off the tire by hand. Next make certain all air pressure is released and disassemble the wheel hub using an 8mm socket wrench, noting the location of each bearing and the bushing. Split the hub. Once the hub is split, remove each side of the hub and remove the damaged inner tube. Insert the new tube into the tire.

Fig. 18c



Fig 18d



Then, replace the plastic hubs making sure both grooves for the valve stem are lined up properly.

Fig. 18e



Inflate the tire to 50 psi.

Before reattaching the wheel, apply a thin film of anti-seize grease to the 1/8 inch lip on the mounting flange.

Fig. 18f



19. Wheel Bracket

Remove wheel (see page 22) and wheel guard (see below) on the same side as the wheel bracket (part number 030037) you are replacing. Remove nose plate (see page 17). Remove thru rod with a 13mm Allen wrench. Remove 2 bolts on nose plate bracket with a 13mm Allen wrench using a second wrench at the other end to hold in place while loosening. Gently tap out of place with a soft rubber mallet.

Fig. 19



For reassembly, loosely attach the wheel guard. Put the 2 bolts that connect the wheel bracket to the nose plate bracket back in place. Insert the thru rod and tighten completely. Tighten the wheel guard in place. Reattach nose.

20. Wheel Guard

To replace the wheel guard (part number 030077), remove wheel (see page 22) on the same side as the wheel guard you are replacing to allow access. Remove the wheel guard with a 13mm socket wrench.

Fig. 20



21. Replacement Parts List

Description	Part #
Service Kit	
Dealer Service Kit - <i>includes Crossbar Kit, Noseplate Kit, Round "Up" Switch, and Red Control Switch.</i>	030000K
Frames	
Center Strap	930105
Middle Bar Support, Flush Frame	930133
Cross Bar Kit (includes hardware)	030024K
Bottom Cross Bar/motor stabilizer arm	030034
Side rail, Left	030014
Gray End Cap for Side Rail	030023
Side rail, Right	030030
Handles	
Red Ergo Handle Complete	030240
Red Uni Handle Complete	030238
Countersunk head screw M4x8 (for plastic grips)	030627
Red Plastic Ergo and Folding handle grip (LH), bottom	030083
Red Plastic Ergo and Folding handle grip (RH, control), bottom	030081
Top Red Ergo and Uni Handle w/o O-Rings	030082
Top Red Uni Handle with Round up Switch Hole	030079
Ergo Handle (right side) w/o red grips	030008
Ergo Handle (left side) w/o red grips	030010
Uni Handle (right side) w/o red grips	030016
Uni Handle (left side) w/o red grips	030018
Folding Handle w/o red grips	030146
O-Ring	030060
Nose Plates	
Bracket, Noseplate Mounting Kit, Fixed	930104K
Noseplate WL 14" x 7"	930018
Noseplate GS 18.8" x 9.4"	930030
Noseplate GS-NG (no grooves) 18.74" x 9.4"	930084
Noseplate NG 17.7" x 7.5"	930085
Noseplate G 16.5" x 13.4"	930003
Noseplate LH 18.4" x 10.9"	930002
Noseplate Bolt Kit	030634K
Wheels	
1-Puncture Proof Wheel	930148
1-Red Hub 4-ply Pneumatic Wheel	030245
Tube only (used with Powered Stair Climber wheels)	121060T
Wheel Bearing	030642

Black Wheel Cap	030640
Small Grey Wheel	005121
Small wheel hardware pack	005638K
Shoulder Bolt Axle	030645
Red Wheel Guard - <i>each</i>	030077
Right wheel bracket	030036
Left wheel bracket	030037
Securing Devices	
1" x 56" Strap with buckle	930006
1" x 100" Strap with buckle	930007
Keg Hook	930108
Electrical - Powered Stair Climber Battery Parts	
Complete Powered Stair Climber Battery	004210
Battery cell (each); 12v gel cell	004604
Battery Cover Grey	004012
Lower Battery Housing	004011
Handle for battery unit red	004617
Bolt M5x20 (holds the battery handle on)	004611
Washer M5	004612
Hexagon nut M5	004613
Screw 04x16 (secures the battery cover to the housing)	004614
Fuse holder	004606
Main Switch	004608
Battery Fuse	004607
Positive Lead	004122
Negative Lead	004123
Battery Harness	004129
Lower Battery Case Assembly	004233
Electrical - Powered Stair Climber Chargers	
Battery Holder with DC Charger, Powered Stair Climber	930114
AC Battery Charger Kit with bag	930602
Cable and plug adapter for USA, AC charger	930624
Charging cable for Sal (w/white clip), output	930124
In-Transit DC Battery Charger - <i>less battery holder</i>	930600
Left hand Battery Clamp complete, Powered Stair Climber	004121
Right hand Battery Clamp complete, Powered Stair Climber	004120
Electrical - Switches	030148
Round Up Switch	030126
Main Wiring Harness	030615
Red Control Box	030220
Electronic Card	0051491
Microswitch	005136

Motor Components	
Motor Safety Cover	005025
Motor mount bushing - 27mm	005028
Drive Motor Sal 110	010123
Drive Motor Sal 140	010124
Drive Motor Sal 170	010137
Motor Safety Cover Spring, Powered Stair Climber	005033
Rod, lifting unit mount	030132
Lifting Unit Sal 110	005133
Lifting Unit Sal 140	005134
Lifting Unit Sal 170	005146
Drive Chain	005627
Bushing, Pivot Shaft	005610
Bushing, LH Motor Mount	005027
Black Plastic Cap for Safety Flap	005632
Safety Flap Shaft	005031
Nut M8, motor mount	005611

22. Powered Stair Climber Warranty and Liability

Warranty

The warranty period for the Powered Stair Climber is 12 months (6 months for batteries) from the date of purchase and covers defective material and production faults.

Warranty exclusions are:

- Normal wear and tear on parts
- Damage resulting from abnormal load
- Damage due to the exertion of force
- Modifications to the Powered Stair Climber or its accessories

Liability

Magline Inc. as distributor of the Powered Stair Climber is not responsible for the safety of the Powered Stair Climber if:

- The Powered Stair Climber is used for purposes other than those for which it is intended
- The Powered Stair Climber is not regularly maintained properly by a mechanical workshop
- The instructions in the operator manual are not observed
- Non-original parts are installed or connected to the Powered Stair Climber
- Original parts are removed

23. Trouble-Shooting Directions

23.1 My Powered Stair Climber does not turn on

- A. Is the main switch turned on (see Fig. 1b on page 5)?
- B. Is the battery charged? When charging with DC charger (part number 930114), be sure the main switch on battery is in the on position.
- C. Is the battery in complete contact with the spring-loaded battery clamp? Disengage and re-engage the battery to be sure (see Fig. 1a on page 5).
- D. Are the battery contacts and springs clean?
- E. Has the ascend / descend button been pressed once, displaying a solid green indicator light? (see Fig. 1c on page 5)
- F. Have you depressed the round up switch?
- G. Inspect the fuse located inside the battery box. Does it look blown? Replace with part number 004607 (see page 5).
- H. Inspect the control box. If it appears damaged, replace with part number 030220 (see page 7).
- I. Inspect the electronic card for any water or cracks (see page 11).

For more assistance, call Magline customer service at 1-800-MAGLINE (624-5463).

23.2 My Powered Stair Climber turns on, but will not run

- A. Is the battery charged? When charging with DC charger (part number 930114), be sure the main switch on battery is in the on position (see Fig. 1b on page 5).
- B. Is the green indicator light blinking? If so, the descend mode is active making the ascend button inoperable. Press ascend / descend button again for climbing mode, which is indicated by a solid green indicator light.
- C. Have you depressed the round up switch? It may be unplugged inside the main wiring harness (see Fig. 14b on page 18).
- D. Inspect the control box. If it appears damaged, replace with part number 030220 (see page 7).
- E. Inspect the safety flap shaft (part number 005031) for any corrosion. If corroded beyond cleaning, replace (see Fig. 15e on page 20).
- F. Check the safety flap and microswitch by depressing the bottom left side with your foot. A soft click should be heard when the safety flap is depressed. If the click is not heard, it may be necessary to inspect the spring located inside the safety flap (see page 9).

If the motor can be heard running but the swing arm with support wheels does not move, inspect the drive chain (see page 9). If the drive chain is in place, then the sliding clutch must be re-adjusted. (see Fig. 5b on page 10)

23.3 My Powered Stair Climber Will Not Lift Full Capacity

- A. Charge the battery fully. When charging with DC charger (part number 930114), be sure the main switch on battery is in the on position (see Fig. 1b on page 5).
- B. Be sure no more than capacity is loaded on the Powered Stair Climber.
- C. Make sure the battery contacts on both the Powered Stair Climber and the battery (part numbers 004120 & 004121) are clean. It may be necessary to replace if corroded beyond what can be cleaned.
- D. Check battery voltage with an Ohm Meter. (see page 5)

23.4 My Powered Stair Climber Runs Very Slow

- A. Charge the battery fully. When charging with DC charger (part number 930114), be sure the main switch on battery is in the on position (see Fig. 1b on page 5).
- B. Make sure the speed switch on the control box is switched to “fast” speed, which is indicated by two solid parallel lines.

If you toggle between slow (one solid line) and fast (two solid lines) and there is no difference in speed, pull out the control box and test with an Ohm Meter by removing control box and popping out toggle speed switch with a flat screwdriver. Place one prong on each of the two wires. If reading is OL, replace the control box (see page 7). If reading is not OL, replace main wiring harness.

24. Maintenance Schedule

The following section is the recommended maintenance for your Powered Stair Climber. Directions to complete each individual task can be found on the page indicated.

Magline would be happy to do this maintenance. Call our customer service department at 1-800-MAGLINE (624-5463) or (989) 512-1000 for more information.

24.1 Every Six Month Recommended Maintenance

Date Complete	Page #	Part #	Task
	8	030024K	Replace any cracked crossbars.
	17		Apply thin film of anti-seize to threads of nose bolts.
	22		Remove wheels and apply thin film of anti-seize to mounting flange.
	22	030640	Replace hub caps on wheels if missing.
	22		Verify air pressure in tires is correct. Inflate tire to 50 psi
	12	030023	Replace gray end caps on top and bottom of side rails if missing.
	11		Remove aluminum motor cover and inspect motor to ensure it's dry.
	20		Inspect small gray wheels for proper rotation. Should freely spin forward only.
	7		Replace right and left battery clamp if necessary. (004120 and 004121)
	5	004233	Replace battery housing if needed.
	19		Inspect safety flap shaft for oxidization.
	20		Clean with 320 grit emery cloth if needed.
	19		Apply anti-seize grease to exterior of safety flap shaft before reassembly.
	19	005632	Replace black plastic cap for safety flap if missing.
	5		Charge battery and check voltage of cells. Record results.
	33-36		Apply electrical grease.

24.2 Eighteen Month Recommended Maintenance

Date Completed	Page #	Part #	Tasks
	17		Apply thin film of anti-seize to threads of nose bolts.
	22		Remove wheels and apply thin film of anti-seize to mounting flange.
	22		Verify air pressure in wheels is correct. Inflate to 50 psi
	22	030640	Replace hub caps if missing.
	8	30024K	Replace any cracked crossbars.
	12	030023	Replace gray end caps on top and bottom of side rails if missing.
	11		Remove aluminum motor cover and inspect motor to ensure it's dry.
	20		Replace and inspect small gray wheels for proper rotation. Should freely spin forward only.
	7	004120	Inspect right and left battery clamp and replace if necessary. (004120 and 004121)
	21		Remove swing arm assembly and shaft, drain and replace oil (1.75 ounces of SAE 90W Gear Lube).
	5	004011	Replace lower battery housing if clips are worn.
	19		Inspect safety flap shaft for oxidization.
	20		Clean with 320 grit emery cloth if needed.
	19		Apply anti-seize grease to outside of safety flap shaft before placing back in position.
	19	005632	Replace black plastic cap for safety flap if missing.
	5		Charge battery and check voltage of cells and record results.
	33-36		Apply electrical grease.

24.3 Thirty Month Recommended Maintenance

Date Completed	Page #	Part #	Tasks
	17		Apply thin film of anti-seize to threads of nose bolts.
	22		Remove wheels and apply thin film of anti-seize to mounting flange.
	17	930030	Replace nose.
	12	030023	Replace gray end cap on top of side rails if missing.
	8	30024K	Replace any cracked crossbars.
	14	030126	Replace main wiring harness.
	18	030148	Replace round up switch.
	7	004120	Replace right and left battery clamps. (004120 and 004121)
	5	004011	Replace battery housing.
	19		Replace safety flap, safety flap shaft, and black plastic cap for safety flap.
	19	005025	Safety flap
	19	005031	Safety flap shaft
	19	005632	Black plastic cap for safety flap
	16	005136	Replace microswitch.
	5	004604	Replace battery cells.
	5		Charge battery and check voltage of cells and record results.
	33-36		Apply electrical grease.

Additional maintenance for heavy usage:

Date Completed	Page #	Part #	Tasks
	21	005127	Replace swing arm assembly.
	13	030082	Replace top and bottom red handles using new O-rings and screws.
	13	030060	O-ring
	13	030627	Screw
	22	930148	Replace wheels.
	11		Remove aluminum motor cover and inspect motor to ensure it's dry.
	13	005146	Replace lifting unit. (005133 or 005134 or 005146)
	10	010137	Replace drive motor. (010123, 010124, or 010137)
	7	030220	Replace control box.

25. Schematics for Additional Reference

Assembly drawings in this section are for reference only and should not be used to modify any original Magliner equipment. Drawings may not be to scale.

25.1 Battery

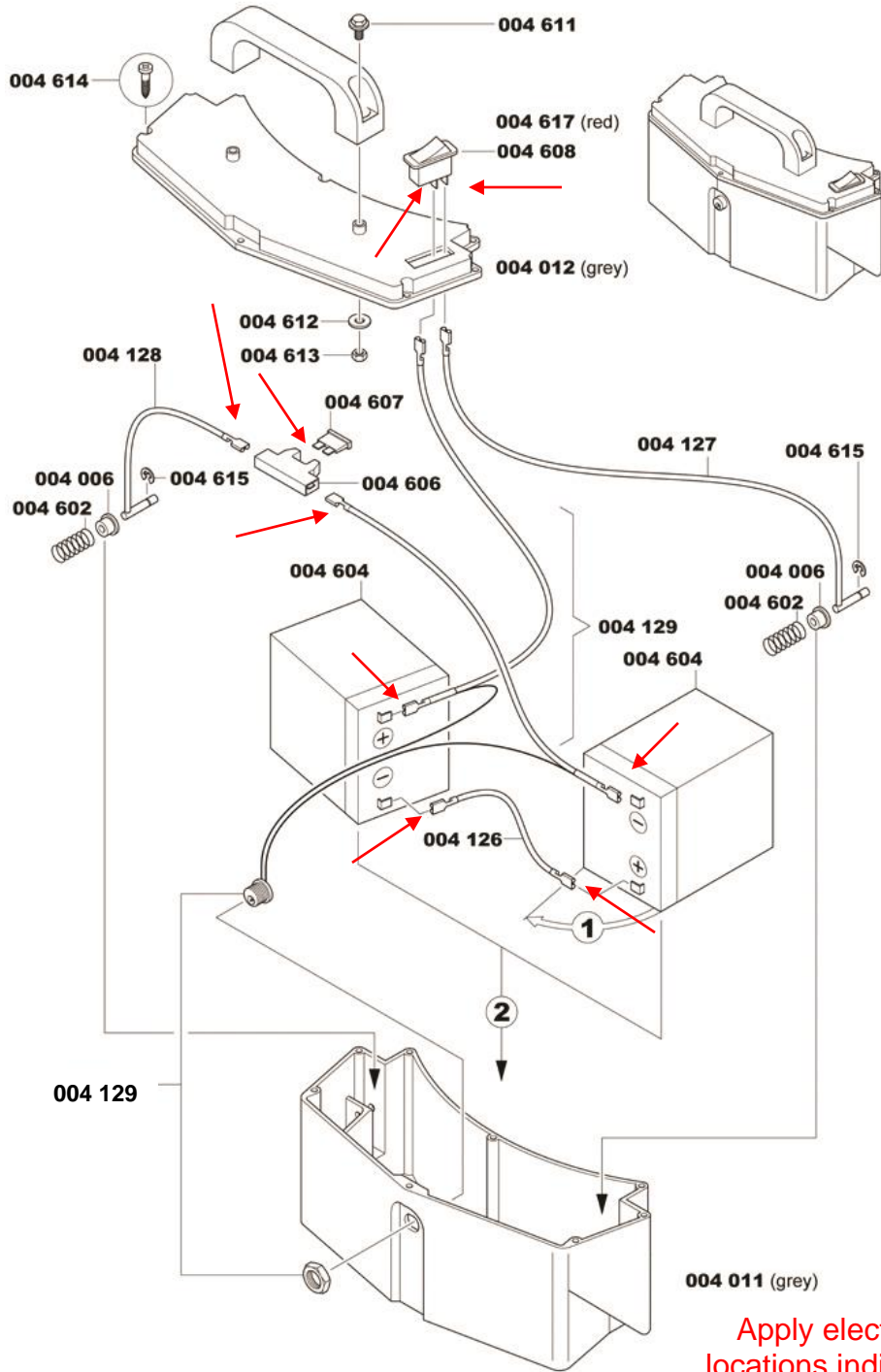

Apply electrical grease to the locations indicated by red arrows.

25.2 Electrical Components- Ergo

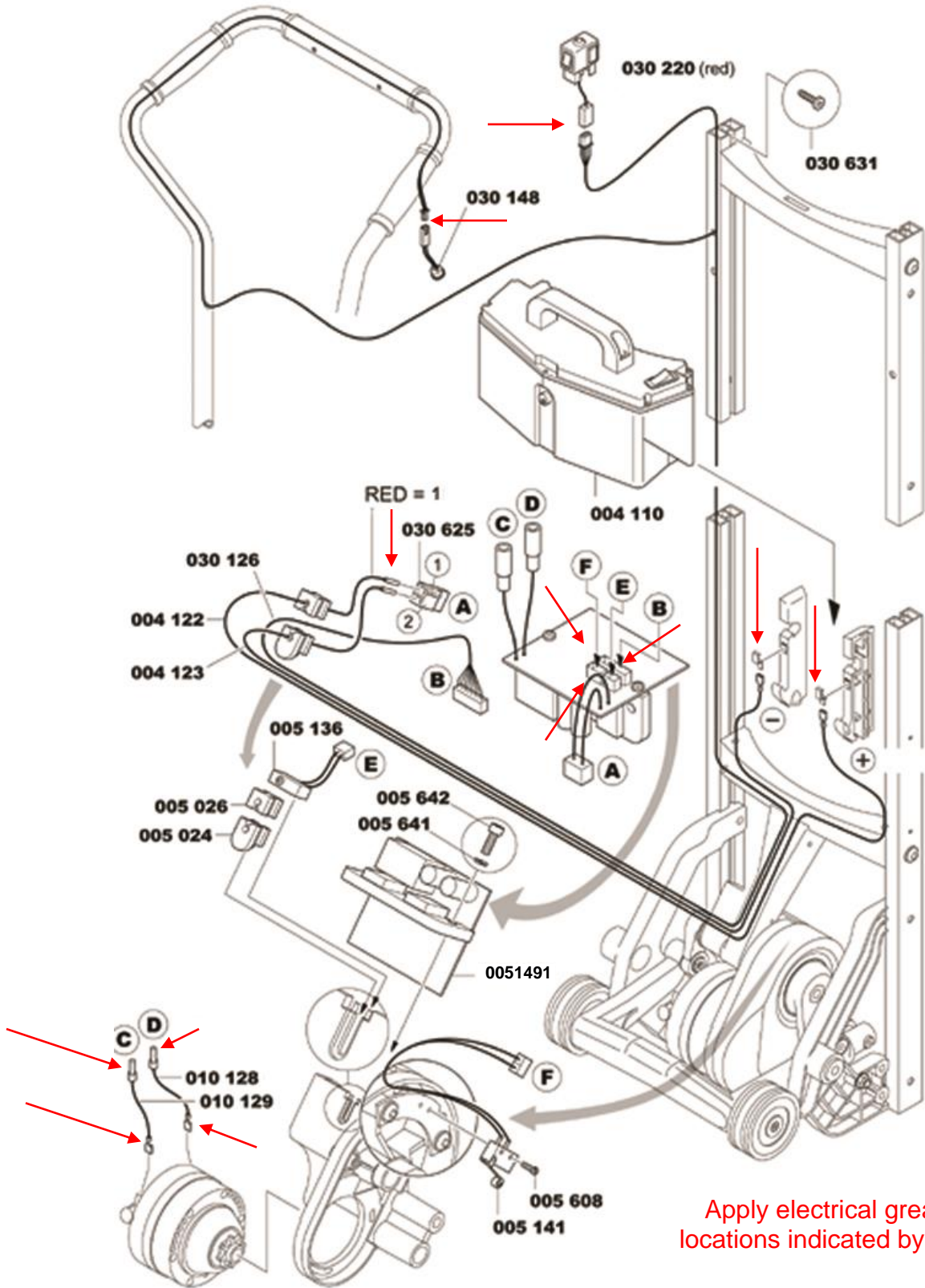

Apply electrical grease to the locations indicated by red arrows.

25.3 Electrical Components- Folding

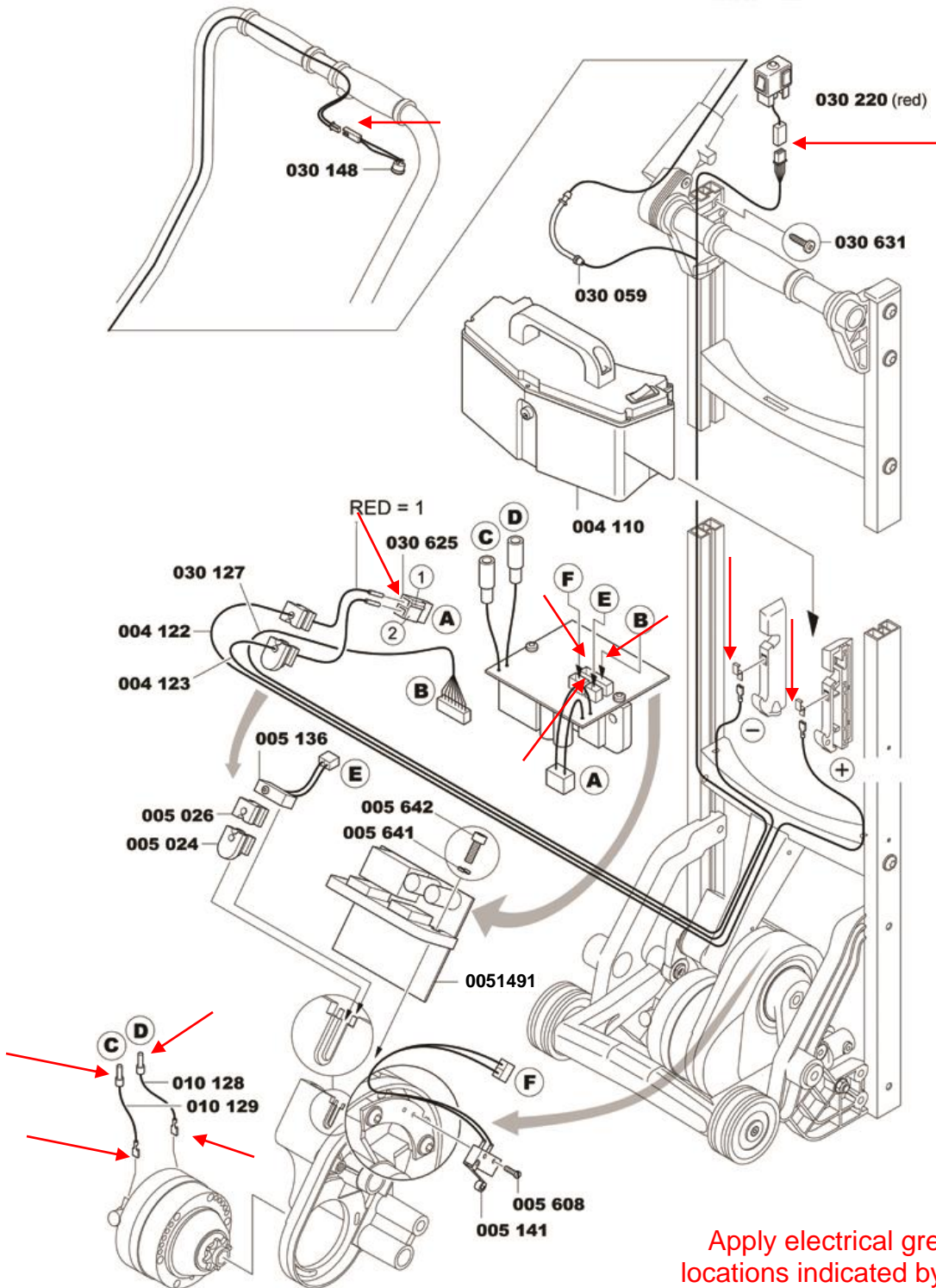

25.4 Electrical Components- Uni

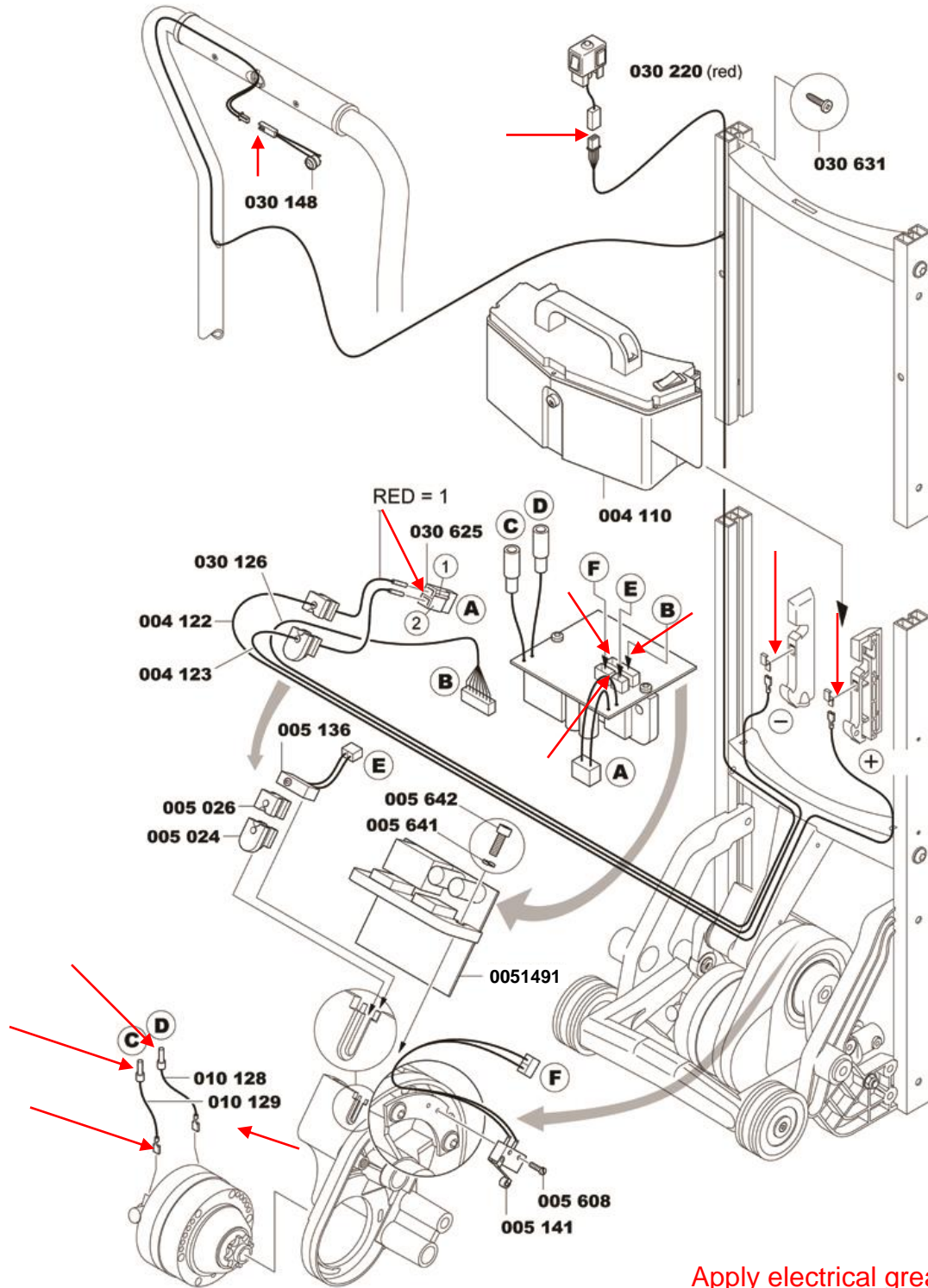

Apply electrical grease to the locations indicated by red arrows.

25.6 Frame- Folding

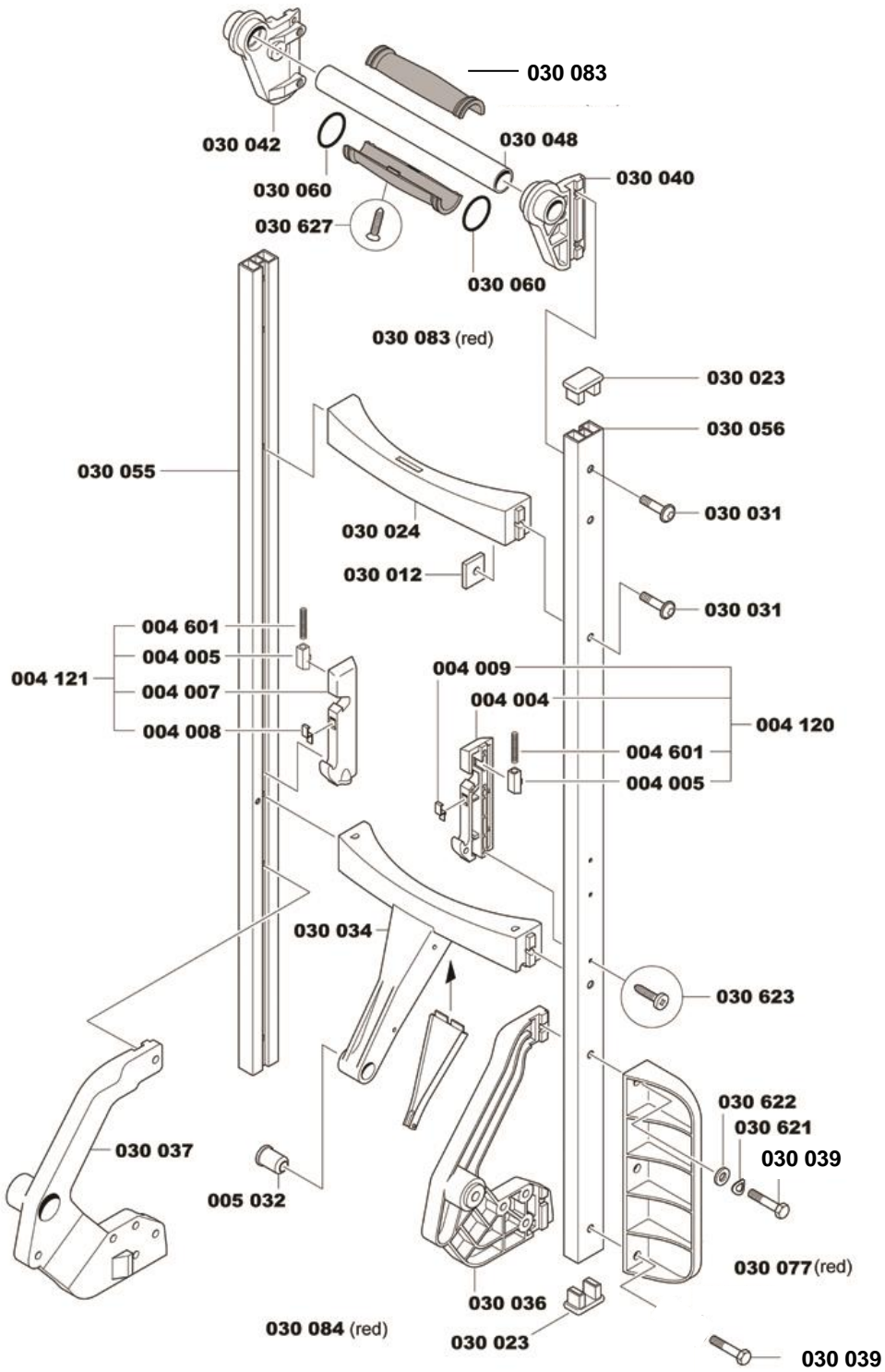

25.7 Handle- Ergo

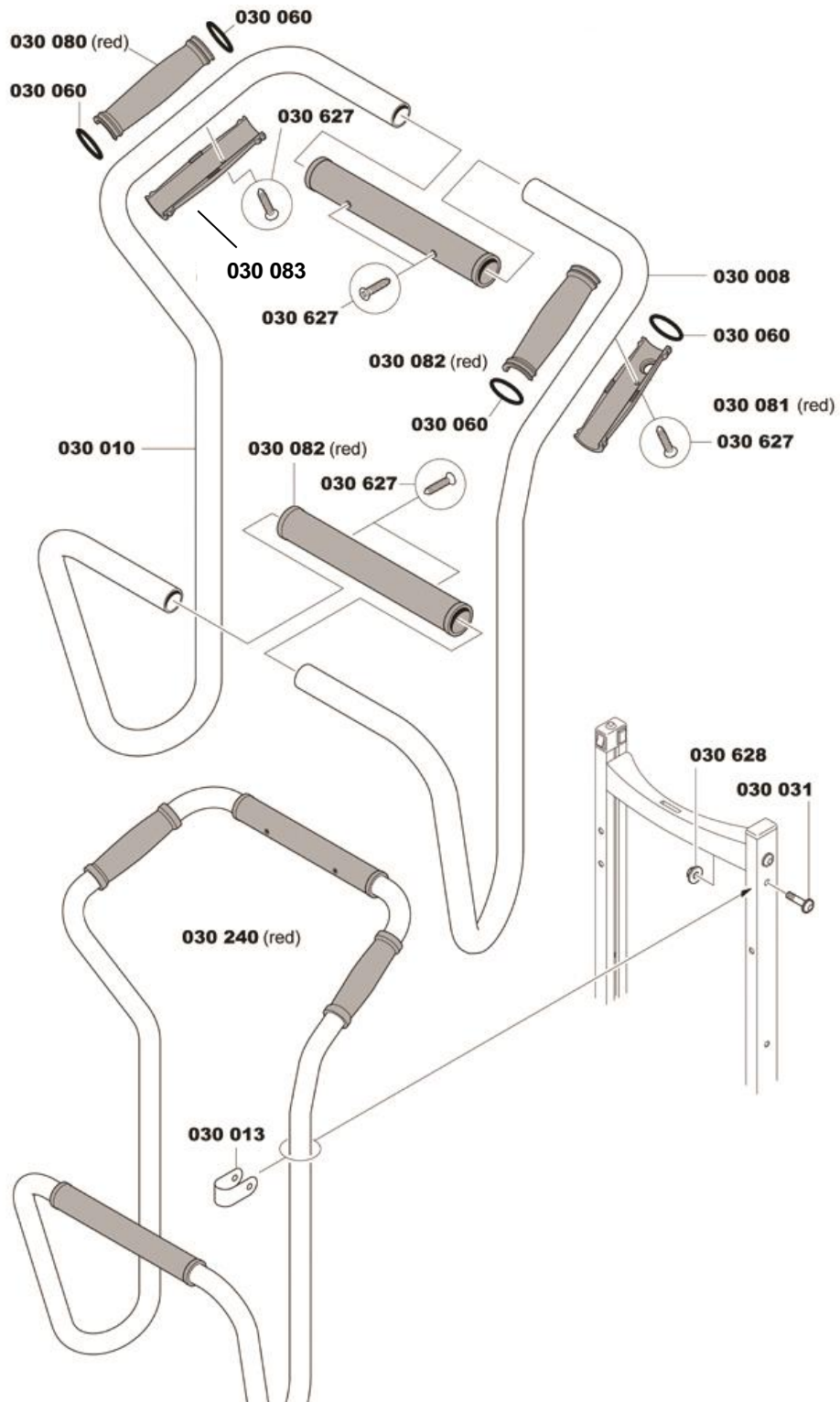

25.8 Handle- Folding

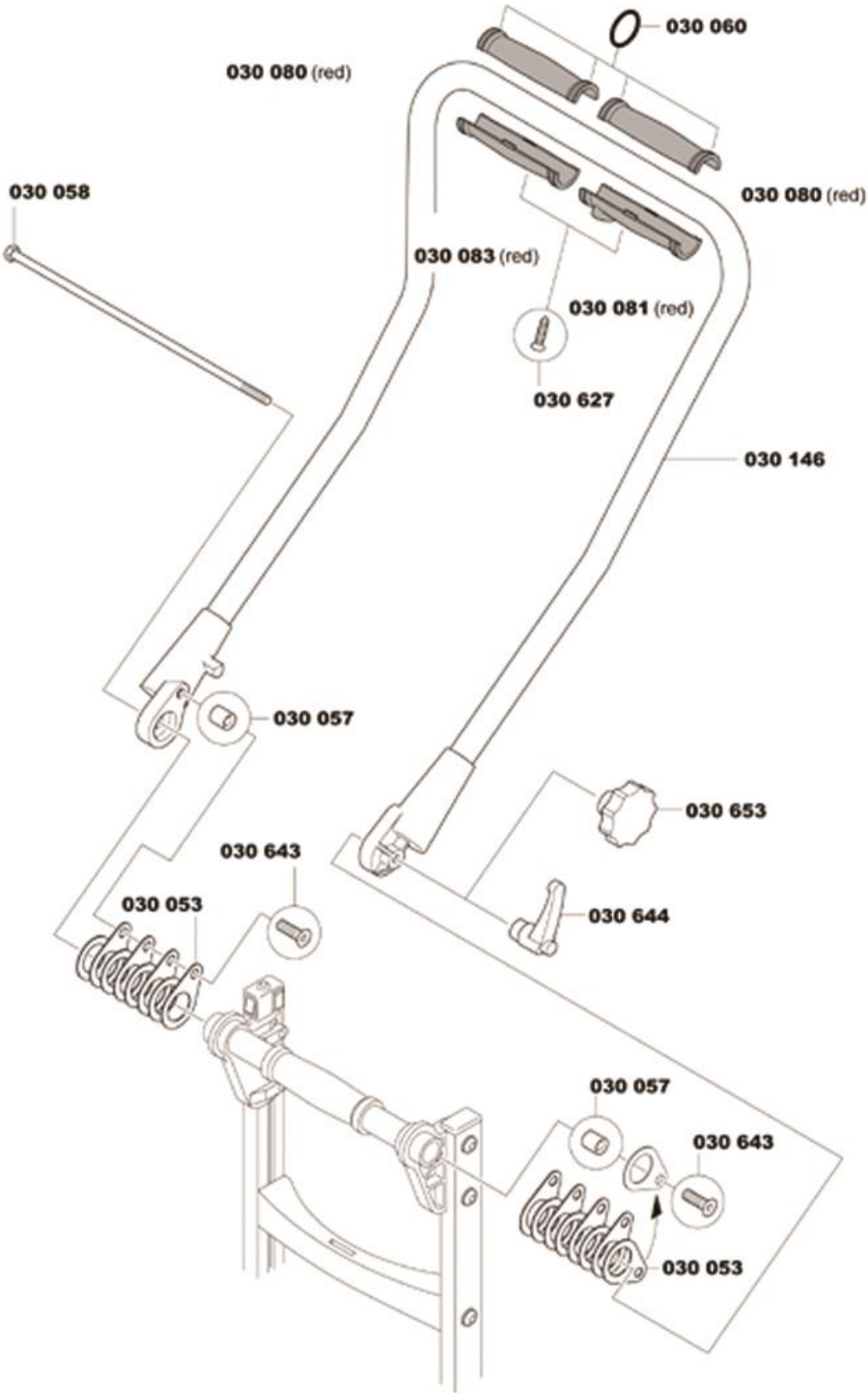

25.9 Handle- Uni

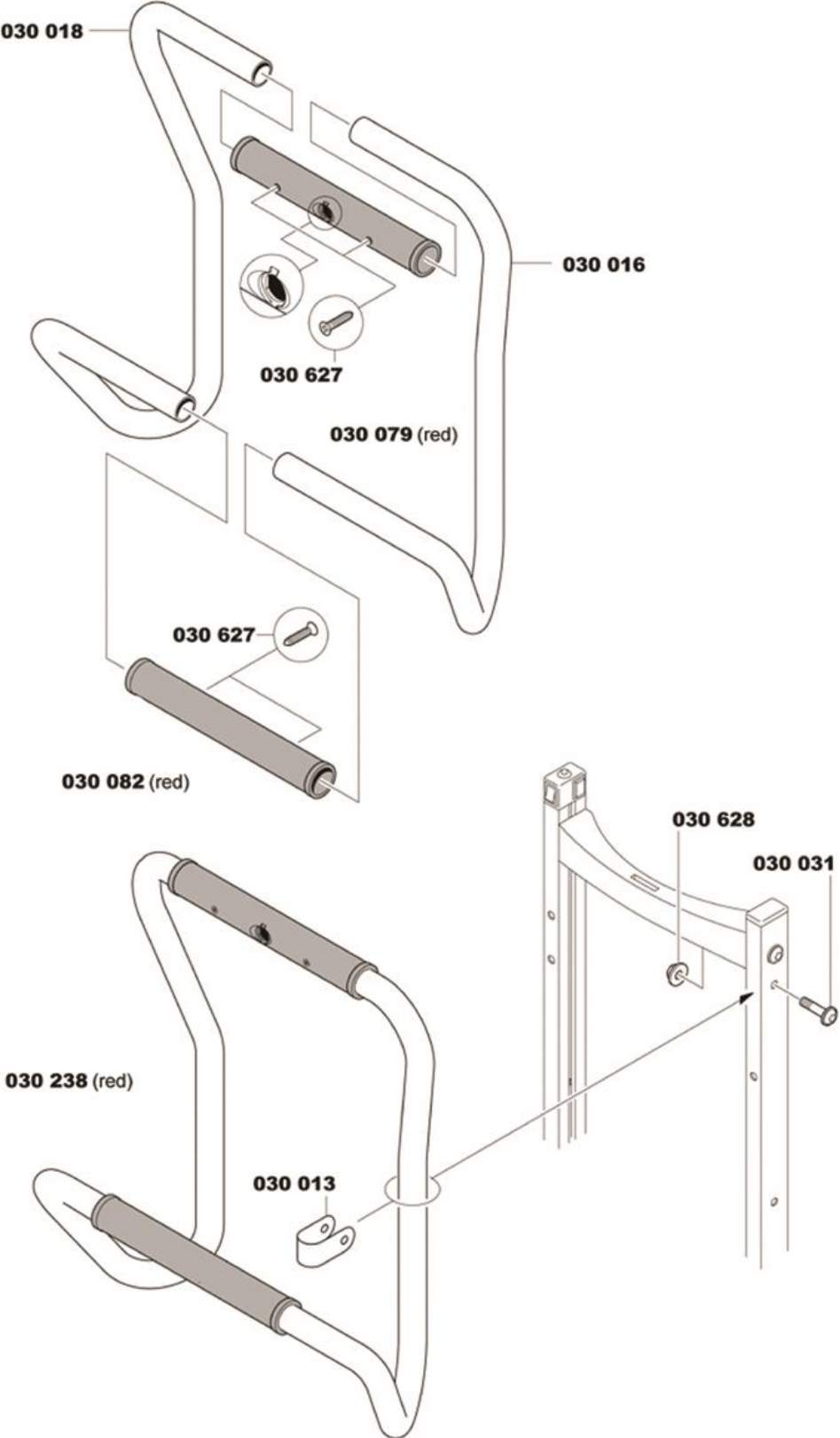

25.11 Hinged or Fixed Nose – Units from Serial No. 201737030

hinged

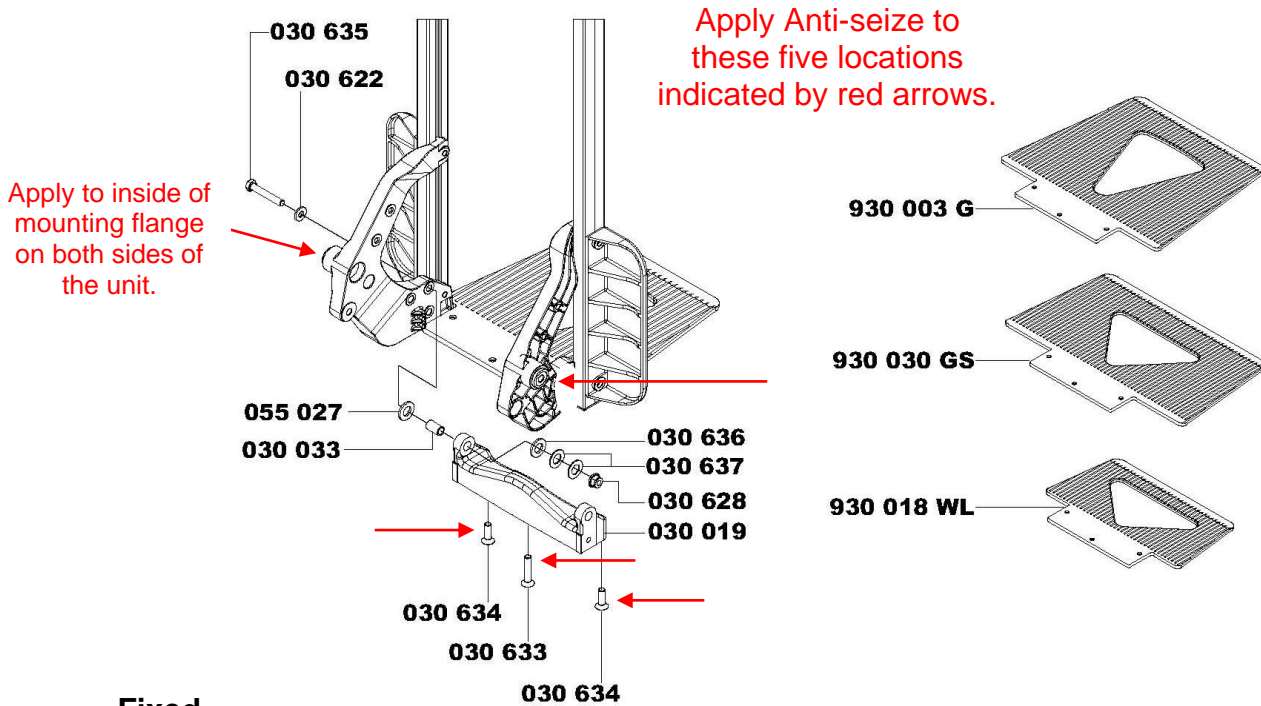

Fixed

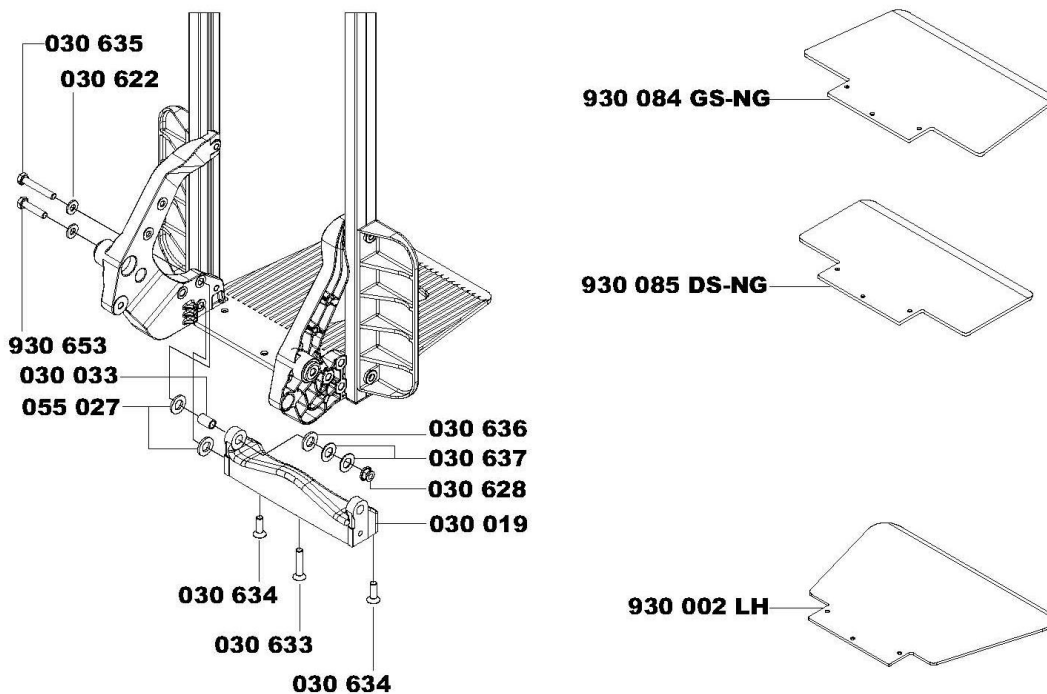

Please note: To change from hinged to fixed nose configuration on Powered Stair Climbing units before Serial No. 201737030, please order 930104K nose kit and 930197K fixed hardware kit.
 Please note – for units with serial number 201633806 through 201735490, AND units with serial number 201737030 and above, the 930197K hinged-to-fixed exchange kit must be ordered if the nose plate is being changed from hinged to fixed. The 930197K kit has the 930653 screw, 030622 washer and 055027 washer used to hold the nose bracket in fixed position.

25.12 Lifting Unit – units built prior to September 2012

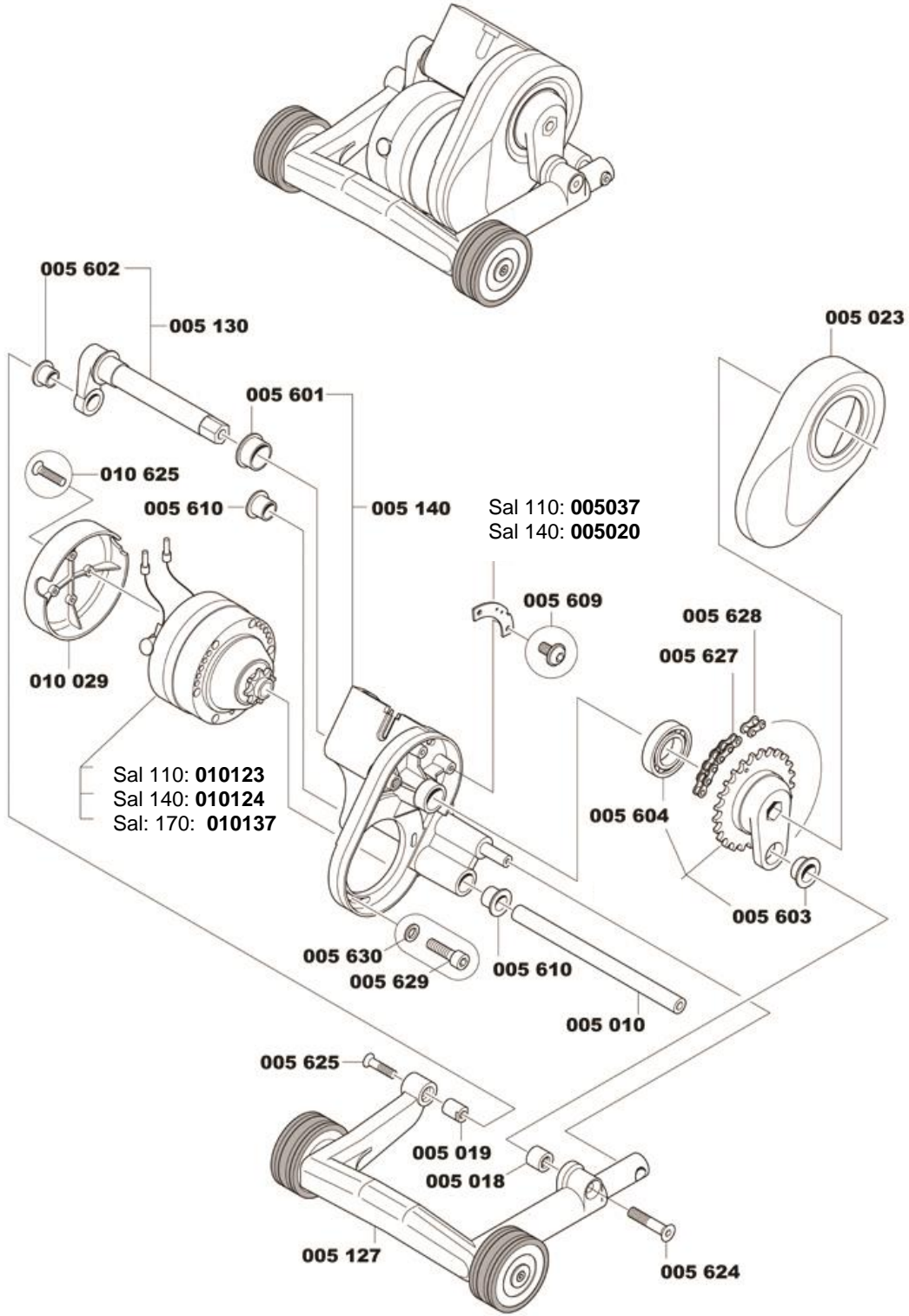

25.12 Lifting Unit – units built after September 2012

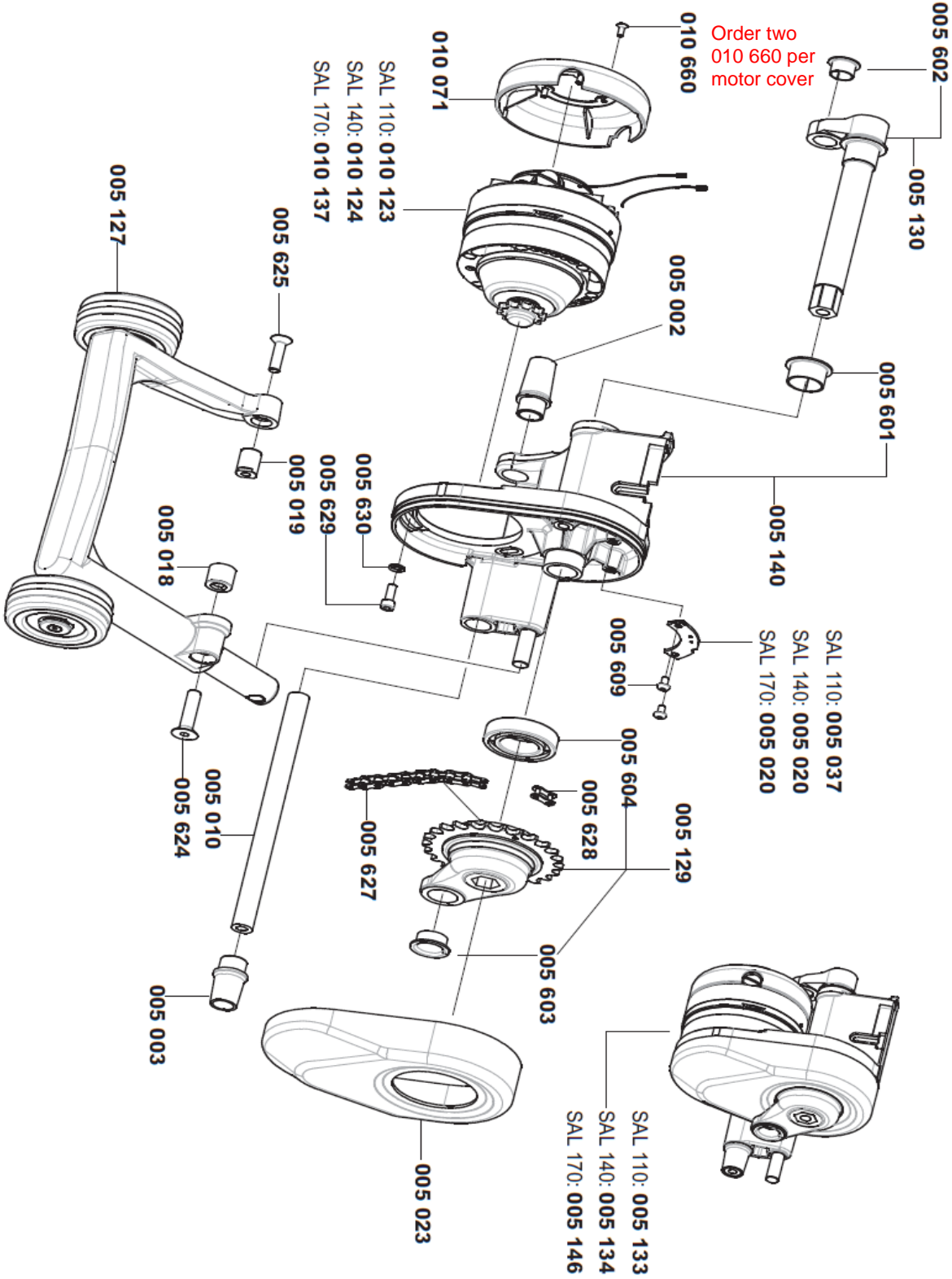

25.13 Lifting Unit Assembly

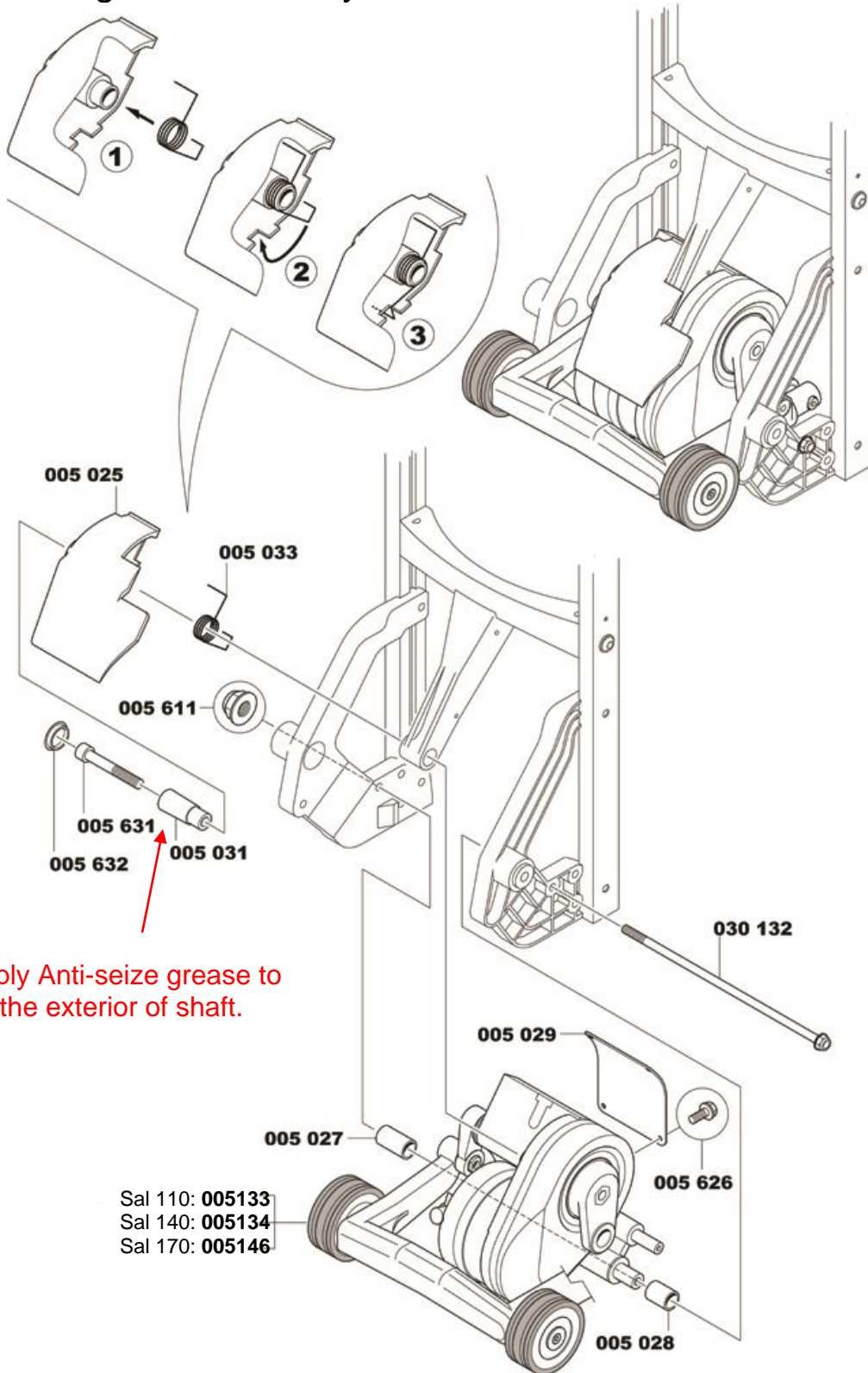

25.14 Swing Arm

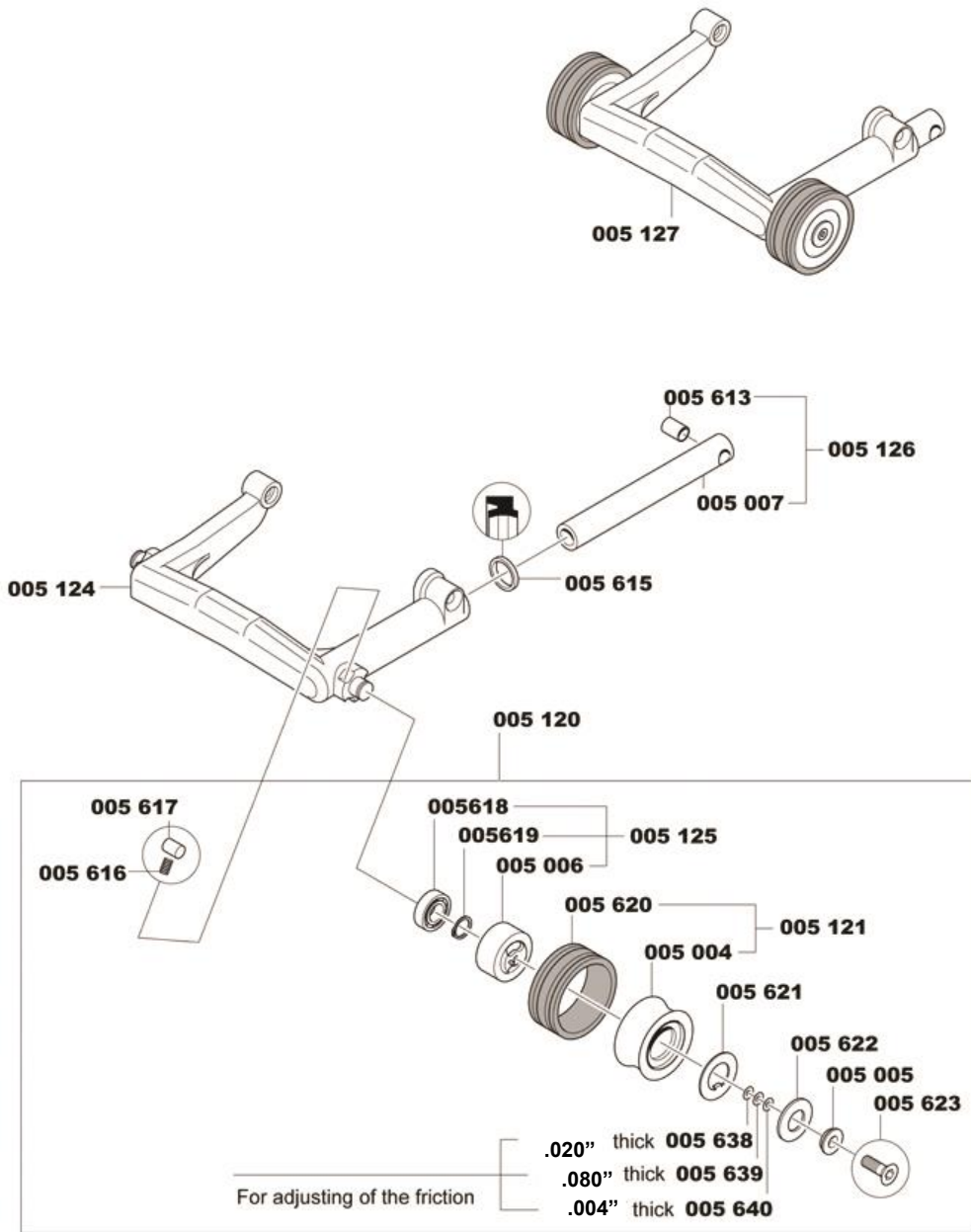

Note: To replace oil in part number 005124, use 1.75 oz. of SAE 90W Gear Lube.

25.15 Wheel

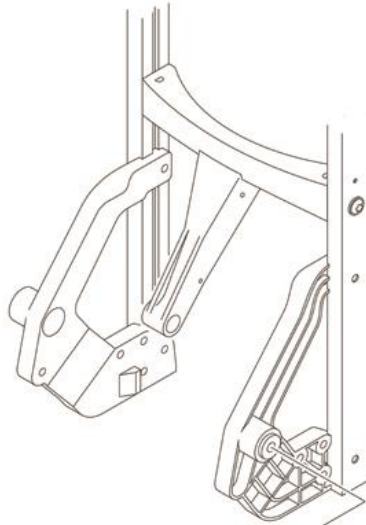

030 245 black / red hub

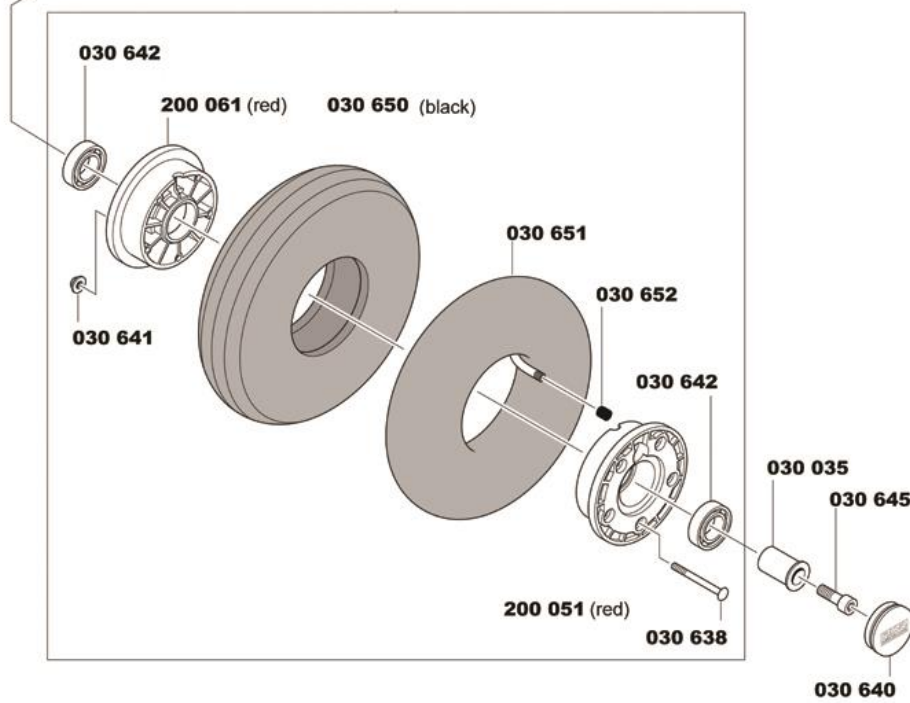

LIFTKAR® is a registered trademark of SANO Transportgeräte GmbH.
Copyright 2005-2021 Magline, Inc. REV 02/21

B8145