

FRAME: TYPE 316 STAINLESS STEEL
 FINISH: POLYESTER POWDER COAT: BLACK WITH ACCENT COLOR
 FLYWHEEL: 316 STAINLESS STEEL
 CRANK: STAINLESS STEEL ROD WITH STAINLESS STEEL BEARINGS
 SEAT: SEAT CAN BE ADJUSTED TO 9 DIFFERENT SETTINGS VERTICALLY AND 4 HORIZONTALLY
 HANDLEBARS: HANDLEBARS CAN BE ADJUSTED TO 7 DIFFERENT SETTINGS VERTICALLY

POOL DEPTH: 3.5 TO 5 FEET(1 TO 1.5 METERS) FOR OPTIMAL USE

BIKE WEIGHT: 38LBS (17KG)
 WARRANTY: 3 YEARS FOR FRAME
 (NOT INCLUDING POWDER COAT)
 1 YEAR FOR PARTS & TRANSMISSION

PROWAVE - COLOR OPTIONS		
CATALOG NO.	PART NO.	COLOR
F-PWRWV-G	INV01923	NEON GREEN
F-PWRWV-Y	INV01922	NEON YELLOW
F-PWRWV-P	INV01921	SASSY PINK
F-PWRWV-C	INV01534	CHOOSE COLOR

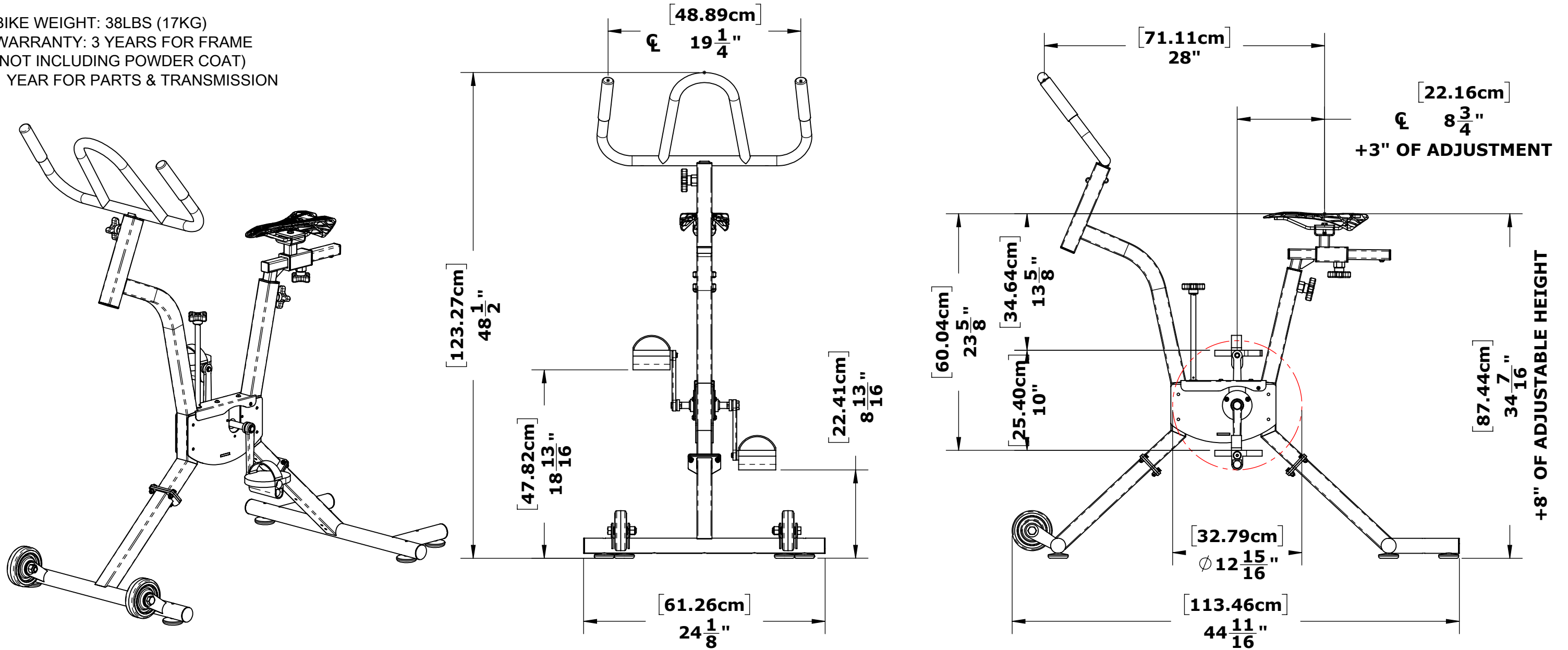

TOLERANCES

DIMENSIONS ARE IN INCHES
 UNLESS OTHERWISE SHOWN
 FRACTIONAL: ±1/16
 ANGULAR: ±1°
 TWO PLACE DECIMAL: ±.01
 THREE PLACE DECIMAL: .. ±.005

PROWAVE
CATALOG NO. F-PWRWV
PART NO. SEE CHART

MATERIAL: STAINLESS STEEL
FINISH: POWDER COAT - PER ORDER
APPROX. WEIGHT: 40.88 LBS.



PROPRIETARY AND CONFIDENTIAL INFORMATION

THIS DRAWING AND ALL INFORMATION CONTAINED HEREIN IS THE SOLE PROPERTY OF AQUA CREEK PRODUCTS LLC. ANY REPRODUCTION IN PART OR AS A WHOLE WITHOUT WRITTEN PERMISSION FROM AQUA CREEK IS PROHIBITED.

REVISIONS			
REV.	DESCRIPTION	DATE	APPROVED
P1	INITIAL RELEASE	10/27/2022	J.MAXWELL