

Tricycle

R120, R130 & R140 Product Manual



Contents

Safety messages	3
Recommended use and item dimensions	4
Important information and check your order	5
Basic components	
Trunk support system	6
Backrest pad	7
Seat and parking brake	7
Handlebar and handbrake	8
Accessories	
Headrest and front guide bar	9
Rear steering bar	10
Abductor and communication tray	11
Stationary stand	12
Operation	13
Maintenance and cleaning	14
Warranty, materials and user modifications	15

WARNING



- Thoroughly read and understand the information in this product manual before attempting to use this product. If the procedures and instructions in this product manual are not followed, serious injury or death could occur.
- A qualified professional must assess the appropriateness and safety of all equipment for each user.
- This product is intended for use by clients of unreliable judgment. Adult supervision is required at all times.
- To prevent falls and injuries:
 - Do not use this product on rough and uneven terrain, around swimming pools, or near stairways.
 - Ensure the appropriate use of straps and supports at all times. Straps and supports are provided for the safety of the user and must be carefully adjusted for comfort and security.
 - Tighten all adjustment knobs before use and immediately after making any adjustments.
 - Fasten all safety belts.
 - Do not use the Rifton Tricycle for clients with strong involuntary movements, poor body balance, or limited head control
 - To prevent injury, client should always wear shoes and a protective helmet.
- To prevent falls, strangulation, head entrapment or other injuries, always use seatbelt when the butterfly harness or headrest are in use.
- Do not use this product for clients outside the height and weight limits specified in this manual.
- To prevent structural failure, which may result in serious injury or death:
 - Inspect this product and accessories regularly for loose or missing screws, metal fatigue, cracks, broken welds, missing attachments, general instability or other signs of excessive wear.
 - Immediately remove this product from use when any condition develops that might make operation unsafe.
 - Do not use Rifton components or products for any purpose other than their intended use.

Recommended use

The Rifton Tricycle is a Class 1 medical device. It can be used for therapeutic reciprocal exercise for maintaining of range of motion and strength, or for recreational purposes for children and adolescents with disabilities. Chain drive from pedals to rear wheel offers the following advantages:

- Pedaling is slightly forward of the seat instead of at front wheel as with many other tricycles. This provides a more efficient, comfortable and natural posture.
- Steering is separate from pedaling, reducing the coordination needed to pedal and steer the tricycle.

User and item dimensions

User dimensions – inches (cm)	R120 small	R130 medium	R140 large
Inside leg length	17–22 (43–56)	22–28 (56–71)	25–35 (64–89)



Key user dimension: inside leg length

The extended leg should reach from seat to pedal comfortably when both feet and torso are strapped into place.

Important: User’s weight must not exceed the maximum working load. Rifton Tricycles are not intended for children with strong reflexes or poorly developed trunk balance and head control. Consult your client’s therapist before ordering.

Item dimensions – inches (cm)	R120 small	R130 medium	R140 large
Overall height (at lowest position)	28½ (72)	31 (79)	36½ (93)
Overall length	46 (117)	52 (132)	65 (165)
Overall width	27½ (70)	27½ (70)	31½ (80)
Wheel diameter	13 (33)	15 (38)	19 (48)
Seat center to extended pedal	17–22 (43–56)	22–28 (56–71)	25–35 (64–89)
Seat to top of trunk support	15½–22 (39–56)	15½–22 (39–56)	15½–22 (39–56)
Distance between trunk laterals	8–14 (20–36)	8–14 (20–36)	8–14 (20–36)
Gear ratio (approximate)	1:1	1:1	1:1
Item weight – lbs (kg)	47 (21)	56 (25)	65 (29)
Max. working load – lbs (kg)	150 (68)	160 (73)	200 (91)

Tray dimensions – Inches (cm)	small	large
Inside dimensions	8½ x 12½ (22 x 32)	11½ x 13½ (29 x 34)
Max. working load – lbs (kg)	10 (5)	15 (7)

IMPORTANT

Please save this product manual for future reference. Additional copies are available at <http://www.rifton.com/customer-service/product-manuals>.

Key for users

Use this key to determine which sections of this product manual apply to you.

 **Technical Users** For professionals who order and set up Rifton products.

 **Home Users** For care-givers who use Rifton products on a regular basis.

 **Maintenance Personnel** For anyone who is responsible for service or re-ordering of Rifton products and parts.

Check your order

Tricycle main frame, handlebar assembly, backrest assembly, front guide bar (if ordered), accessories for the tricycle, and this product manual ship together. Rear steering bar (if ordered) and stationary stand (if ordered) ship in separate cartons.

You may not have ordered all of the available accessories, but use the diagrams that follow to confirm that your order is complete.

If your shipment is incomplete or in any way damaged on arrival, please call Customer Service, 800.571.8198.

Basic item

Trunk support system

⚠ WARNING To prevent falls, strangulation, head entrapment or other injuries:

- Always use seatbelt and lateral supports when butterfly harness is in use.
- **Figure 6a:** Ensure correct adjustment and positioning of the butterfly harness at each use.
- **Figure 6b:** Ensure that the backrest tube extends beyond the front edge of the clamp (E).
- Do not adjust seat while a rider is on the trike.



Figure 6a

Recommended use

The trunk support system aids users who have difficulty remaining upright while sitting. It can be used to correct excessive leaning toward one side.

Attaching:

Figure 6b:

1. Remove knob (A) and clamp channel (B) from trunk support.
2. Place assembly on backrest tubes (C) in the position shown, with the bolt facing the rear.
3. Place clamp channel (B) and knob (A) on the bolt and tighten securely.
4. Repeat procedure for lower ring attachment bar (D).

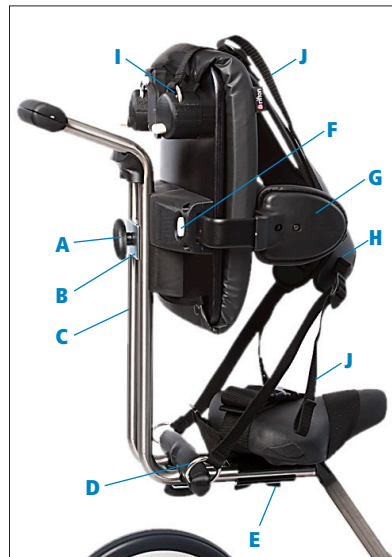

Figure 6b

Transfers and adjustments:

Figure 6b:

1. Push oval release button (F) to remove lateral supports (G).
2. Seat the user on the tricycle, and re-position the lateral supports using

the oval release buttons (F) to make any necessary adjustments to the lateral supports.

3. If desired, clip on butterfly harness (H) using the ring attachment points (D and I) and adjust strap lengths with strap adjusters (J).

Backrest pad

Attaching:

Figure 7a:

1. Remove knob and clamp channel (A) below seat.
2. Slide backrest tubes out.
3. Turn backrest upright and attach with clamp channel and knob (A) below seat.
4. Attach additional backrest pad (B) if needed.



Figure 7a

Adjusting:

Figure 7a: Backrest pad adjusts vertically 12" (30.5 cm) above seat with knob (C), and 3½" (9 cm) horizontally with knob (A).

Seat

Adjusting:

Figure 7b: To adjust seat height, loosen knob (D) move seat to desired position, then partially tighten knob (D). Move the seat up and down slightly to engage the pin in the nearest seat post hole. Tighten knob (D) securely.



Figure 7b

Parking brake

Figure 7c: The parking brake (E) stabilizes the tricycle while the rider is getting on or off. It is for use on flat surfaces only. The brake can be operated by hand or foot.



Figure 7c

Handlebar and handbrake

Hand brake is not available on the small tricycle.

Recommended use:

Figures 8a and 8b: A straight handlebar or loop handlebar can be used with your Rifton tricycle. Hand brake (C) allows the user to slow and stop the tricycle.

Adjusting the straight handlebar:

Figure 8a: The handlebar height adjusts $3\frac{5}{8}$ " (9.2 cm) with knob (A).

Adjusting the loop handlebar:

Figure 8b: Rotate the handlebar toward or away from the rider by loosening the two oval knobs (B). Secure it in required position by tightening both knobs.

Handlebar adjusts vertically $3\frac{5}{8}$ " (9.2 cm) with knob (A).

Operating the hand brake:

The hand brake (C) allows the user to slow and stop the tricycle.

Figure 8b: For the loop handlebar ONLY: the hand brake (C) can be positioned anywhere on the loop handlebar using the hook and loop strap (D) provided.



Figure 8a (straight handlebar)

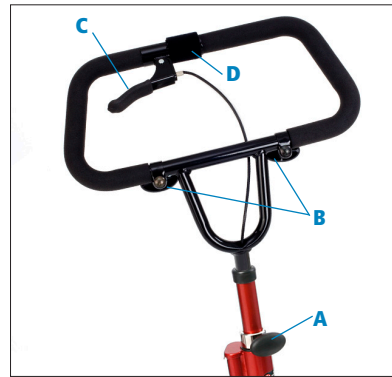

Figure 8b (loop handlebar)

Accessories

Headrest

Figure 9a: Three headrests are available for use with the trunk support system only: flat, contoured and winged.



Figure 9a

Attaching:

Figure 9b: Press white oval button (A) and insert metal headrest bar into slot. Release button to engage headrest and click into place.



Figure 9b

Adjusting:

Figure 9b: Press white oval button (A) and raise or lower headrest. Release button to engage and click into place.

To adjust depth and angle of headrest, loosen both black knobs (B). Move headrest to desired position and tighten both knobs securely.

Front guide bar

Recommended use:

Figure 9c: The front guide bar allows the caregiver to guide and move the tricycle from the front.

Attaching:

Figure 9c: If handlebar is in its lowest position, loosen knob (C) and raise it several inches. This will make the steering bar attachment possible.

1. Loosen knob (A) as far as it goes to open clamp.
2. Attach front guide bar to handlebar as shown.
3. Tighten knob (A).



Figure 9c

Rear steering bar

CAUTION To prevent pinching or crushing, ensure adequate clearance between the handlebar and push rod (C) during left turns. Do not use a very low handlebar position with a high support bar (A) position (see Figure 10a).

Recommended use:

Figure 10b: The rear steering bar enables the caregiver to guide the tricycle from behind.

Before attaching, check the size numbers on the short tube of the rear steering bar to ensure that the rear steering bar is the correct size for the tricycle (R120, R130, or R140).

Attaching:

Figure 10b: If handlebar is in its lowest position, loosen knob (G) and raise it several inches. This will make the steering bar attachment possible.

1. **Figure 10c:** Attach the support bar (A) to the backrest tubes. The clamp channel and oval adjustment knob (B) should face the rear.
2. **Figure 10c:** Snap the push rod (C) into the guide loop (D).
3. **Figure 10b:** Use the clamp knob (E) to open the clamp (F), and then place it over the handle bar U-tube and tighten it.

Adjusting:

Figure 10b: To raise or lower the support bar (A) loosen knob (B) place in desired position and tighten knob (B) again.



Figure 10a



Figure 10b



Figure 10c

Abductor

Recommended use:

The abductor is for clients who require knee separation or abduction.

Attaching:

Figure 11a: Place abductor onto tubes with large end of bracket facing down. Bracket fits snugly onto slanted frame tubes.



Figure 11a

Communication tray

CAUTION To prevent falls and injury, do not use the tray as a body support.

Recommended use:

Figure 11b: The communication tray provides a surface for personal communication devices and other activities. Communication sheets can be placed under the false bottom and electronic devices can be secured to the tray. The tray is easily removed when not in use.



Figure 11b

Attaching and adjusting:

Figure 11b:

Attach tray to the handlebar by loosening the tray knob (E) and placing it over the handlebar in location shown.

1. Tighten knob (E) while holding the tray at desired angle.
2. To attach a communication sheet, push through the holes in bottom of the tray to remove the cover. Insert sheet and replace the cover.

Stationary stand

WARNING To prevent falls and injury, the stand should be centered laterally on the length of the rear axle (see Figure 12a).

Recommended use

Figures 12a – 12c: The stationary stand converts your tricycle into a stationary trainer, for learning the basic motions of pedaling.

Attaching:

1. Place the stand on the floor in the desired location.
2. **Figure 12c:** Lift the tricycle's rear axle into the correct notch on the stand. Use the lowest position for the R120 (small), the middle for the R130 (medium), and the highest for the R140 (large) Rifton Tricycle.



Figure 12a



Figure 12b



Figure 12c

Operation

Adjust seat height so that the distance from seat to foot pedal approximates the key user dimension of the client's inside leg length. The client's extended leg should reach comfortably from seat to pedal when both feet and torso are strapped into place. Approximate the height of the trunk support system so it is appropriate for client's seat to shoulder height (or adjust backrest height if used.) Approximate the optimal position for the handlebar, and make sure the handlebar is out of the way prior to transfer. Make sure the straps on the foot pedals are open and ready for feet placement. Apply the parking brake.

Assist client to transfer to a seated position on the tricycle seat, making use of the low transfer step as needed. Secure the seatbelt immediately when client is seated.

Finalize positioning adjustments for trunk support system and handlebar. Adjust and add further accessories as needed: ie, the support laterals and butterfly harness of the trunk support system (or backrest pad strap if used), the headrest, the abductor, and sandal straps.

Maintenance 🧰

This product is designed and tested for an expected life of 5 years when used and maintained in accordance with this manual. At all times, users must ensure that the product remains in a safe and useable condition, including regular maintenance and inspections as specified in this manual.

To prevent structural failure, which may result in serious injury or death:

- Inspect this product and accessories regularly for loose or missing screws, metal fatigue, cracks, broken welds, missing attachments, general instability or other signs of excessive wear.
- Immediately remove this product from use when any condition develops that might make operation unsafe.
- Do not use Rifton components or products for any purpose other than their intended use.
- Replace or repair components or products that are damaged or appear to be unstable.
- Use only Rifton authorized replacement parts. Order information for replacement parts is provided on the back of this product manual.

Chain is oiled in the factory. If maintenance to chain is required, remove pan by pulling upward on the back of the pan, then remove screw from the side of the chain guard. Retain the screw. Remove chain guard by pulling upward to release from axle. After servicing the chain, the chain guard and screw must be replaced. Snap pan back into place.

Chain tension is factory set. Should it need tightening, do the following:

1. Slightly loosen the two cap screws (A) on top of crank case using a hex head wrench.
2. Use the same size wrench to tighten the cap screw (B) at the front of the plate until slack is removed from chain. Do NOT overtighten.
3. Retighten the two cap screws on top of crank case.

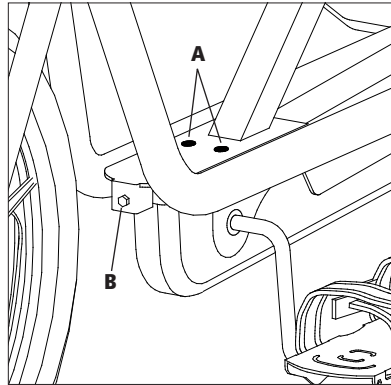

Cleaning 🧑🏠 🧰

As needed, clean Trike with disinfectant wipes or a solution of up to 10% bleach. Do not use excessive amounts of water.

The straps with hook and loop closures may be laundered. Engage the closures before washing. Do not iron.

Warranty Statement

If a Rifton product breaks or fails in service during the first year, we will replace it free of charge.

Materials

- Steel hardware items (nuts, bolts, screws, etc) are typically zinc or nickel plated, or stainless steel.
- Upholstery items (pads, support blocks, padded prompts, etc) are typically polyurethane foam with a fire-retardant cover made from expanded vinyl.
- Frames are typically steel or aluminum tubing, welded together, and coated with a baked-on paint finish. Some frame components may also be stainless steel.
- Tires are tubeless, filled with polyurethane foam, and do not require inflation.
- Straps are typically made of polypropylene or nylon webbing.
- Plastic components are typically injection molded from a variety of industrial resins.

All materials are latex, lead and phthalates free.

User modifications

 WARNING To prevent serious injury or death, do not modify or alter Rifton products or components, or use Rifton products or components in conjunction with products from other manufacturers. Rifton does not accept responsibility for any modifications or alterations made to our components or products after they leave our premises. Customers modifying or altering our components or products, or using them in conjunction with products from other manufacturers, do so at their own risk.

To order replacement parts

1. **Locate the ID number** of the product on the small white label.
2. Have this number available when you call **800.571.8198** for your customer service representative.

Use only replacement parts supplied by Rifton Equipment.

We are glad to supply replacement parts. Although Rifton makes every effort to supply correct parts and instructions for repairing or refurbishing your equipment, you are responsible to make sure that the repairs or modifications are correctly and safely completed.