

REV.	DESCRIPTION	DATE	APPROVED
0	Initial Release	12/17/2008	JXxxx
1	Released for Production	12/17/2009	JXxxx

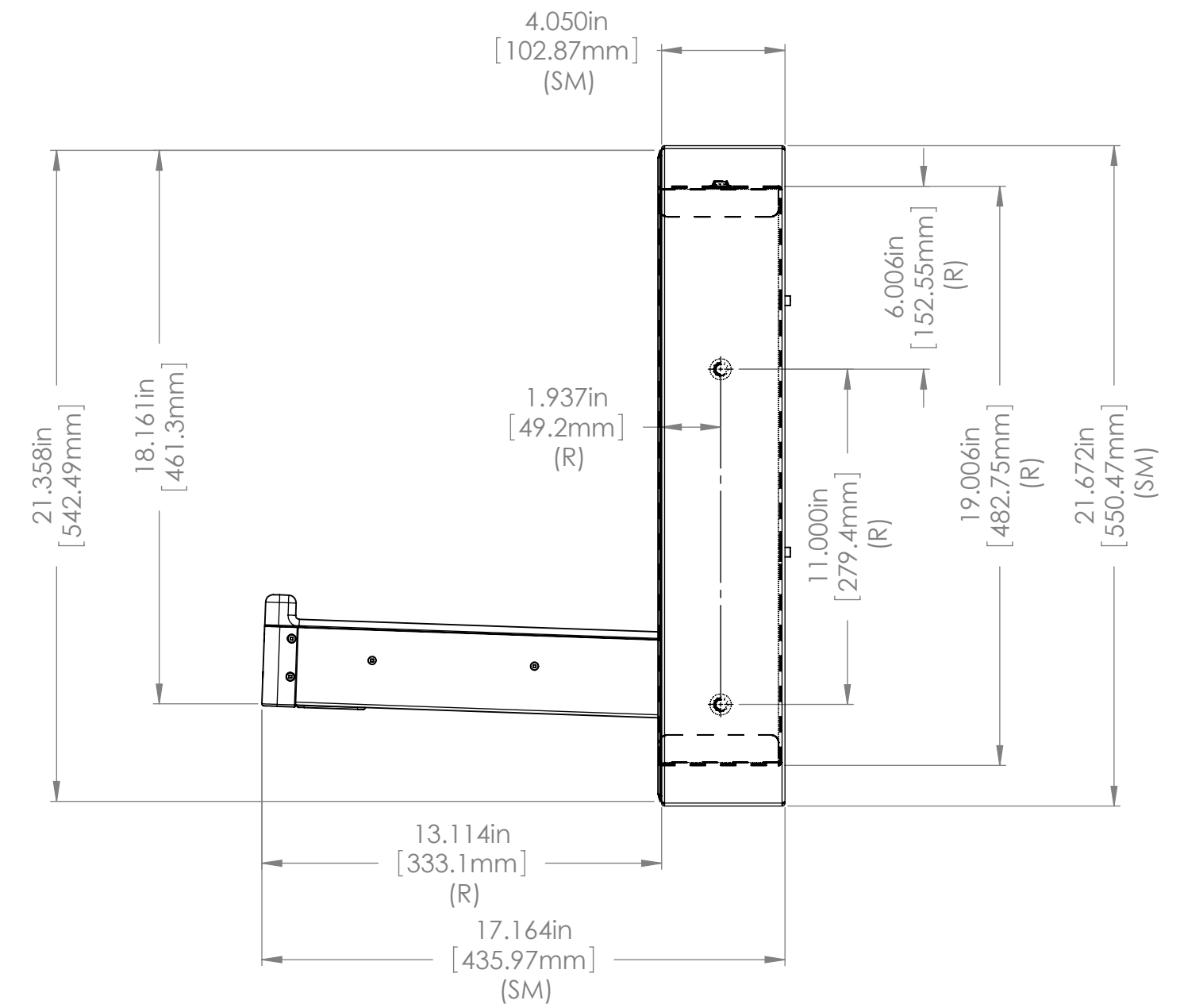
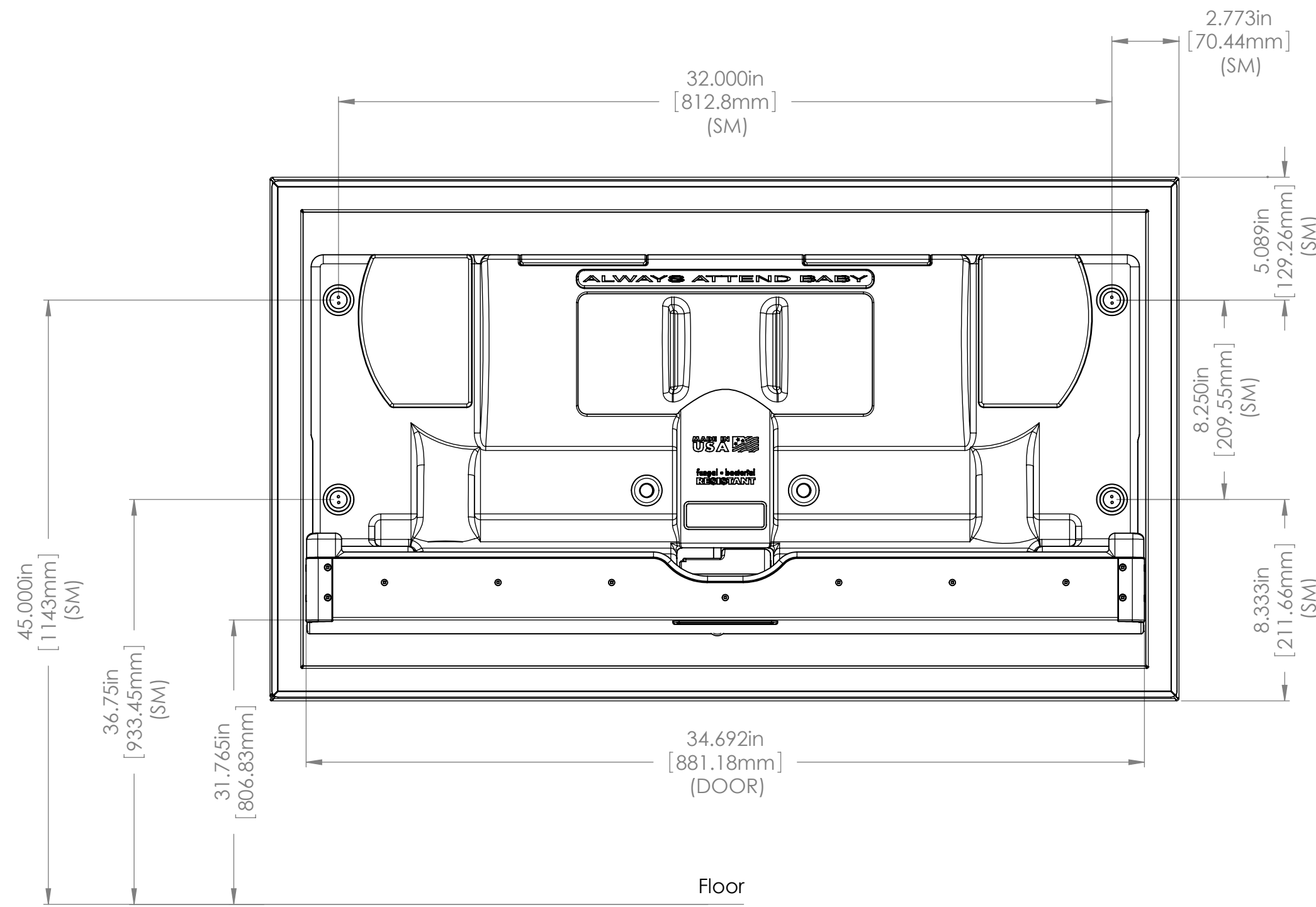
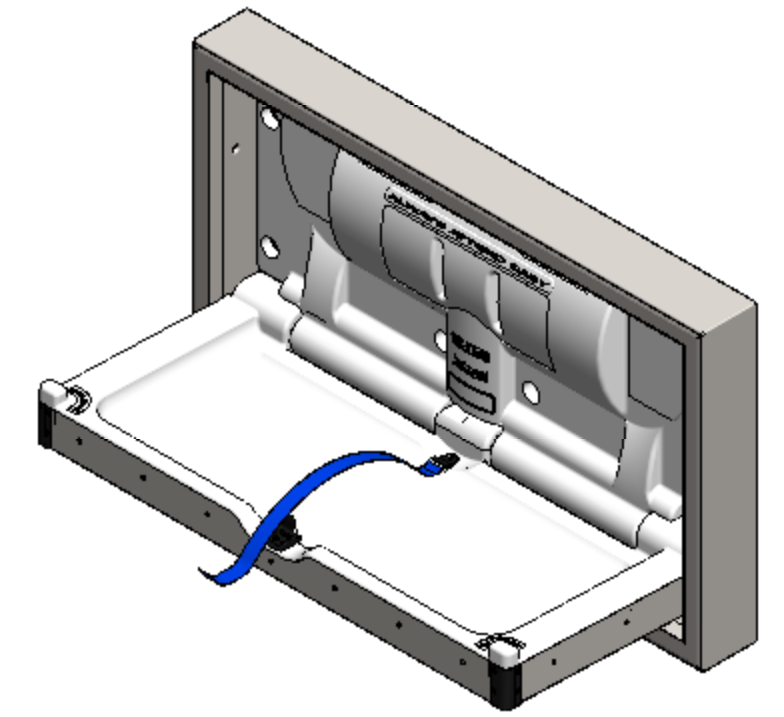
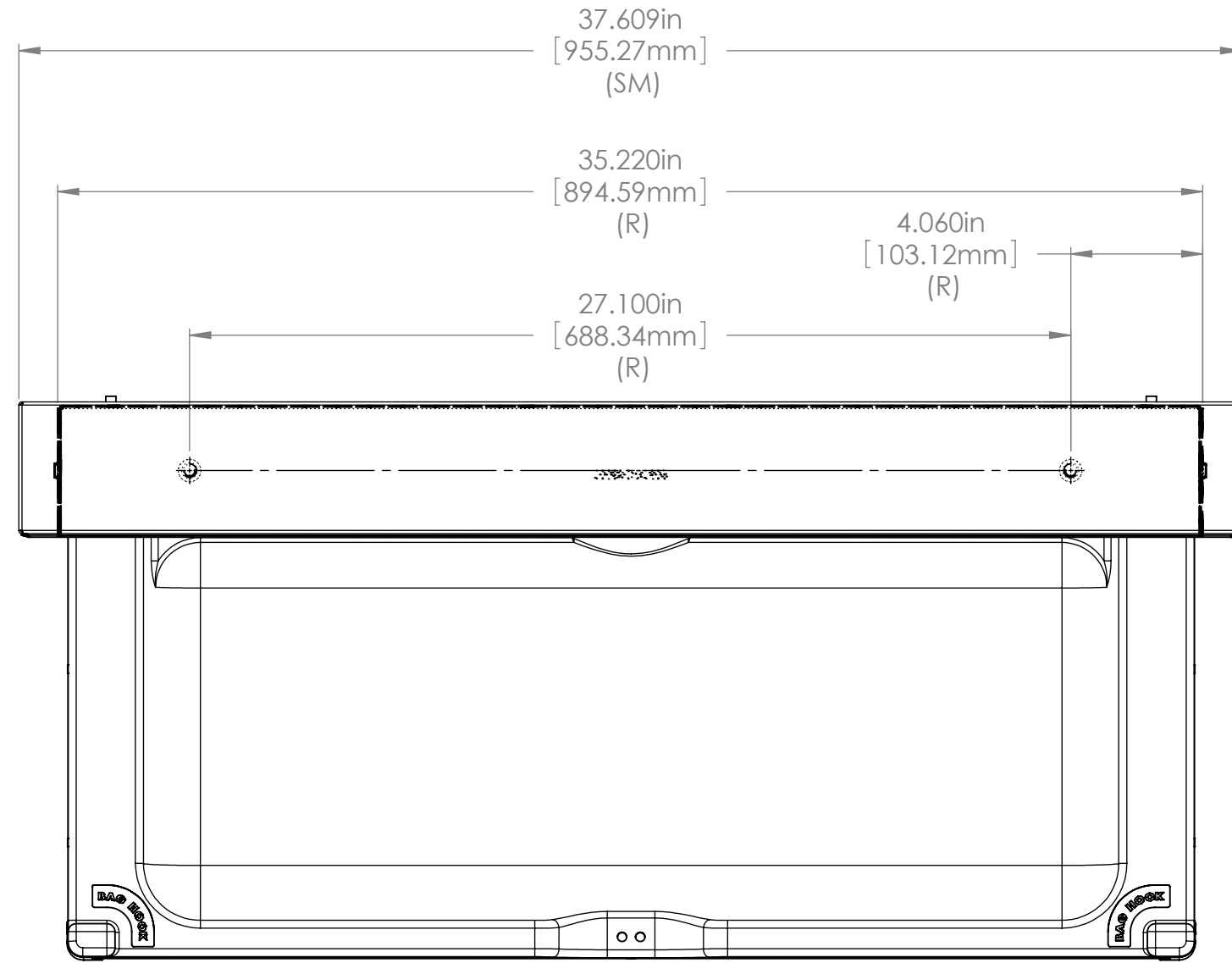

Notes:

SM - Surface Mount
R - Recessed Mount

DIMENSIONAL TOLERANCES: (UNLESS OTHERWISE SPECIFIED) FRACTIONAL: $\pm \frac{1}{32}$ " MACHINED ANGLES: $\pm 0.5^\circ$ BEND ANGLES: $\pm 1.0^\circ$ 0.XX: ± 0.040 in [1mm] 0.XXX: ± 0.0150 in [0.38mm]			
MATERIAL: N/A		DESCRIPTION: Architectural Layout for 100SSC	
FINISH: N/A		PART NO: Arch - 100 SSC	SCALE: NTS
DRAWN BY: JXxxx		DATE: 12/17/2008	REV: 1
		SIZE: C	SHEET: 1 of 1
PROPRIETARY AND CONFIDENTIAL THE INFORMATION CONTAINED IN THIS DRAWING IS THE EXCLUSIVE PROPERTY OF FOUNDATIONS WORLDWIDE, INC. ANY REPRODUCTION OR USE OF THIS DRAWING, IN PART OR IN WHOLE WITHOUT THE EXPRESSED PERMISSION OF FOUNDATIONS WORLDWIDE, INC IS PROHIBITED.			