

PORTABLE PRO POOL 2 LIFT

US PATENT NO'S: [7,249,386 B2] |D507,769 S]

MEASUREMENT TAKEN WITH THE LIFT AT FULL LOAD

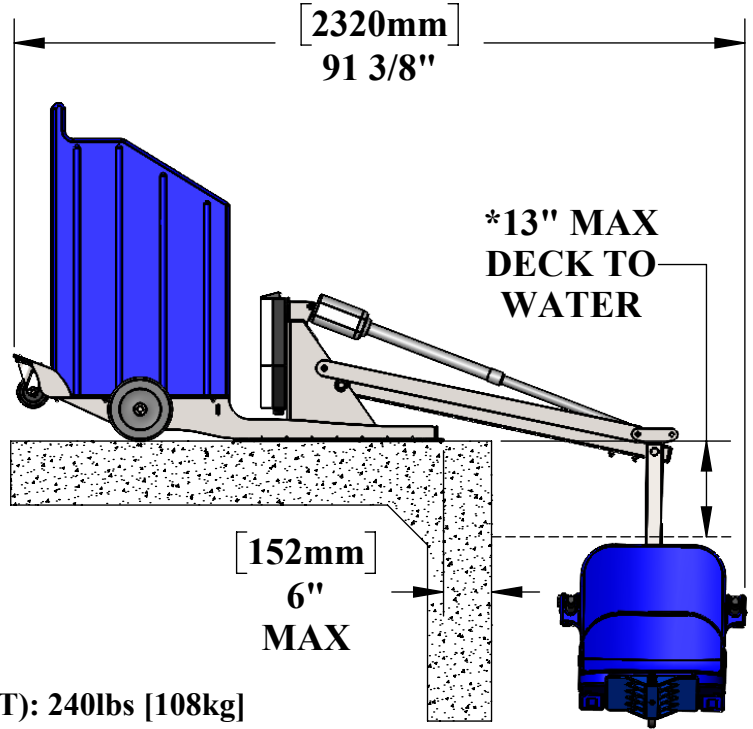
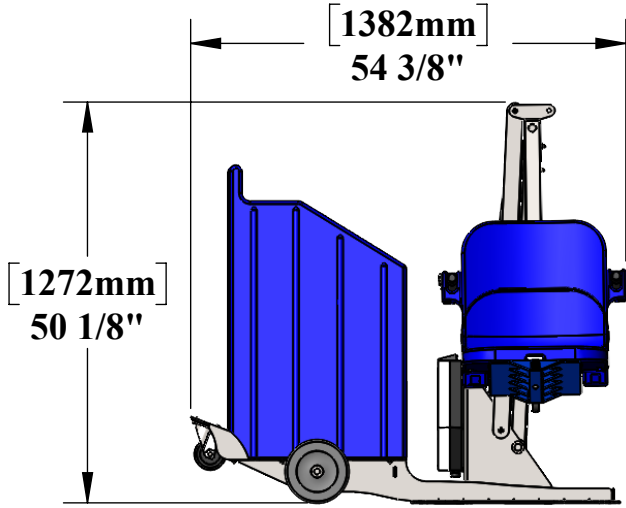

PRODUCT WEIGHT (NO COUNTERWEIGHT): 240lbs [108kg]

PRODUCT WEIGHT (WITH COUNTERWEIGHT): 840lbs [381kg]

MAX WEIGHT CAPACITY: 350lbs [160kg]

MAX SETBACK: 4"

MAX WATER DRAFT: *13"

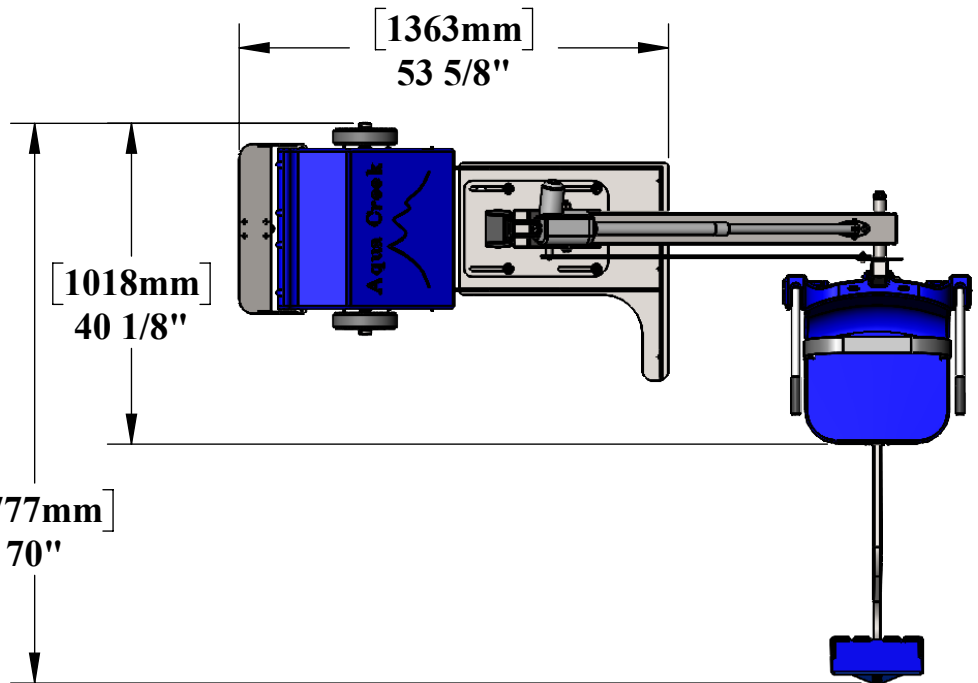

NOTE:
*SPECIFICATIONS ARE SUBJECT TO CHANGE WITHOUT NOTICE

PRODUCT: PORTABLE PRO POOL 2	
PART #: F-PPP2	
SCALE: 1:24	DATE: 7/23/2020
DRAWN BY: KR	REVISION: 01