

T/PUMP[®]

TP600 & 700 Series Localized Temperature
Therapy System



Service Manual









CONTENTS

BEFORE YOU BEGIN . . .	2
SAFETY PRECAUTIONS	3
INTRODUCTION	4
PUMP FEATURES	6
KEYPAD FEATURES TP600 SERIES	7
KEYPAD FEATURES TP700 SERIES	8
KEYPAD FEATURES TP702	9
SPECIFICATIONS	10
CLIK-TITE® CONNECTORS	11
COLDER®-STYLE CONNECTORS	12
START-UP PROCEDURE	13
SHUTDOWN PROCEDURE	13
STORAGE/CLEANING	14
WATER TEMPERATURE CONTROL	16
THEORY OF OPERATION	17
FUNCTIONAL CHECK	18
DISASSEMBLY/REASSEMBLY	24
TROUBLE SHOOTING	26
REPLACEMENT PARTS LIST	32
WARRANTIES	33
Figure 1.a & 1b	4
Figure 2	6
Figure 3	7
Figure 4	8
Figure 5	9
Figure 6	11
Figure 7	12
Figure 8	17
Figure 9.a & 9b	18
Figure 10	21
Figure 11	29
Figure 12	30
Figure 13	31

BEFORE YOU BEGIN . . .

Read and understand this T/PUMP SERVICE MANUAL and all SAFETY PRECAUTIONS prior to servicing the T/Pump.

SYMBOLS USED WITHIN THIS MANUAL AND ON THE PRODUCT

	Warm Water Fill Line
	Cold Water Fill Line
	Attention, consult Operator's Manual.
	Water Levels
	Water Flow
	Dangerous Voltage
	Type BF Applied Part
	Do not penetrate with sharp object.

T/PUMP, T/PAD, Mul•T•Pad, Klik-Tite, and Gaymar are registered trademarks of Gaymar Industries, Inc. U. S. PATENT 4,068,870

© 2008. Gaymar Industries, Inc. All rights reserved.

SAFETY
PRECAUTIONS

⚠ DANGER

- Risk of explosion. Do not use in the presence of flammable anesthetics.
- Risk of electric shock. Disconnect power before servicing the T/Pump.

⚠ WARNING

- This device pumps temperature controlled water through a pad. Set the pad temperature only as directed by and under the guidance of the prescriber.
- Check the skin integrity of the body surface to which therapy is applied. Evaluate patient response to temperature application.
- Check patient's skin for adverse reactions every 30 minutes or as directed by the prescriber.
- Failure to adhere to these warnings could result in patient injury.
- The following Groups/Conditions require additional surveillance:

Group/Condition at risk	Potential Injury
Pediatric patients: The portion of an infant's skin surface in contact with a pad, in relationship to their body mass, can potentially affect their body temperature.	Hyperthermia/ Hypothermia
Patients with impaired circulation	Ischemia
Areas of application under pressure	Ischemia

- Only qualified medical service personnel should repair the T/Pump. Improper repair may result in death or serious injury, equipment damage, or malfunction.
- Use T/Pump TP600 & TP700 series controls with Mul•T•Pads. For catalog numbers and descriptions, see page 5.
- Do not place additional heat sources between the patient and pad. Skin damage may result.

⚠ CAUTION

- Federal law restricts this device to sale by or on the order of a physician.
- Do not cover the control unit with blankets, pillows or other insulating materials. Air flow is required to maintain system performance.

INTRODUCTION

Heat therapy is effective in the dilation of blood vessels, thereby increasing the blood flow to the heated area. Heat therapy has a variety of uses, the most common being treatment of aches and pains in joints and muscles.

Cooling therapy assists in vasoconstriction, decreasing blood flow and decreasing the metabolism in the affected area. Cooling therapy is applied in the acute phase of injury minimizing blood loss, inflammation of the tissue, and can be effective in pain management.

The GAYMART/Pump® Localized Temperature Therapy System provides therapy by warming or cooling the enclosed water, and circulating it through the Gaymar Mul•T•Pad. The pad is connected to the Gaymar T/Pump with easy-to-use Klik•Tite® or Colder®-style connectors.

The Mul•T•Pad provides the interface for delivering the temperature therapy. The unique button design allows water to flow and provides trouble-free operation when the pad is folded to form a customized fit. This reduces the number of pads your facility must keep in inventory. The pads are applied to the part of the body requiring therapy, and the circulating water maintains the pad at the setpoint temperature. The setpoint temperature (TP700 series only) can be locked to prevent tampering.

Connecting the Pads

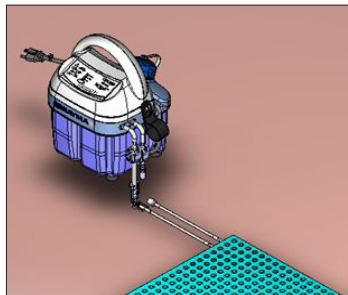

Figure 1a: Localized Temperature Therapy System with Single Pad with the TP650 and TP700 Series.

The Mul•T•Pads can be interconnected using Klik•Tite® connectors to provide therapy to more than one body site at a time.

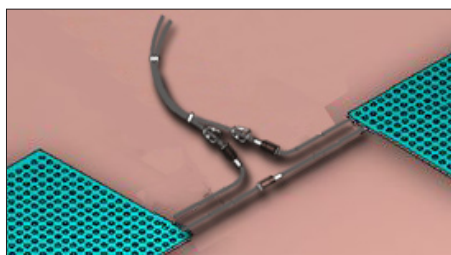

Figure 1b: Localized Temperature Therapy System with Multiple Pads.

Figure 1: Single Pad, Multiple Pad Connections

Catalog Descriptions

Catalog #	Product Name
TP650	Classic Control Unit
TP700/TP702	Professional Control Unit
TP22B *	Mul•T•Pad: 15"w x 22"l (38cm x 56cm) All Polymer. 10 per carton
TP22C *	Mul•T•Pad: 15"w x 22"l (38cm x 56cm) Nonwoven fabric on one side, pliable polymer on the other side. 1 per carton
TP3E*	Mul•T•Pad: 3"w x 23"l (8cm x 58cm) Nonwoven fabric on one side, pliable polymer on the other side. 10 per carton
TP12E	Mul•T•Pad: 13"w x 18"l (33cm x 46cm) Nonwoven fabric on one side, pliable polymer on the other side. 20 per carton
TP22E	Mul•T•Pad: 15"w x 22"l (38cm x 56cm) Nonwoven fabric on one side, pliable polymer on the other side. 20 per carton
TP26E	Mul•T•Pad: 18"w x 26"l (46cm x 66cm) Nonwoven fabric on one side, pliable polymer on the other side. 10 per carton
TP22G	Mul•T•Pad: 15"w x 22"l (38cm x 56cm) Heavy Polymer, Reuseable. 10 per carton
TP650C	Classic Control Unit with Colder®-style connectors
TP700C	Professional Control Unit with Colder®-style connectors
TP612E	Mul•T•Pad: 13"w x 18"l (33cm x 46cm) Nonwoven fabric on each side with Colder®-style connectors. 10 per carton
TP622E	Mul•T•Pad: 15"w x 22"l (38cm x 56cm) Nonwoven fabric on each side with Colder®-style Connectors. 10 per carton
TP626E	Mul•T•Pad: 18"w x 26"l (33cm x 46cm) Nonwoven fabric on each side with Colder®-style Connector. 10 per carton

* Non-CE Products

PUMP FEATURES

Easy to Use Keypad	See KEYPAD FEATURES TP600 series, TP700 series and TP702.
Attached hose	10 ft (305 cm) dual hose. Connectors allow pads to be connected to the pump (Figures 1A and 1B).
Flow indicator	Indicates no flow. Turns off heater if pump is tipped.
Warm/Cool Delivery	Three setpoints on the TP600 series. Four temperature setpoints on the TP700 series.
Therapy Cycles (TP700 series only)	Choose from 20-minute, 30-minute, or Continuous cycles.
On/Standby Button	Indicates power is supplied to the unit.
Over Temp Safety Thermostat	Limit thermostat shuts off pump and heater if the high temperature limit is exceeded.
Self Check	Automatic system check at startup.
Hose/cord Management	Convenient and easy storage areas for hose and cord.
Comfortable Handle Design	Designed for a more comfortable grip when moving the pump.
Dual Micro Processor	Two electronic circuits, one over temperature sensing circuit.
Tethered Easy-Open Cap	Prevents misplacing the cap. Only 1/4 of a turn is needed to remove or secure the cap.
Handle Vents	The vents in the handle allow air flow to keep the motor and heater inside the unit cool.

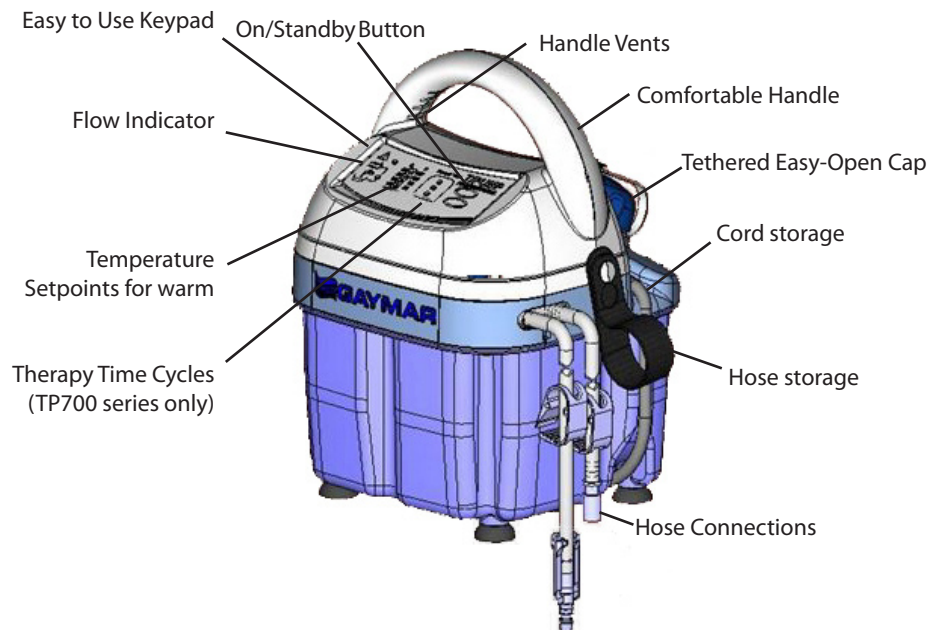

Figure 2: T/Pump Features

KEYPAD FEATURES
 TP600 SERIES

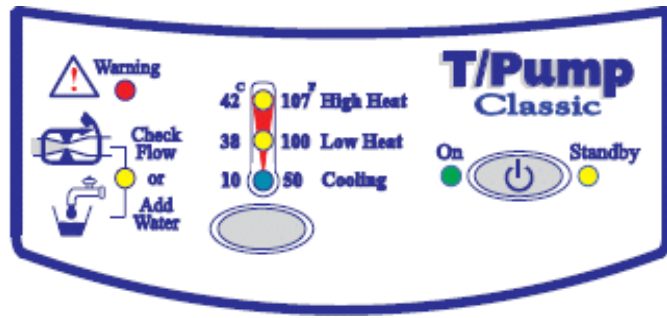



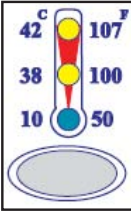



Figure 3: TP600 Series Keypad

Indicator/ Warning Light	 See the Troubleshooting section.
	 Water Flow Check hoses and clamps for kinks or occlusions.
	 Water Level Check water level.
Setpoints	Press the button at the bottom of the setpoint indicator to toggle through the three setpoints. High Heat is 107°F (42°C). Low Heat is 100°F (38°C). Cooling is 50°F (10°C). 
On/Standby Button	Green indicates the unit is on. Yellow indicates power is supplied to the unit but the unit is not on. 

KEYPAD FEATURES
TP700 SERIES

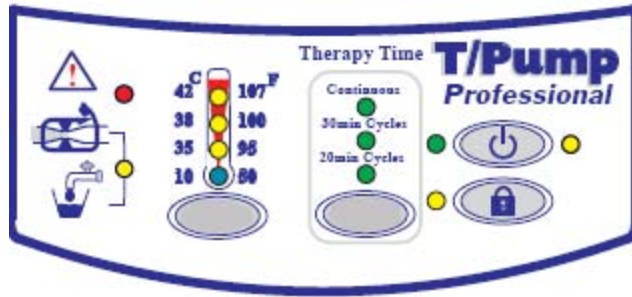



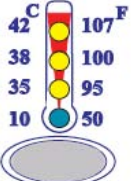

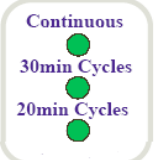



Figure 4: TP700 Series Keypad

Indicator/ Warning Light	 See the Troubleshooting section.
	 Water Flow Check hoses or clamps for kinks or occlusions.
	 Water Level Check water level.
Setpoints	Press the button at the bottom of the setpoint indicator to toggle through the four setpoints. Temperatures are identified in °C and °F. 
Setpoint Lock	Prevents tampering. Press and hold for 2 seconds to lock or unlock the setpoint. 
Therapy Cycles	Continuous cycle, 30-minute cycle or 20-minute cycle. 
On/Standby Button	Green indicates the unit is on. Yellow indicates power is supplied to the unit but the unit is not on. 

KEYPAD FEATURES
TP702

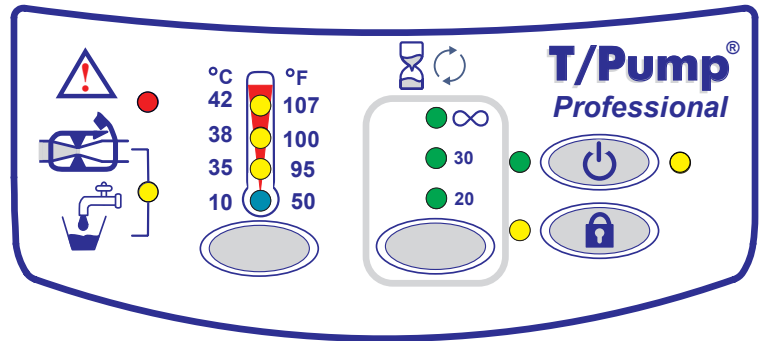



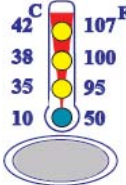

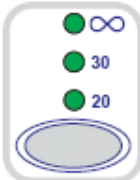



Figure 5: TP702 Keypad

Indicator/ Warning Light	 See the Troubleshooting section.
	 Water Flow Check hoses or clamps for kinks or occlusions.
	 Water Level Check water level.
Setpoints	Press the button at the bottom of the setpoint indicator to toggle through the four setpoints. Temperatures are identified in °C and °F. 
Setpoint Lock	Prevents tampering. Press and hold for 2 seconds to lock or unlock the setpoint. 
Therapy Cycles	 Continuous cycle, 30-minute cycle 20-minute cycle.
	Green indicates the unit is on. Yellow indicates power is supplied to the unit but the unit is not on.

SPECIFICATIONS

	120V Models	230V Models
Electrical Classification	Class I equipment with Type BF applied part suitable for continuous operation. Not classified for protection against ingress of liquid. Not classified for use in the presence of flammable anesthetics.	
Size (approx.)	11.5" x 8" x 8" 29.2cm x 20.3cm x 20.3cm	
Weight	6.5 lbs (2.9 kg) when empty 9 lbs (4.0 kg) with unit filled with water to heating level	
Reservoir capacity	93 oz (2.75 l) maximum	
Flow rate	9 gph (34 lph) minimum with pad attached	
Ambient operating temperature	60°F to 90°F (15.6°C to 32.2°C)	
Environmental conditions for transport and storage	-20°F to 120°F (-28°C to 48°C) At uncontrolled RH	
Temperature setpoints	TP650 Classic 107°F (42°C) High heat 100°F (38°C) - Low heat 50°F (10°C) - Cooling TP700 Professional 107°F (42°C) 100°F (38°C) 95°F (35°C) 50°F (10°C)	TP702 42°C 38°C 35°C 10°C
Average temperature accuracy	±2°F at 107°F (±1°C at 42°C)	
Maximum Contact Surface Temperature	107°F (42°C)	
High Limit Safety Temperature	111°F to 118°F (44°C to 48°C)	
Power cord	International (harmonized) 3-wire cordset	Modular
Current leakage	300 microamperes maximum	500µA Max
Ground resistance	0.5 ohm max	
Electrical requirements Voltage (VAC) Frequency (Hz) Current (amps)	120±10% 60 3.1 amperes	230± 10% 50 Hz 1.6 A
Certifications	MEDICAL ELECTRICAL EQUIPMENT WITH RESPECT TO ELECTRICAL SHOCK, FIRE, AND MECHANICAL HAZARDS ONLY IN ACCORDANCE WITH UL 60601-1, AND CAN/CSA C22.2 NO 601.1, ASTM F 2196-2002  EN 60601-1-2	EN 60601-1-2 IEC 60601-1 EN 60601-1

CLIK-TITE® CONNECTORS

Note: Refer to Figure 1B on page 4 when connecting multiple pads.

The TP600 & 700 Series T/Pump is supplied with Clik-Tite® connectors.

To connect and disconnect Clik-Tite® connectors from hose to pad:

1. Insert male fittings into female fittings with a twisting motion (Figures 6A and 6B).
2. When fittings are fully inserted, snap locking ring into place (Figures 6C and 6D).
3. To disconnect, reverse the procedure.
4. To open or close the hose pinch clamps:
 - Open the clamp by pushing the serrated end (Figure 7B).
 - Close the clamp by pressing the clamp together (Figure 7C).

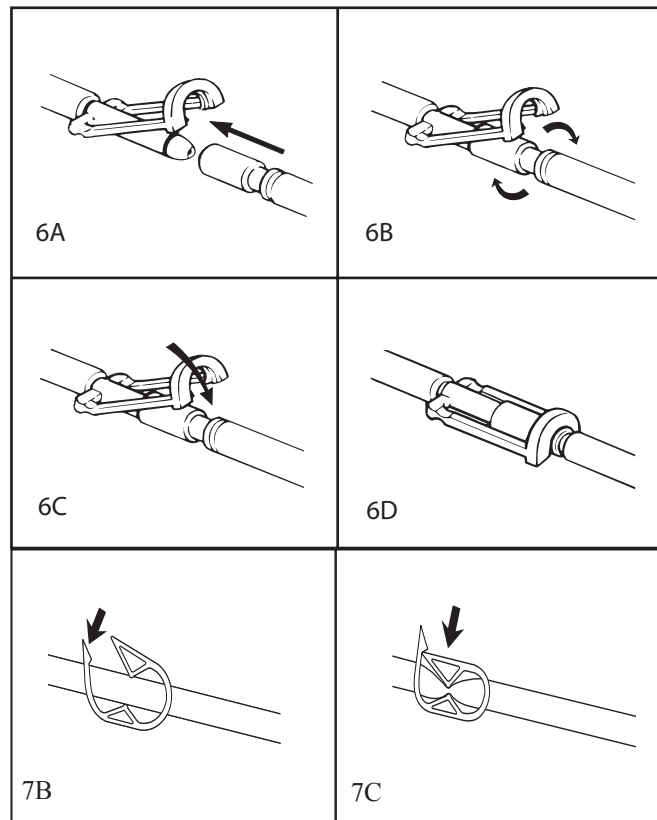

Figure 6: Clik-Tite® Connectors

COLDER®-STYLE
CONNECTORS

To connect and disconnect Colder®-style connectors to a pad:

1. Push the male coupling onto the female coupling. When you hear an audible click, the connectors are joined (Figure 7A).
2. To open or close the hose pinch clamps:
 - Open the clamp by pushing the serrated end (Figure 7B).
 - Close the clamp by pressing the clamp together (Figure 7C)
3. To disconnect, press down on the thumb tab of the female coupling. The couplings will partially disconnect.
4. Pull the male coupling out fully to disconnect (Figure 7D).

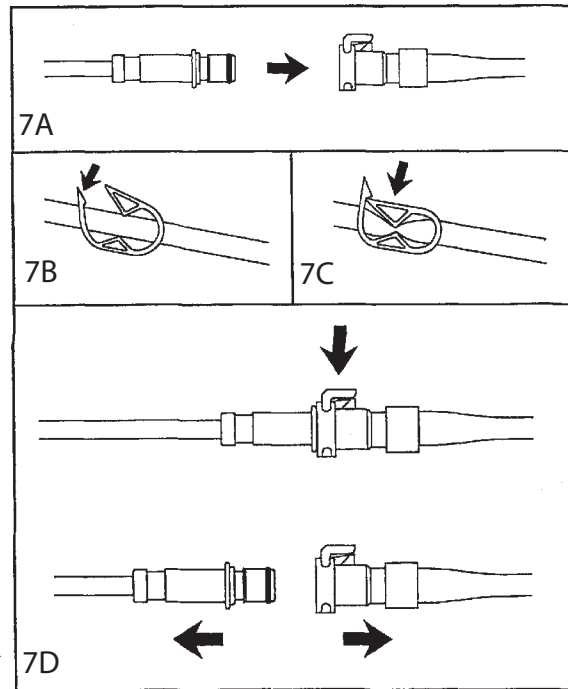

Figure 7: Colder®-Style Connectors

START-UP PROCEDURE

1. Before filling the pump, always attach a pad to the connector hose or close the clamps on the connector hose ends. Make sure that there are no kinks in the hose or pad. Open the hose clamps.
2. Open the fill cap on top of the pump.
3. To fill for cooling:
 - a. Fill with cold water to the Cooling water line.
 - b. Fill with ice to the full capacity of the reservoir.
4. To fill for heating, fill with room temperature water to the Heating water line.
5. Plug the T/Pump into a properly grounded Hospital Grade receptacle.
6. Press the On/Standby button.



The light next to the selected temperature begins to flash.

7. Use the keypad to set the temperature as directed by the prescriber. For the TP700 Series only, after setting the temperature, press and hold the lock Temperature Setpoint button for 2 seconds to lock the setpoint.

Note: If you toggle past the desired setpoint, keep toggling to start at the beginning of the setpoint column.

If warming, the selected water temperature will be reached in approximately 11 minutes and the light next to the selected temperature becomes steady.

8. Check the water level. If it drops below the operating level, add water.
9. Apply the Mul•T•Pad to the patient as prescribed. Follow the Mul•T•Pad instructions.
10. Position the pump at or above the level of the pad.

Note: If the pump is placed below the pad(s), water will drain into the pump when it is shut off. If the pump has been overfilled or if multiple pads are connected, excess water can leak.

SHUTDOWN PROCEDURE

1. Press the On/Standby button so that the Standby light is lit.
2. Unplug the T/Pump.
3. Close all hose clamps.
4. Disconnect pad(s) from pump.
To prevent water spillage, always disconnect pad from pump with connectors raised above the level of the pad and pump.
5. Coil the hose, and attach the Clik-Tite® connectors together on the hose (See Figure 5), where applicable.
6. Secure the hose to the T/Pump using the tube set strap.
7. Wrap the power cord around the unit.

STORAGE / CLEANING

Storage (Short term)
Less than 1 day

1. Close the hose clamps.
2. Disconnect the pad.
3. Connect ends of the connector hoses together, where applicable.
4. Open the hose clamps.
5. Leave water in the reservoir.
6. Coil and fasten the hose using the tube set strap and wrap the power cord around the unit.

Storage (Long term)

1. Drain the pump. (See instructions below.)
2. Coil the hose, rather than folding it, to prevent hose kinks.
3. Fasten the hose using the tube set strap and wrap the power cord around the unit.

Draining

1. Disconnect the T/Pump from AC power.
 2. Clamp the hose clamps.
 3. Disconnect the pad or hoses from one another, keeping hoses at or above the level of the T/Pump.
 4. Open the hose clamps.
 5. Remove the fill cap and invert the T/Pump over a sink.
 6. When all fluid has drained from the hoses and reservoir, replace the fill cap.
 7. Connect the hoses together, where applicable.
-
-

Institutional
(Hospital) Cleaning
Instructions

Note: Clean and change the water monthly or more often depending on use.

Clean the outer surfaces of the T/Pump with one of the following:

- A damp cloth and soapy water.
 - A spray cleaner such as Fantastik
 - A mild abrasive cleanser without bleach.
1. Prepare a germicidal solution according to the manufacturer's instructions. Use AirKem A-33, available from Ecolabs, Inc., 370 Wabasha, St. Paul, MN 35102 (phone: 1 800 247-5362), or from GAYMAR, product catalog MTA33.
 2. Drain the pump.
 3. Connect hose set together.
 4. Fill the reservoir to the Heating water line on the back of the reservoir.
 5. (TP650) Select Low Heat on the keypad.
(TP700 Series) Select the 95°F (35°C) temperature setpoint on the keypad.
 6. Start the T/Pump, and circulate the solution for one hour.
 7. Drain the solution and refill the pump with clean water.

NOTE: In a home environment, perform only step 2 and the refill instructions in step 7.

Pads / Accessories

Only use Mul•T•Pads®. The unique button design allows optimal water flow and provides trouble-free operation when the pad is folded. This reduces the number of different sizes of pads your facility must keep in inventory.

The Mul•T•Pads with Klik-Tite® connectors can be interconnected to provide therapy to more than one body site at a time (Figure 1B, page 4). Refer to Catalog Descriptions on page 5 for a list of various pads and ordering information.

WATER TEMPERATURE CONTROL:

There are three devices that control the operation of the heater in the GAYMART/Pump:

- The temperature is thermistor controlled (fig 8, item 8). This temperature is selectable from the operator's keypad (fig 8, item 10). To prevent unauthorized temperature setting changes, a lockout key is available on the TP700 "Professional" model.
- The limit thermostat (fig 8, item 2) is mounted on the brass manifold block (figure 8, item 6). This thermostat senses water temperature flowing to the pad and will shut off the heater if the water temperature exceeds specific limits (120°F). The purpose of the limit thermostat is to prevent the pump from providing water at too high a temperature to the pad.
- The control of the selected temperature is performed by a dual thermistor (fig 8, item 1) Dual Processor design. The Control Processor reads its thermistor and determines if heat is required. If heat is required it sends a signal to an Over Temperature Processor. The Over Temperature Processor reads its thermistor, and insures the temperature is below the over temperature value, before it allows the heater (fig 8, item 5) to turn on.

FLUID SYSTEM:

The pump is a sump configuration magnetically coupled to an impedance protected, shaded pole AC Motor (fig 8, item 3).

The return hose fitting (fig 8, item 7) is machined internally to act as an orifice. This maintains a back pressure in the pad to make it resistant to flow restrictions.

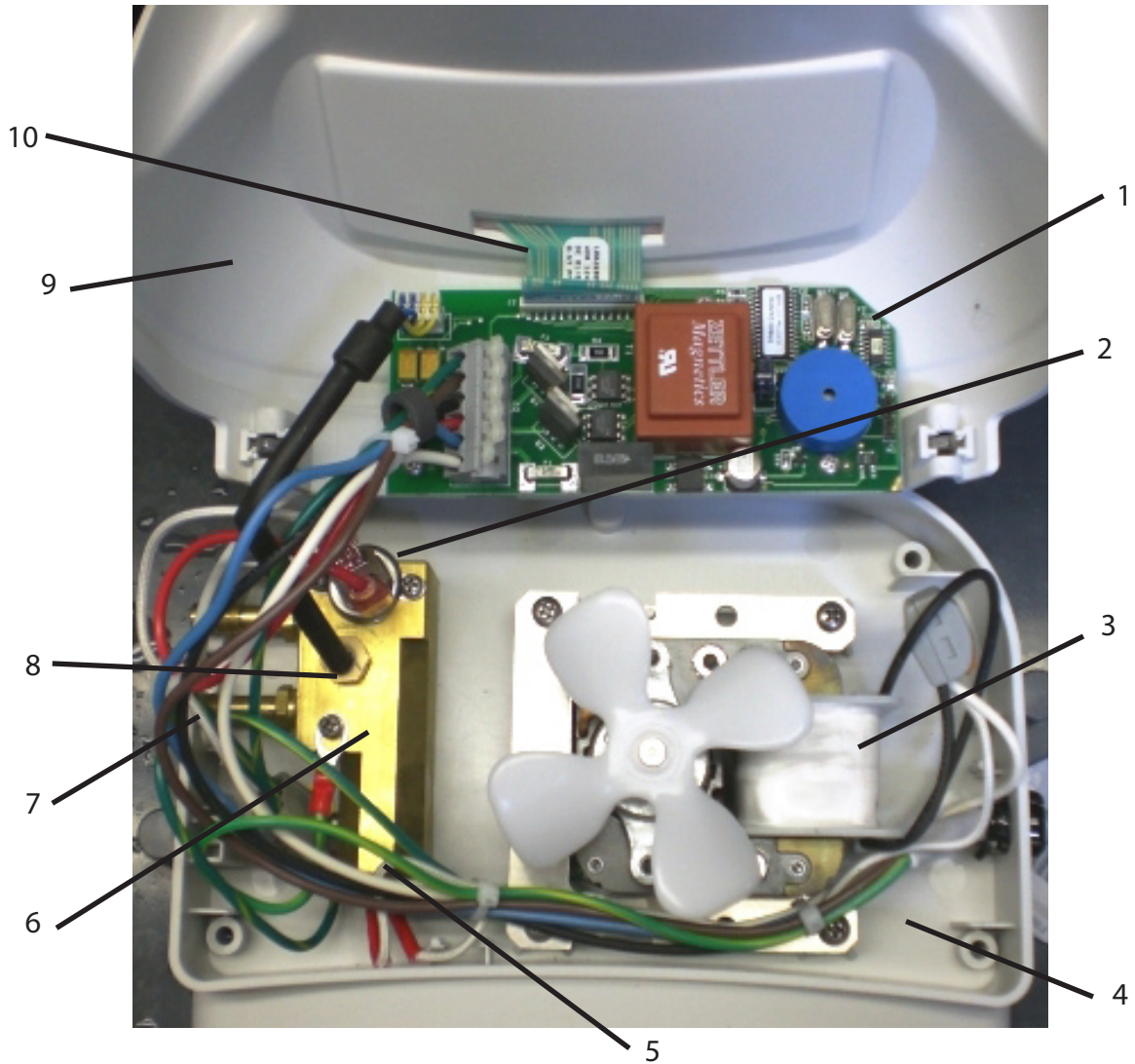

Item	Description
1	PC Board (Temperature Controller)
2	Manifold Backup Limit Thermostat
3	Pump Motor
4	Tray Assembly
5	Cartridge Heater
6	Brass Manifold Block
7	Return Hose Fitting
8	Temperature Sensor
9	Housing Front Assembly
10	Ribbon to Front Keypad

Figure 8: T/Pump Components

FUNCTIONAL CHECK

INTERVAL

REQUIRED
EQUIPMENT

WARNING

- Only qualified service personnel should perform this Functional Check. Improperly following the test procedure may result in equipment damage.
- Do not perform this Functional Check with an empty reservoir. Damage to the T/Pump may result.
- Read through and understand each step before performing the test.

To assure optimum performance, dependability and safety, the following Functional Check should be performed once per year (or as specified in the facility's preventive maintenance program).

- TFC1 or equivalent (Thermometer with 30° F to 125°F (-2°C to 52°) range with 2°F (1°C) accuracy.
- TPT9 is used to measure the temperature and the flow of the water entering the pad. (To use with Colder style connectors, also order adaptor hose P/N 77926-000.)
- Stop Watch for testing Over-Temperature Safety Circuit
- Mul•T•Pad
- Test Probe, T/Pump P/N:100925000

Note: To order a TFC1, TPT9, Test Probe and Mul•T•Pad, contact your dealer or Gaymar's Customer Service Department.

Figure 9a:
Functional Check
Setup (Clik-Tite)

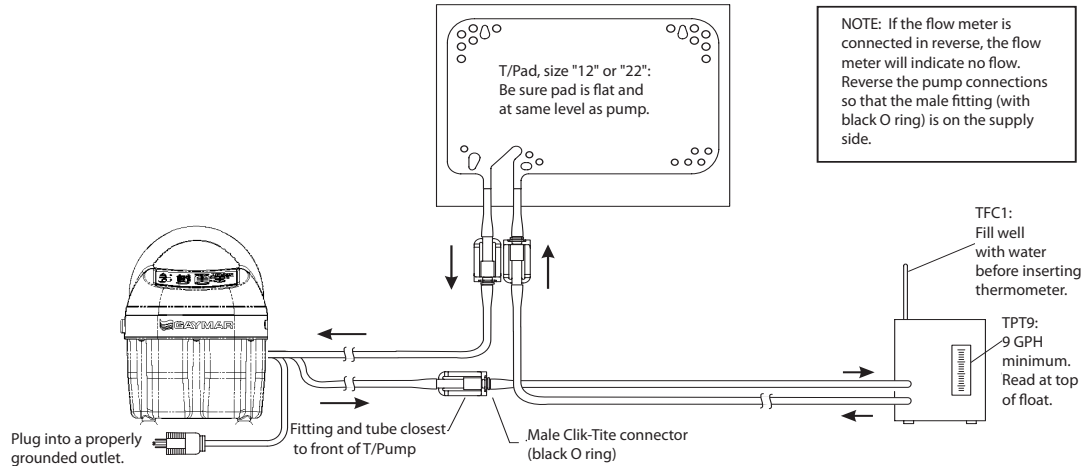
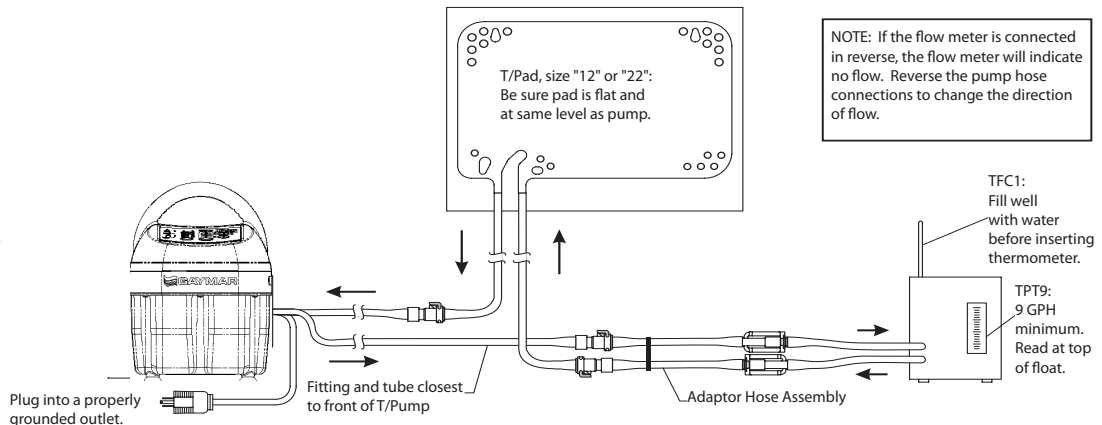

Figure 9b:
Functional Check
Setup (Colder)



Operating
Temperatures, Flow
and Over-Temperature
Safety Circuit Check

Test Setup

Physical Condition Check

Flow & Operating
Temperature Test

Note: If at any time the Function test needs to be stopped, press the On/Standby button.

This section provides a complete check of all T/Pump functions. Follow the steps in this section carefully, paying particular attention to each step, and its expected result. If at any time the expected result can not be verified, press the On/Standby button to stop the test, then restart the procedure. If after a second attempt the expected result can not be verified, press the On/Standby button to stop the test, then unplug the T/Pump and call your dealer or Gaymar's Technical Service Department for assistance.

Connect the T/Pump to the TPT9 and Mul•T•Pad as shown in Figure 9a, 9b.

1. Examine the plug and line cord along its entire length for physical damage, such as cuts or cracked insulation. A damaged line cord should be replaced rather than repaired. Check the quality of the strain relief of the line cord.
2. Examine membrane panel for cuts or cracks. If damaged, replace.
3. Visually inspect pump. Check for cracked or damaged plastic parts. Be sure unit is unplugged. Remove four (4) screws from the handle area. Remove four (4) screws securing upper housings to tray. Perform visual inspection of all internal parts. Remove any accumulated dirt with a vacuum cleaner or compressed air hose.
4. Check connectors for cracks, missing O rings, or other damage. Replace connectors if necessary.

Note: Stay present for the full duration of the test to observe all readings and to prevent damage to the T/Pump.

1. Attach a pad to the connector hose (See Figure 9a/9b). Then, unkink the pad and hose. Open the hose clamps.
2. Open the fill cap on top of the pump.
3. Fill with room temperature water to the Heating water line. 
4. Plug the T/Pump into a properly grounded Hospital Grade receptacle. The T/Pump performs its self test of the lights and audible alarm, with light pattern and short audible beep. The T/Pump goes to Standby mode with only the Standby light on.
5. Press the On/Standby button.
6. Press and hold the Temperature Setpoint button.
7. While still holding the Temperature Setpoint button, press the On/Standby button. Hold both buttons simultaneously for 3 seconds and then release.

The T/Pump gives a long audible beep, and the Warning light flashes.

The T/Pump goes into Operating Temperature Function Test mode, and the:

- T/Pump starts pumping with the Standby light on with a flow of 9 GPH minimum.
- 107°F (42°C) setting is selected.

- Continuous light is on (TP700 Series Only).
- System disables the Wave feature to maintain a steady 107°F supply of water to the pad.

The T/Pump controls to 107°F (42°C) at the inlet to the pad for 15 minutes, the duration of the test.

8. After 13 minutes, verify with the TPT9 that the Temperature is at 107°F +/- 2°F (42°C +/- 1°C) and flow is 9 GPH minimum.

Note: If the T/Pump does not reach the temperature and flow, press the On/Standby button, unplug the unit, check the pad and hoses for kinks and start over.

9. After 15 minutes, observe that the T/Pump starts the Over Temperature Safety Circuit Test.

The T/Pump gives a three long beeps with the Warning light on. This signals the start of the Over Temperature Safety Circuit Test.

10. Start the stop watch to make sure the Over Temperature condition is detected in 30 seconds.

WARNING: If this step is not followed, damage to the T/Pump may result.

- The T/Pump gives a long beep and flash of the Warning light.
- The pump stops. No water will be flowing to the pad.
- The Heater is turned on at 100% power with no flow.
- The 107°F (42°C) Setpoint light starts flashing.
- The 20-minute cycle light starts flashing (TP700 Series Only).
- When the T/Pump detects an Over Temperature Condition (temperature trip point of 115°F \pm 5°F [46°C \pm 2°C]), the T/Pump gives an audible beep and flashes the Warning light. The system then cycles and goes into Standby mode with the Warning light on.

11. When the Warning light turns on, stop the Stop-Watch.

12. Restart the Stop-Watch to make sure the T/Pump cools down to a point where the thermostat resets and the Warning light turns off in 60 minutes.

Or, to speed up the cool down, go to step 13.

13. To speed up the cool down:

- a. Unplug the T/Pump.
- b. Refill the reservoir with room temperature tap water.
- c. Restart the unit in Cooling mode.

The system starts cooling down in Standby mode. The thermostat resets within 5 minutes.

The test is completed.

14. Shut down the T/Pump as described on page 13.

BACKUP LIMIT THERMOSTAT TEST

This test is used to insure the temperature at the pad stays below a safe level in an over temperature condition.

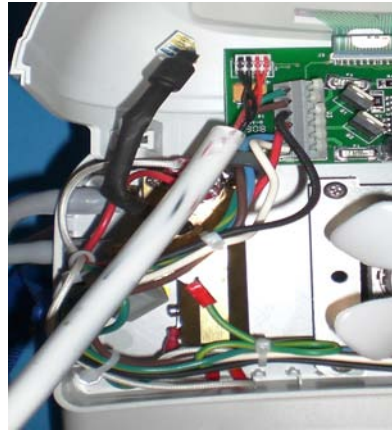

Figure 10: Connection of Test Temperature Sensor

Test Procedure:

1. To perform this test you will need to open the tray assembly (Refer to section DISASSEMBLY/REASSEMBLY) to install the Test probe, as shown in figure 10.
2. Attach a pad to the connector hose (See Figure 9a/9b). Then unkink the pad and hose. Open the hose clamps.
3. Open the fill cap on top of the pump.
4. Fill with room temperature water to heating water line.
5. Plug the T/Pump into a properly grounded Hospital Grade receptacle.

The T/Pump performs its self test of the lights and audible alarm, with light pattern and short audible beep.

The T/Pump goes to Standby mode with only the Standby light on.

6. Press the On/Standby button. The T/Pump starts running at the default Setpoint of 100°F (38°C). Note: The Control & Over Temperature processor are reading the room temperature. This makes the system "believe" it will always require the heater due to the temperature the processors read is below the required Setpoint. This will drive the water flowing through the system to a temperature that will "trip" the thermostat (in approximately 10 to 15 minutes). Record the peak temperature read by the thermometer. The temperature recorded must be between 108°F (42.2°C) and 119°F (48.3°C). If the thermostat operates outside its intended range, it must be replaced. After the thermostat "Trips" the system will cool down to a temperature that resets the thermostat (in approximately 20 to 25 minutes). This "Trip"/Reset cycle will continue until the unit is put back into Standby mode.
7. Press the On/Standby button. The T/Pump goes into Standby mode.
8. Unplug the T/Pump.
9. Unplug the Test probe, and plug the Original Temperature Sensor back in.
10. Close the unit. (Refer to section DISASSEMBLY/REASSEMBLY).

LEAK TEST

- Immediately upon completion of the previous test, tilt unit towards you so the front is down. Hold for three (3) minutes.
- Return the unit to upright position and carefully check the reservoir tray joint for leaks. Repeat process turning pump on back face. If leakage is found, refer to DISASSEMBLY/REASSEMBLY, Reservoir section.

⚠ DANGER

Risk of electrical shock. Be sure unit is unplugged when performing the ground resistance test.

GROUND RESISTANCE CHECK

1. Use a ground resistance meter to measure the resistance between the ground pin on the plug and the brass manifold block (fig 8, item 6). Contact is available through the hole where the hoses connect to the pump. This value should not be more than 0.5 ohm.

CURRENT LEAKAGE CHECK

It will be convenient to check current leakage at this point since the unit is full and connected to a pad.

1. Measure the maximum current leakage in all combinations of heater "ON" or "OFF" and On/Standby "ON" or Standby. Access to chassis ground for current leakage testing is available through the hole where the hose connects to the pump. The highest reading is typically less than 30 microamperes. The maximum allowable reading is 100 microamperes (200 microamperes for 230 volt model). Record the highest reading.
2. Disconnect leakage meter setup.

Inspection forms vary from hospital to hospital. The following sample form is intended as a guide so that the important parameters are recorded.

T/Pump Functional Check and Safety Inspection Form				
				Date: _____
		Model Number: _____	Serial Number: _____	
Item	Value	Okay	Action Needed?	Action Taken
		(check one)		
1	Inspect physical condition (line cord, plug, housing)			
	Inspect hose connections and connectors			
2	Measure flow, >9 gph (34 lph)...indicate value			
3	Measure operating temperature @ 107°F ±2°F...Indicate average			
4	Backup limit test 108°F - 119°F			
5	Leak Test			
6	Measure ground resistance, <0.5 ohm...indicate value			
7	Measure current leakage, <100µA (120 V), <200µA (230 V)			
Signature: _____				

Reservoir:

- Unplug the Unit.
- Drain the Reservoir.
- Remove the nine (9) screws which retain the Reservoir to the Tray assembly.
- Lift the Tray assembly from the Reservoir and set aside. Note: Be careful to keep the Upper Housing with the tray. It can be lifted from the tray, but there are wires connecting the two parts.

Upper Front & Rear Housing:

- Perform the Steps for Reservoir disassembly.
- Remove the four (4) screws from the back of the Upper Housing handle.
- Remove the Rear Housing to the Tray, or Front Housing.

PC Board:

- Perform the steps for Reservoir and Upper Front & Rear Housing disassembly.
- Lift the Upper Front Housing from the Tray assembly.
- Remove the Keypad Ribbon cable (Fig. 8, Item 10) from the PC Board (Fig. 8, item 1).
- Remove the Temperature Sensor (Fig. 8, Item 8) from the PC Board.
- Remove the 6 wires from the PC Board.
- Remove the 3 Screws from the PC Board.

Heater Kit Assembly:

- Perform the Steps for Reservoir and Upper Front & Rear Housing disassembly.
- Remove the two (2) screws from the Manifold backup limit thermostat (Fig 8, Item 2).
- Remove the 2 wires from the Cartridge Heater. One goes to the PC-Board, the other goes to a neutral wiring connector.
- Remove the Temperature Sensor (Fig 8, Item 8) from the Brass Heater Manifold.
- Cut the Gray Hose connected to the Brass Heater Manifold.
- Remove the two (2) brass fittings on the bottom of the Tray assembly which hold the brass manifold block to the tray.
- Discard the two (2) o-rings between the brass heater manifold and the tray assembly.

Heater Assembly:

- Perform the Steps for Reservoir and Upper Front & Rear Housing disassembly.
- Remove the 2 wires from the Cartridge Heater. One goes to the PC-Board, the other goes to a neutral wiring connector.

Remove the (2) brass fittings on the bottom of the Tray assembly which holds the brass manifold block to the tray.

To assembly, reverse the disassembly steps. Special attention is required for the following:

1. Gray hose can be placed in warm water ($\leq 50^{\circ}\text{C}$) to facilitate installation on manifold fittings.
 2. All o-rings must be seated. The reservoir o-ring is shaped, and shape must be aligned with the reservoir.
 3. All fittings on the manifold should have teflon tape applied to prevent leaks.
 4. Insure wires are cleared from between enclosures and away from enclosure screws.
 5. Insure wires are routed away from the cooling fan blades.
 6. For proper screw size and location for reservoir and housing, refer to parts illustration and replacement parts list.
-
-

TROUBLESHOOTING

Problem	Possible Cause	Remedy
T/Pump will not turn on.	The electrical cord is not plugged into a properly grounded Hospital Grade receptacle.	Insert the plug fully into the properly grounded Hospital Grade receptacle.
T/Pump will not pump.	Water level is low or reservoir is empty.	Refill with room temperature water to proper level.
Flow indicator light is on.	<p>Water flow to pad or hose is restricted.</p> <p>Clamp is closed.</p> <p>Water level is low or reservoir is empty.</p> <p>T/Pump is filled with water that is too hot.</p>	<p>Straighten the hose.</p> <p>Open the clamp.</p> <p>Refill with room temperature water to proper level.</p> <p>Refill with room temperature water to proper level.</p>
Warning indicator & Audible alarm (Flash / Beep).	<p>A High Heat (107°F / 42°C) or Cooling Setpoint was selected (50°F / 10°C).</p> <p>Loss of power while unit was in a Therapy mode. (Possible Power Fail.)</p> <p>Unit is running after a 20- or 30-minute "Off" therapy cycle period, has reached the desired Setpoint, and is now timing the 20- or 30-minute On cycle period (TP700 Series only).</p> <p>The unit just went into, or came out of Lock mode (TP700 Series only).</p> <p>Safety Circuit Function Test has started. Note: This would be followed with the unit starting, while still in Standby mode. See the Functional Check section for details.</p>	<p>Indication only: A Setpoint outside body temperature range is selected.</p> <p>Insert the plug fully into the receptacle, place the unit into Standby mode, then unplug the T/Pump. If power is removed while unit is in On-Mode, the Power Fail alarm will beep for approximately 10 minutes.</p> <p>Indication only to indicate an "On" Therapy cycle period is timing.</p> <p>Indication only.</p> <p>Note: This should only be performed by medical service personnel. If this mode was started in error, press the On/Standby button to stop the test and go back to Standby mode with the pump off.</p>

Problem	Possible Cause	Remedy
Both the Temperature and Therapy Cycle Setpoint lights are blinking (TP700 Series Only).	Unit is in "Off" Therapy cycle time.	Indication only.
T/Pump will not heat.	Reservoir is empty. Flow is blocked. Therapy Cycle is off.	Refill with room temperature water to proper level. Reference "Flow indicator light is on" above. Wait for therapy cycle on.
T/Pump will not cool.	Reservoir is empty. Flow is blocked. Ice is depleted.	Refill with room temperature water to proper level. Reference "Flow indicator light is on" above. Drain excess water to Cooling water line and fill remainder of reservoir with ice.
Temperature or Therapy Time buttons do not work (TP700 Series Only).	The buttons have been locked.	Press and hold the lock button for two seconds.
Water leaks from hose connectors.	Damaged O-ring. Locking ring on Klik-Tite® connector is not snapped into place (See Figure 6) Colder®-style connector not seated properly.	Replace Klik-Tite® connector. Male: P/N: 03887000 Female P/N: 038840000 Snap Klik-Tite® connector shut. Secure pad connection to pump (See Colder®-style Connectors) Replace connectors or pad if defective.

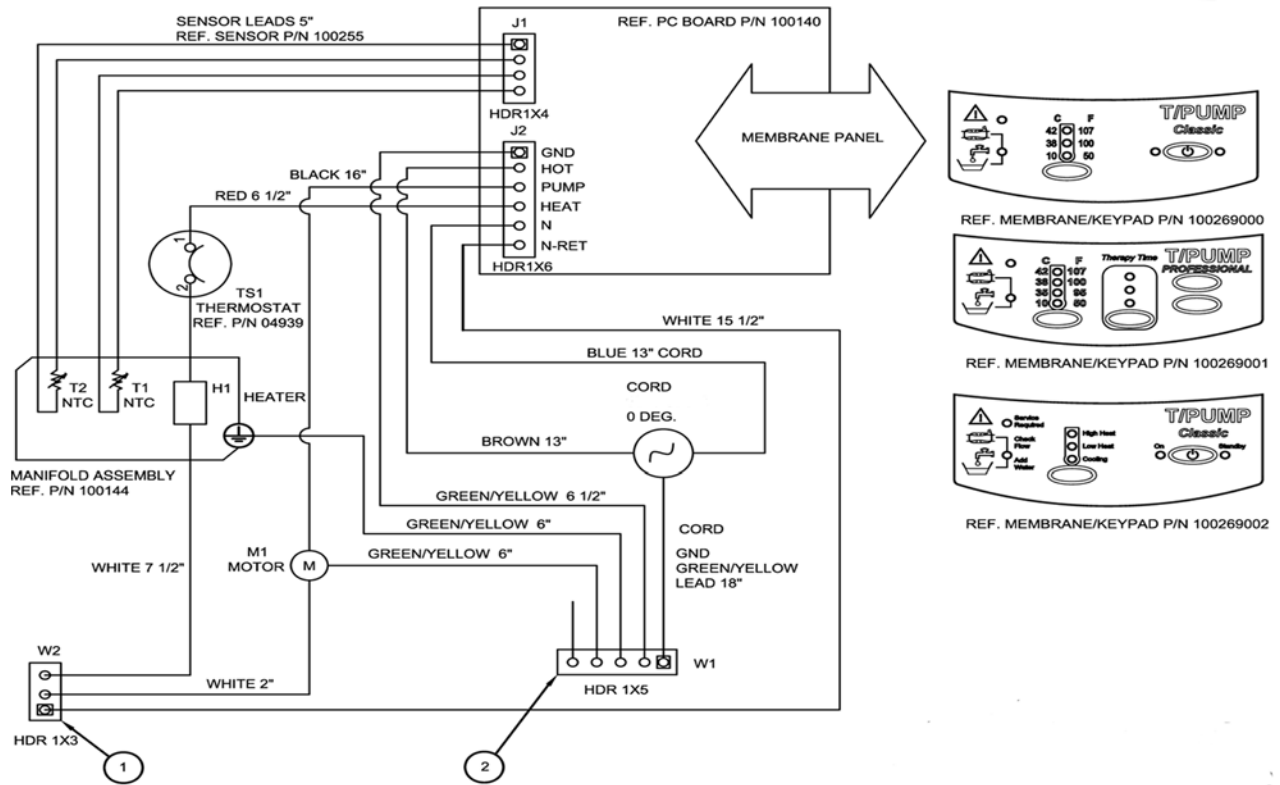

Figure 11: Wiring Diagram

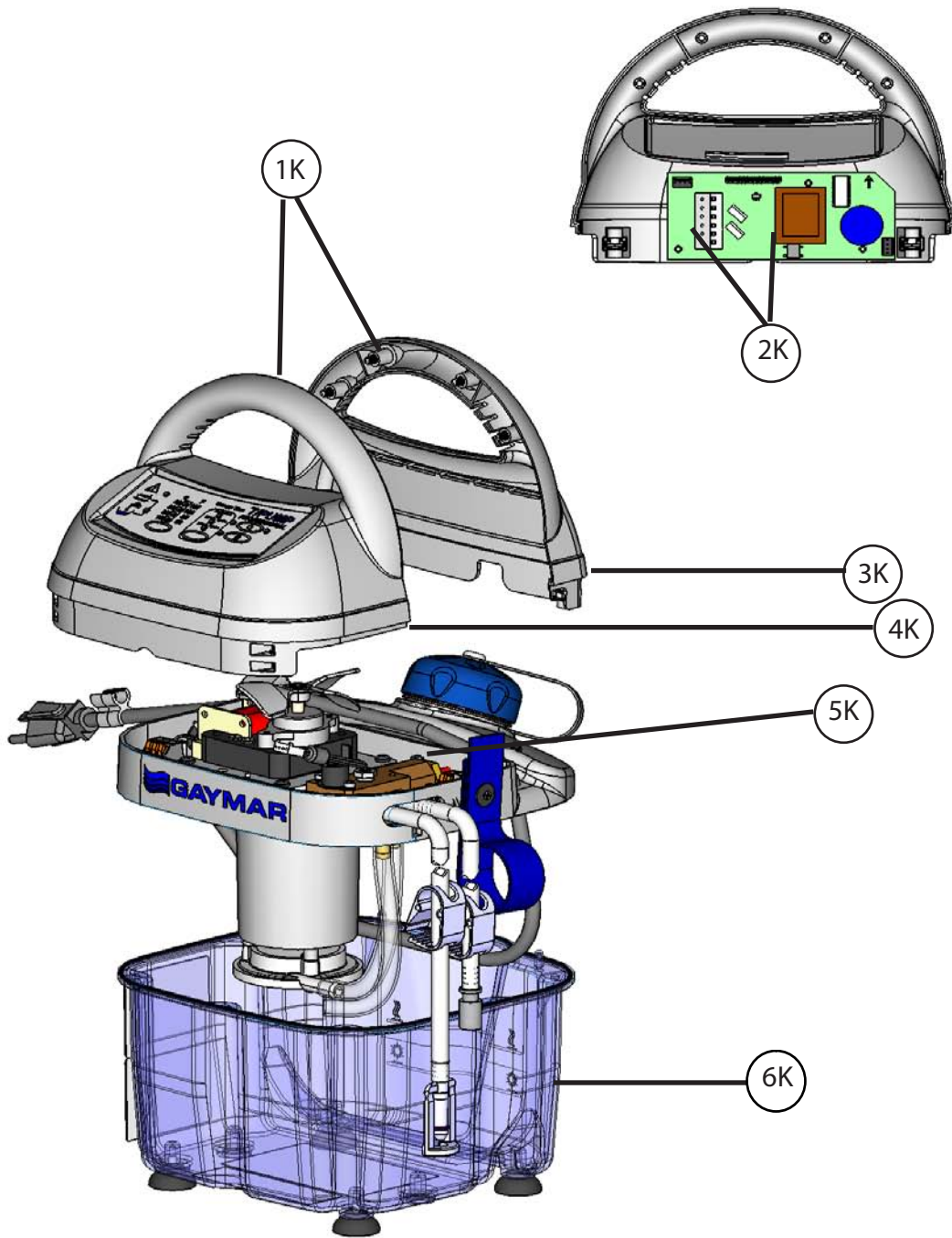

Figure 12: Parts Illustration for Kits

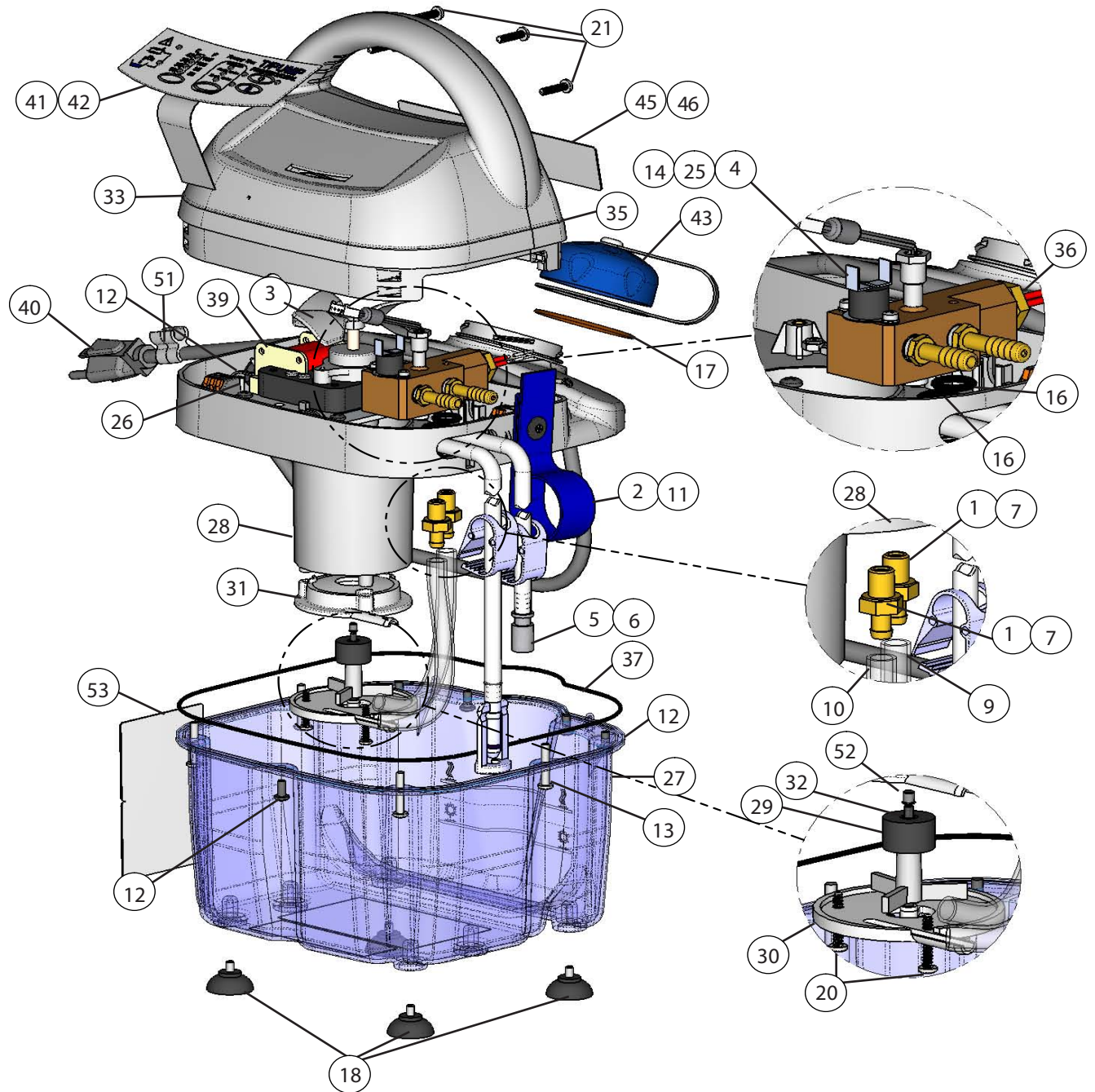

Figure 13: Parts Illustration Continued

REPLACEMENT PARTS LIST

SERVICE MANUAL TP600 & 700 Series T/PUMP

Item	PN	Qty	Description	Item	PN	Qty	Description
1K	TP650, 100822002 TP700, 100822001 TP702 100822000	1	KIT: Upper front & Rear Housing. Includes both Front & Rear plastic housing, Label, Keypad.	19	90514003	3	Screw Type "B1" Thread Cutting Pan HD SST. #4 x 3/8" LG
2K	TP650, TP700 100898000 TP702 100898001	1	KIT: PC Board/Sensor Assembly - This assembly comes with a pre-calibrated sensor and PCB assembly. They are a "Matched" set. Do <u>not</u> use the old sensor with the new PC Board or the old PC Board with the new sensor.	20	90514013	4	Screw Type "B1" Thread Cutting Pan HD SST. #6 x 7/8" LG
3K	TP650, 100819000 TP700, TP702 100819001	1	KIT: Upper Rear Housing Assembly. Includes Rear Plastic Housing with Label.	21	90514020	4	Screw Type "BT" Thread Cutting #8 x 3/4" LG
4K	TP650, 100818000 TP700, 100818001 TP702 100818002	1	KIT: Upper Front Housing Assembly. Includes Front Plastic Housing with Label.	22	90603000	1	Label Ground Identification
5K	TP650, TP700 100821001 TP702 100821002	1	KIT: Heater Assembly. Includes Brass Manifold, 2 O-Rings, 4 Fittings.	23	91275059	1	Screw, Mach, Flat C'Sunk HD, CR SST 6-32 x 3/8 LG
6K	100820000	1	KIT: Reservoir Assembly. Includes Reservoir, Gasket, Rubber Feet, Label.	24	91390000	1	Toroid, Ferrite Ring
1	03394000	1	Fitting, Manifold	25	91454052	2	Screw, Mach, Fillister Head #6-32 x 1/4 LG SST
2	03791001	2	Strap Hose - Hose	26	100092000	2	Connector Lever Nut 3 Terminal
3	04152000	1	Fan	27	100127000	1	Reservoir
4	04939014	1	Thermostat, Sort	28	100129000 TP702 100129001	1	Tray Assembly
5	08086000	1	Hose Assembly - Klik Tites	29	100130000	1	Impeller/Magnet Assembly
6	08648000		Hose Assembly - Colders	30	100132000	1	Impeller Housing Bottom
7	Source Locally	3	Tape, Teflon, 1/4" Wide	31	100133000	1	Impeller Housing Top
8	Source Locally	4	Ty-Wrap, Self Locking	32	100134000	1	Pin, Impeller
9	81002000	1	Tubing, PVC, Panacea 1/4 ID x 3/8 OD x 3 1/2" LG	33	100139000	1	Housing, Front Assembly
10	81002000	1	Tubing, PVC, Panacea 1/4 ID x 3/8 OD x 6" LG	35	100142000	1	Housing, Rear Assembly
11	90018029	1	Screw, Machine 4-40 x 1/2" FH Phillips	36	100144000 TP702 100144001	1	Heater Assembly 120 VAC Heater Assembly 230 VAC
12	90018075	9	Screw Mach PH CR 8-32 UNC 2A x 3/8 LG S	37	100152000	1	O-Ring, Reservoir
13	90018082	4	Screw, Machine Pan HD #8-32 x 1 SST	39	100261000 TP702 100261001	1	Motor/Plate Assembly
14	90049005	2	LockWasher, Spring #6 SST	40	100267000 TP702 10053-EURO	1	Cord, Power Assembly (Gray)
15	90076018	1	Bushing, Straight Thru (HEYCO #1210)	41	100269001	1	Membrane Panel - Professional
16	90295019	2	O-Ring	42	100269002	1	Membrane Panel - Classic
17	90295020	1	O-Ring, Silicone	43	100269003	1	Membrane Panel - CE
18	90385000	4	Cup, Suction	44	100275000	1	Cap, Teathered, Rivet Assembly
				45	100283000	1	Magnet Driver Assembly
				46	100286000	1	Label, Instruction TP600 Classic
				47	100286001	1	Label, Instruction TP700 Professional
				48	100289000	1	Label, Ratings Classic
				49	100289001	1	Label, Ratings Professional
				50	100289002	1	Label, Ratings Classic W/Colder
				51	100289003	1	Label, Ratings Professional W/Colder
				52	100292000	1	Clip, Cord
				53	100378000	1	Cap
				54	100578000	1	Label, Danger

WARRANTIES

GAYMAR equipment and products are warranted against defects in material and workmanship under normal use, and operation from the date of purchase, for the time periods listed below for the respective equipment and products. Except for such warranty, GAYMAR disclaims all other expressed and/or implied warranties including, but not limited to, the implied warranties of merchantability and of fitness for a particular purpose.

PUMP

All labor performed and parts provided free of charge for a period of one (1) full year from the date of purchase, provided the equipment is returned with prior authorization prepaid to GAYMAR Industries.

PAD, SINGLE PATIENT
USE

Free replacement of product where defects in materials and/or workmanship are evident at time of delivery, provided the product is returned with prior authorization prepaid to GAYMAR Industries.

PAD, REUSABLE

Free replacement of product where defects in materials and/or workmanship occur within 90 days from date of delivery, provided the product is returned with prior authorization prepaid to GAYMAR Industries.

PARTS

Defective parts will be exchanged free of charge where defects in materials and/or workmanship occur within 90 days from date of delivery, provided the parts are returned with prior authorization prepaid to GAYMAR Industries.



GAYMAR INDUSTRIES, INC.

T/PUMPS® AND T/PADS®
ARE MADE IN THE USA