

The Theratrak Pro is a patented device that is designed to gently lift the user's torso by means of vertical air columns. It is lightweight, thin and easy to use. Theratrak Pro allows mobility and stabilization of the back to help alleviate pain and prevent injuries. It may be worn under clothing to allow performance of daily activities such as driving, walking and standing for extended periods of time. Active lifestyles, including sports and leisure activities may be enjoyed using the Theratrak Pro. The effect of the Theratrak Pro, when worn between the lower part of the rib cage and the top of the hip, is a traction lift to reduce pressure in the lumbar region. The vertically expandable air columns provide lumbar spinal decompression to eliminate lower and radiating pain.

COMPONENTS + ACCESSORIES

- *Theratrak Pro Lumbar Decompression Brace*
- *User instructions-cautions, warnings and operating instructions*

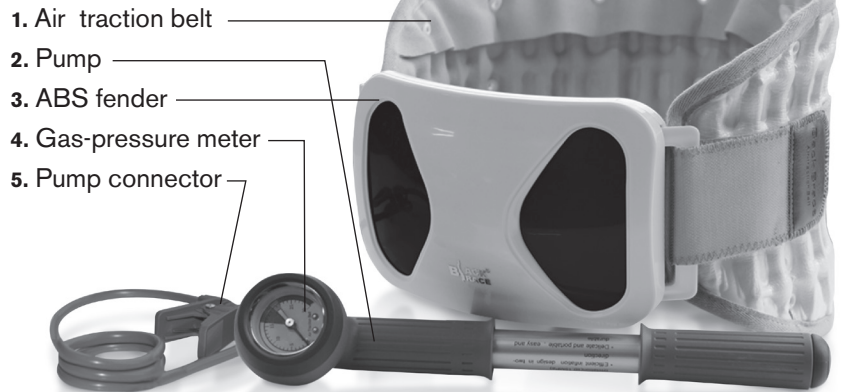

1. Air traction belt
2. Pump
3. ABS fender
4. Gas-pressure meter
5. Pump connector

INDICATIONS FOR USE

The Theratrak Pro can be used for pain relief, muscle relaxation and stretching, posture improvement, and a variety of other pain conditions.

- *Decompression of the spine*
- *Sciatica*
- *Spinal stenosis*
- *Degenerative disc disease*
- *Lumbar pain acute and chronic*
- *Bulging discs and more...*

SIZING

(waist circumference at the navel)

LT100SMMD - Small/Medium – 30.1-38"

LT100LGXL - Large/XLarge – 40.5-47.2"

You must read all instructions and cautions and warnings before using:

DO NOT WEAR THERATRAC PRO WHILE EATING OR FOR 1 HOUR FOLLOWING A MEAL.

1. Remove any jewelry, earrings, necklaces, eyeglasses or any other item that could get in the way of therapy
2. Wear directly against the skin or over very thin clothing
3. Make sure to size the product according to the sizing chart
4. Wrap the un-inflated belt around the waist, between the lower rib cage and hip, centering the ABS fender in front of the navel

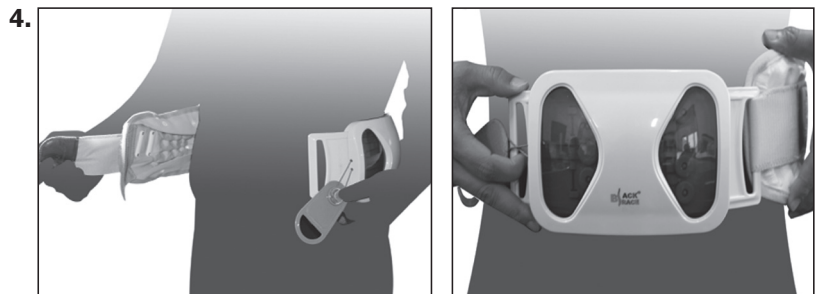

(continued on back)

5. Pull the band through one opening of the front fender and secure velcro to hold belt in place
6. Use the pull ring to get a tighter fit to the body.
7. Attach the control valve from the air pump to the fill valve using the butterfly clip (image 10)
8. Relax yourself through breathing, and release any tension in your body
9. In fact, stay as relaxed as possible throughout all facets of traction therapy for optimal results
10. While staying in a relaxed position, begin pumping the pump. You will begin feeling a stretch in your lower back. Pump to your comfort and leave in place for a continued anti-gravity lift.
11. To deflate the brace, remove the butterfly clip and twist the knurled area of the fill valve that extends from the brace, counter clockwise. The air will release, and then tighten the knurled area (clockwise) so it is ready to inflate.
12. For at least the next hour after therapy, try to not make any abrupt motions with your back.

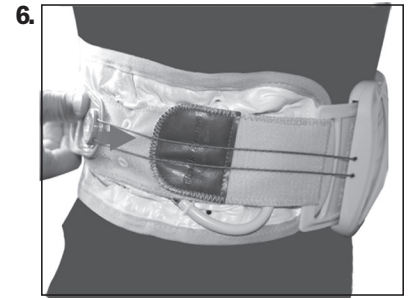
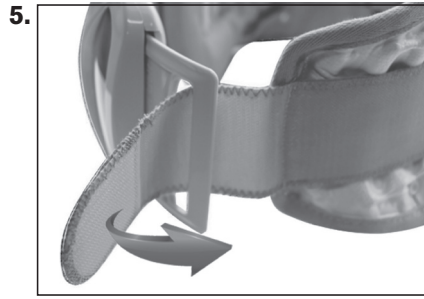

NOTE: For more of a traction treatment, which would entail a repetitive stretch and relaxation, you will pump, and then deflate and then repeat over a series of intervals to achieve such a result.

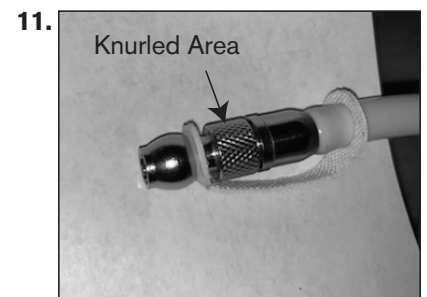

CAUTIONS AND WARNINGS

- Consult with your physician before using this product, especially patients with heart disease and/or hypertension, spinal cord compression.
- Consult your physician if you have spinal cord compression
- Do not exceed 14 psi while inflating this device.
- Do not sleep while wearing the device.
- Must remove all jewelry and loose clothing before using this device
- Avoid device contact with sharp objects.
- Use caution if you suffer from severe rheumatoid arthritis or inflammatory disease.
- Use caution if you have serious pathology
- Do not use if you are pregnant.
- Do not use traction if you have an infection or a disease malignancy
- Do not use traction if you have spine damage caused by tuberculosis or tumors.
- Do not use traction if you fractures or extruded disc fragmentation.
- Do not use if you have lumbar spine stenosis, acute lumbar injuries or severe osteoporosis
- If you experience dizziness, nausea, undue discomfort, or numbness, discontinue use of the product and contact your physician immediately.
- If you experience or feel any adverse reactions to this product, discontinue use of the product and contact your physician immediately.
- If you experience additional pain from using the device, discontinue use of the product and contact your physician. Check with your physician or healthcare provider for details on application, treatment times, and further advise as it applies to your condition.
- Handle with care. Avoid dropping pump.
- Avoid direct sunlight and heat exposure

CLEANING INSTRUCTIONS

With a clean damp cloth and some mild cleaning detergent, wipe down the brace and hand pump. Do not bleach or machine wash. Air dry.

WARRANTY INFO

The Theratrac Pro is covered by a 1 year warranty against all mechanical or manufacturer defects, from the date of purchase.