



ISO 9001-2008 CERTIFIED

CARE CLINER[®] COLLECTION

**OWNER'S OPERATING &
MAINTENANCE MANUAL**



PLEASE DO NOT DISCARD THIS MANUAL! KEEP FOR FUTURE REFERENCE AND TRAINING

TABLE OF CONTENTS/WARRANTY

Manual is for Models: 6530,6531,6540,6541,6550,6551,6570,6571,6700,6704,6710,6714,6740,6750,6900,6910,6940,6950

IMPORTANT SAFETY INFORMATION.....	2-3
ASSEMBLY INSTRUCTIONS.....	4
OPERATING INSTRUCTIONS.....	5-8
GENERAL MAINTENANCE.....	9-10
PARTS LIST GUIDE / SPECIFICATIONS.....	11-12
HEAT & MASSAGE OPERATING INSTRUCTIONS.....	13
OPTIONS FOR CARE CLINERS.....	14
CONTACT & WARRANTY INFORMATION.....	BACK COVER

UNPACKING

1. CAREFULLY EXAMINE YOUR PRODUCT FOR ANY DAMAGE. INSPECT ALL COMPONENTS.
IF DAMAGE IS EVIDENT, CONTACT FREIGHT CARRIER OR WINCO IMMEDIATELY.
2. REMOVE ALL PACKING MATERIAL AND HARDWARE THAT WAS SECURED FOR SHIPPING.
3. CAREFULLY REMOVE ALL OF THE COMPONENTS FROM THE CARTON.
4. SAVE ALL BOXES AND PACKING MATERIAL UNTIL AFTER YOU HAVE ASSEMBLED YOUR PRODUCT AND HAVE VERIFIED THAT ALL COMPONENTS ARE FUNCTIONING PROPERLY.

(IF DAMAGE IS EVIDENT, CONTACT THE FREIGHT CARRIER OR WINCO IMMEDIATELY!)

Winco assumes no responsibility for damage or injury caused by the improper assembly, installation, use or maintenance of these products.

IMPORTANT!

PLEASE READ THIS ENTIRE MANUAL BEFORE USING CHAIR. DO NOT INSTALL, MAINTAIN OR OPERATE THIS EQUIPMENT WITHOUT READING AND FOLLOWING THIS MANUAL. OTHERWISE INJURY AND/ OR DAMAGE MAY RESULT.

THE INFORMATION CONTAINED IN THIS MANUAL IS SUBJECT TO CHANGE WITHOUT NOTICE. **SAVE THESE INSTRUCTIONS FOR FUTURE REFERENCE!**

NO PART OF THIS MANUAL MAY BE DUPLICATED IN ANY FORM WITHOUT THE PRIOR CONSENT OF WINCO MFG, LLC. UNAUTHORIZED DUPLICATION MAY RESULT IN CIVIL PROSECUTION TO THE MAXIMUM EXTENT ALLOWED BY LAW.

Products with the following markings are intended for commercial use only.

 (MDD 93/42/ECC
MDSS GmbH
Burckhardtstr. 1
D-30163 Hannover
Germany

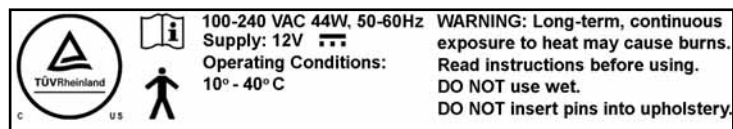

SYMBOLS



FOLLOW INSTRUCTIONS



DC VOLTAGE



TYPE B APPLIED PART



GENERAL WARNING SIGN

IMPORTANT - PLEASE READ



FOR PRODUCTS WITH POWERED OPTIONS (Heat, Massage, etc...)

Read all instructions before using this product.

IMPORTANT SAFETY INSTRUCTIONS - SAVE THESE INSTRUCTIONS

To reduce the risk of electric shock when using an electrical appliance, basic precautions should always be followed, including the following:

DANGER - Always unplug this product from the electrical outlet before cleaning, maintenance or when putting on or taking off parts.

WARNING:

1. Unplug this product from the electrical outlet if this product is not to be used for extended periods of time.
2. Supervision should be provided when this product is used by, on, or near children, invalids, or disabled persons.
3. Use this product only for its intended use as described in this manual. Do not use attachments not recommended by the manufacturer.
4. Never operate this product if it has a damaged cord or plug, if it is not working properly, if it has been dropped or damaged, or dropped into water. Return the product to an authorized Winco service center.
5. DO NOT carry or pull this product by power supply cord or use the cord as a handle.
6. Keep the cord away from heated surfaces.
7. Do not use outdoors.
8. To disconnect, turn all controls to the "off" position, then remove plug from outlet. Do not "yank" cord.
9. Clean switch with a damp cloth only – Warranty will be VOID if liquid is introduced into switch mechanism.
10. Use only a certified extension cord that is rated at 15 amperes; extension cords rated for less amperage may over heat. Care should be taken to arrange the cord so that the cord cannot be pulled or tripped over.
11. DO NOT run recliner or other equipment over cord.
12. Recliner comes with a grounded three blade plug, if the plug does not fit into the outlet; contact a certified electrician to install the proper outlet. DO NOT MODIFY THE PLUG IN ANY WAY.

DANGER:

- i) Never insert pins, or attach other metallic fasteners into/onto the upholstery of this chair.
- ii) Do not use this product if the covering shows signs of deterioration, such as checking, blistering, or cracking.
- iii) KEEP DRY - Do not operate in a wet condition or environment.

WARNING:

- i) Long term, continuous exposure to heat may cause burns. It is recommended that skin in contact with heated area be checked for redness and blistering during long term usage. Do not use on an infant, invalid or unconscious person. Do not use on insensitive skin or on a person with poor blood circulation. If you are uncertain if you should use this product, please consult your physician about the use of heat and massage.
- ii) Do Not Crush/Pinch heating elements or wiring.

WARNING: Connect this product to a properly grounded outlet only. (see grounding instructions, pg 3)

IMPORTANT - PLEASE READ



GROUNDING INSTRUCTIONS:

This product must be grounded. If it should malfunction or breakdown, grounding provides a path of least resistance for electric current to reduce the risk of electric shock. This product is equipped with a cord having an equipment-grounding conductor and a grounding plug. The plug must be plugged into an appropriate outlet that is properly installed and grounded in accordance with all local codes and ordinances.

DANGER - Improper connection of the equipment-grounding conductor can result in a risk of electric shock. Check with a qualified electrician or serviceman if you are in doubt as to whether the product is properly grounded. Do not modify the plug provided with the product - if it will not fit the outlet, have a proper outlet installed by a qualified electrician.

This product is for use on a nominal 120-volt circuit and has a grounding plug. Make sure that the product is connected to an outlet having the same configuration as the plug. No adapter should be used with this product.

For an added level of safety; Winco recommends the use of a 120 volt GFCI (ground fault circuit interruptor) outlet.



WARNING

DO NOT LIFT OR CHANGE CHAIR POSITION BY USING THE LEGREST. THIS COULD CAUSE INJURY TO USER OR DAMAGE TO THE RECLINE MECHANISM AND WILL VOID WARRANTY. ALWAYS CHANGE POSITION FROM BACK OF CHAIR.

1. READ AND FOLLOW ALL DIRECTIONS.
2. Keep children away from extended foot support (or other similar parts).
3. **DO NOT** put hands, feet or clothing into any openings when changing positions on recliner. Attendant **MUST** confirm that users arms, legs, hands and feet are safe while changing recliner positions or **SERIOUS INJURY MAY RESULT**.
4. Lock casters at all times, except when transporting chair.
5. **STAY CLEAR** of the recliner mechanisms.
6. **DO NOT** use recliner for transporting in or with **ANY** type of vehicle or trailer. Winco recliners have not been tested or approved for use by an occupant in any type of vehicle or trailer.
7. **NEVER** use the chair arms or backrest as a seat; **SERIOUS INJURY** or damage may occur.
8. Periodically check the tightness of all nuts, bolts and screws.
9. Immediately **REMOVE FROM SERVICE**; Any recliner with broken recline mechanisms, torn upholstery, or other mechanical or visible damage.
10. **NEVER** transport user with chair arms in an "open or down" position. *Applies to Drop-Arm & Swing-Arm models.*
11. **USE ONLY WINCO AUTHORIZED REPLACEMENT PARTS.**
12. **NEVER EXCEED** the recommended weight capacity - see pages 11-12.

ASSEMBLY INSTRUCTIONS

BACK ASSEMBLY INSTRUCTIONS

1. Remove back assembly and chair frame from carton.

NOTE: Heat Only and Heat & Massage chairs, AVOID disconnecting any "chair to back" wires.

NOTE: Make sure the footrest is in closed position before installing the back.

2. Lock all casters on chair base. (see Lock/Unlock Casters page 6)

3. If your chair is a 653# or 654# model, see side panel removal on PAGE 7.

4. Remove ALL sets of clevis & bow-tie cotter pins located on the bottom L&R Forks of the Back Frame and on the operator of the gas cylinder. **DO NOT LOSE THESE PARTS, YOU WILL NEED THEM AGAIN! (FIG. 1)**

5. Position the Back Frame Forks (see diagrams pages 11 & 12) over the Seat Frame Rails and align holes (FIG 1).

HELPFUL HINT: Align holes on Lower Back Frame while allowing the Upholstered Back to rest on the seat; This will help you steady the chair back.

****If possible have someone help you hold the back assembly while you install pins****

6. Align & insert clevis pins (removed in step 4) through each Back Frame Fork and corresponding hole in the Seat Frame.

•The small hole in the clevis pin MUST be to the INSIDE of the chair. (FIG.2)

•**MODELS 670,671, 690, & 691 ONLY:** The clevis pin can only be installed with the small pin hole to the OUTSIDE of the chair.

•**MODELS w/ Heat or Heat & Massage:** The wiring from the back should be positioned between the back frame and the upholstered seat. (FIG.2A)

•Make sure pin goes through holes in seat frame tube, NOT UNDER SEAT FRAME TUBE.

•Insert bow-tie cotter pins into small hole of each clevis pin. (FIG.2B)

7. Align Operator holes between the Seat Frame bracket holes on Seat Frame assembly. Install the saved clevis and bow-tie cotter pin through the aligned holes. (FIG. 3)

WARNING

Make sure all bow tie cotter pins are securely inserted in all clevis pins and that cable end is attached through slot of Operator. Failure to securely insert the bow tie cotter pins into the clevis pin could cause the clevis pins to fall out and result in injury or damage to the chair.

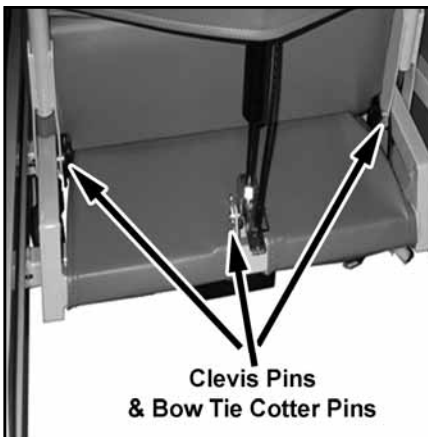
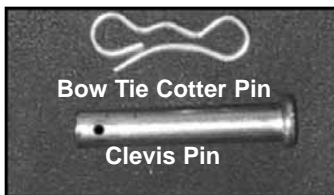

FIG. 1

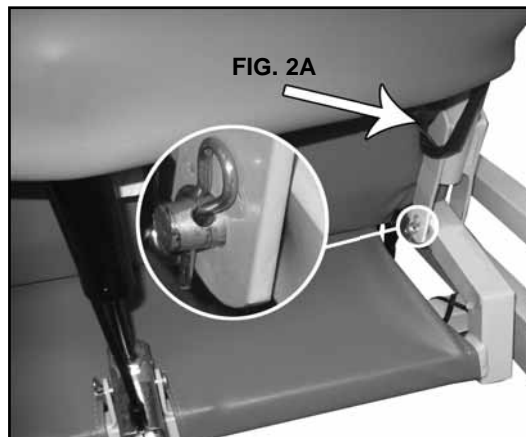

FIG. 2

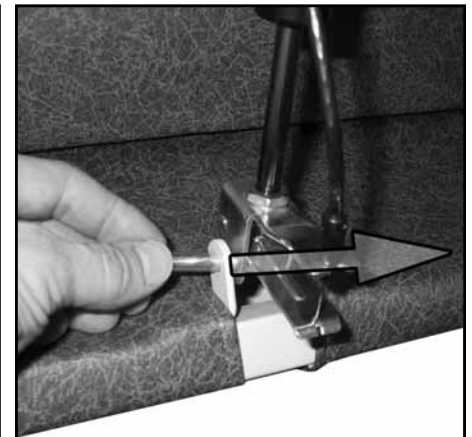

FIG. 3

OPERATING INSTRUCTIONS

RECLINING THE CARE CLINER

ALL CHAIRS HAVE 3 STANDARD POSITIONS PLUS TRENDELENBERG POSITIONING*

(*WHEN GAS SPRING IS ENGAGED FROM 3rd RECLINE POSITION)

1. From the #1 (SEATED UPRIGHT) position, grip the arm rests and simultaneously lean body weight back. Push rearward with your arms until desired recline position #2 (TV) or #3 (RECLINE) is reached. **(FIG.1)**

NOTE: The footrest will automatically elevate.

2. An attendant can also recline the chair to position #2 or #3 by simply grasping the armrest with one hand, *AND* the top of the chair back with the other; Then push down on the back of the chair. **(FIG.2)**

NOTE: This applies *ONLY* to positions 2 & 3, and *NOT* engaging the gas spring for trendelenburg.

3. **TRENDELENBURG POSITIONING** can *ONLY* be performed by an attendant. The gas spring **MUST** be engaged by squeezing the Release Handle at the top of the backrest. **(FIG. 3 & 4)**

DO NOT FORCE back of chair downward without squeezing the Release Handle. This can damage the chair . The chair back will stay in trendelenburg position when you remove your hands from the Release Handle.

4. Return the chair back to regular positioning by squeezing the Release Handle and lifting up until chair back is fully upright.

IMPORTANT: Attendant must return the chair back to the full upright position after patient exits chair & before another patient enters chair.



NOTE: If the chair back does not recline when the release bar is squeezed, or does not remain in correct recline position when the release handle is released, cable tension must be adjusted. Refer to Adjusting Gas Spring on page 9.

DO NOT push or pull footrest to position chair.
DO NOT stand or sit on the footrest or legrest.
DO NOT place hands, legs or feet under seat, legrest or footrest. Stay clear of recline mechanism.
KEEP CHILDREN AWAY from the underside of chair. Injury may occur.



FIG. 1



FIG. 2



FIG. 3



FIG. 4

OPERATING INSTRUCTIONS (cont'd)

LOCK/ UNLOCK CASTERS (FIG.1 - FIG.4)

(For 3" & 5" Nylon Casters and 5" Steel Casters)

1. **Total-Lock casters** will lock wheel and swivel mechanism by using your foot & pushing down on the tab.

Location: Nylon Casters-All front and RIGHT rear (LIGHT GREY TAB FIG.1 to FIG.2)

Steel Casters-All 4 casters (FIG.3 to FIG.4)

Directional-Lock caster aids with the steering of the chair.

NOTE: *The directional-lock tab ONLY prevents the caster from swiveling. This caster can be installed on the FRONT-LEFT side of chair as a steering option.*

Location: Nylon Casters-Left rear ONLY (FIG. 1)

Steel Casters-NOT AVAILABLE

Wheel-Lock casters (3" BLACK casters only) will lock wheel but does NOT prevent wheel from swiveling. Using your foot, push down on tab.

Location: All 4 BLACK casters installed on chair. (FIG.5 to FIG.6 or FIG.7 to FIG.8)

!!WHEN CHAIR IS STATIONARY LOCK ALL CASTERS!!

2. Release the locking mechanisms for ALL casters by pushing the above described tabs back to their upward position. (NYLON FIG. 2 to FIG. 1), (STEEL FIG. 4 to FIG. 3), (3" BLACK FIG.6 to FIG.5 or FIG.8 to FIG.7)

NOTE: *All 3" BLACK casters are wheel locking ONLY. They DO NOT have a TOTAL and DIRECTIONAL lock feature.*

RAISE/ LOWER DROP-ARMS (FIG.9)

(For Drop-Arm Care Cliner Models ONLY)

BEFORE RAISING OR LOWERING, BE SURE USER IS CLEAR OF DROP-ARM.

1. **To Lower:** Grasp armrest in center; use free hand to LIFT the Drop-Arm Release Handle. Drop-Arm will disengage and you can then lower it to the fully dropped position. (FIG. 9)
2. **To Raise:** Firmly pull straight up in the center of the armrest. Make sure both armrests are locked into place before transporting user.

NOTE: Periodically lubricate the channels of the drop arms with your approved silicone base lubricant spray to keep the parts moving freely.



WARNING

DO NOT raise & lower Drop-Arms with tables in an upright position. (Drop-Arm Care Cliner Models ONLY)

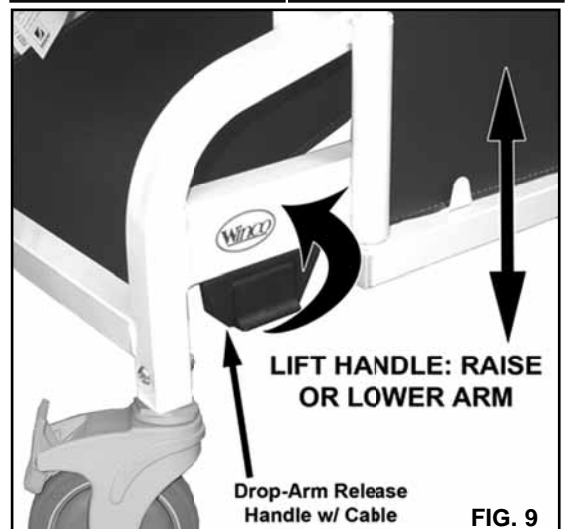
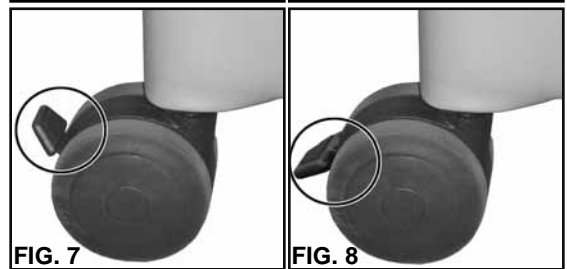
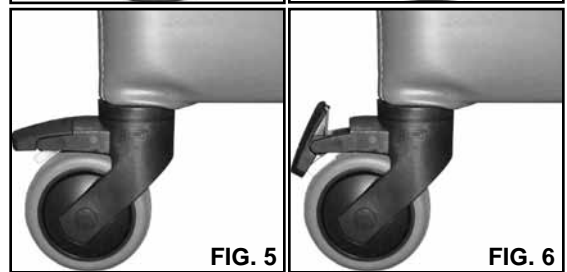
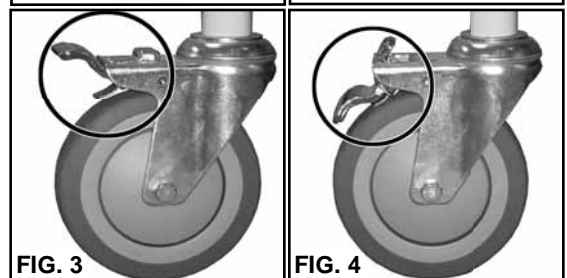
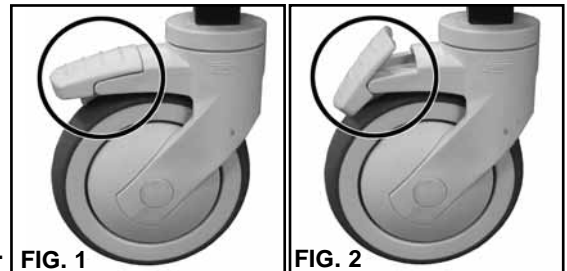

OPERATING INSTRUCTIONS cont'd.

SIDE PANEL - REMOVAL / REPLACEMENT

(For Care Cliner Models ONLY)

1. For ease of cleaning and chair maintenance; Unscrew two (2) thumbscrews at the front of chair and one (1) thumbscrew at the rear of chair, on inside of each panel. **(FIG. 1)**
2. Replace panel and re-install three (3) thumbscrews & clear washers **(FIG.2)** when cleaning or maintenance of chair is complete.

DROP-ARM VINYL PANEL

(For Drop-Arm Care Cliner Models ONLY)

1. The vinyl panel is secured to the bottom of the Drop-Arm with a hook & loop fastener material. Peel hook & loop apart to allow ease of cleaning and access behind the Drop-Arm of the chair. **(FIG. 3 & 4)**
2. Re-attach by aligning and firmly pressing the hook & loop material back together.

SWING-ARM OPERATION

(For Models: 6740-6750-6940-6950 only)

1. To open, depress the red latch handle to unlock the swing-arm. **(FIG. 4)**
2. To close, push swing-arm toward latch until latch engages. **(FIG. 4)**

WARNING

6740 & 6750 Models

DO NOT have an attendee in the trendelenburg position (pg.5) while both swing-arms are open. May cause tipping of chair.



FIG. 2



FIG. 3

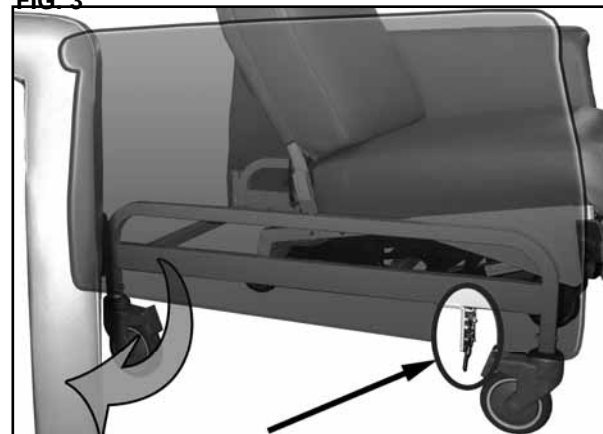

FIG. 4

OPERATING INSTRUCTIONS

TO POSITION SIDE TABLES (FIG.1)

1. To raise table, grasp center of table and gently raise into place. Table will automatically lock into place when released.
2. To lower table, grasp table at the center, raise and pivot down in one movement.

PIVOT TABLE (FIG.3)

“Lap” Position

1. To place pivot-table in “lap” position, pivot the table away from chair and pull over lap.
2. Tighten star-knob to secure the pivot-table in the lap position

“Exit” Position

1. With the table in the “lap” position, loosen star knob & push table away to exit chair.

Remove Pivot-Table

1. Loosen pivot-table star knob
2. Pull up on pivot-table until the table stem comes out of the black bracket.

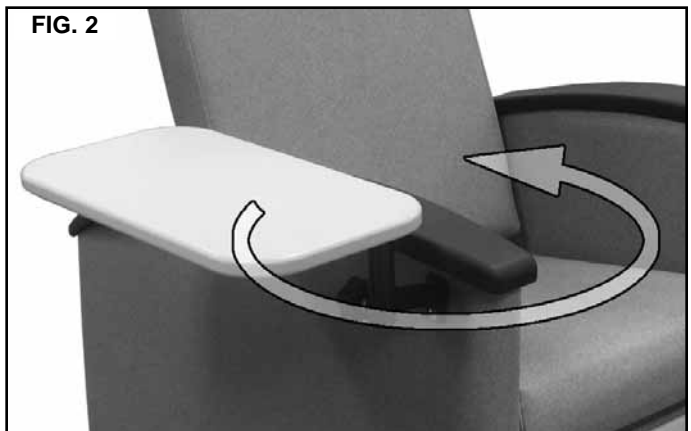

WARNING

DO NOT lean or sit on side tables.
Tables may break and cause injury.
DO NOT allow patients to raise from chair using side tables.

GENERAL MAINTENANCE

ADJUSTING GAS SPRING

NOTE: Tension or "ease of movement" of the gas spring is set by factory and cannot be changed. The following instruction is for adjusting the gas spring "release and engagement points" for Trendelenburg or "deep recline" positions only.

1. Lock Casters (page 6). Remove cable from Operator and loosen 11/16" hex nut on top of Operator. **(FIG.1)**
2. Have a second person hold the Back of chair steady and remove the Bow-Tie Cotter Pin and Clevis Pin. **(FIG.2)**
The Operator can now be rotated on threaded end of Gas Spring.
3. If Back of chair does not go into Trendelenburg by squeezing handle; Rotate Operator as shown, one (1) full revolution. **(FIG. 3A)**
If Back of chair goes into Trendelenburg WITHOUT squeezing handle; Rotate Operator as shown one (1) full revolution. **(FIG. 3B)**
4. Once you make an adjustment; Replace Clevis Pin and Bow-Tie Cotter Pin. Squeeze release handle and recline the back, to check for proper adjustment. Repeat above steps as needed until correct release action is achieved. TIGHTEN HEX NUT (that was loosened in step 1) once Operator is adjusted properly.



FIG. 1

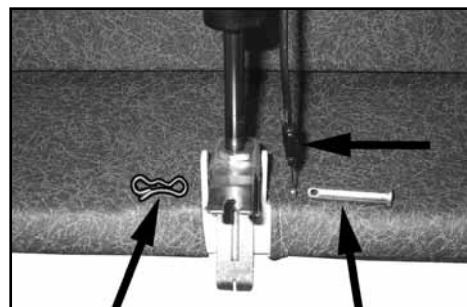

FIG. 2



FIG. 3

ADJUSTING RECLINER MECHANISMS

1. Place chair on its side in the 2nd recline position. Each chair has a L/R recline mechanism with two (2) tension adjustments on each - Four (4) total. Tension adjustment **A** controls the footrest and legrest action. Tension adjustment **B** controls the recline action from the 2nd to 3rd recline positions **(FIG. 4)**
2. Locate the two hex nuts (**A** or **B**) on the L&R recline mechanisms. Use a 7/16" wrench and adjust both L&R hex nuts one full revolution. R to tighten or L to loosen. **(FIG. 5)**
3. Return recliner to upright position and check recliner for reclining or legrest / footrest action. Repeat step two if needed. Tighten hex nuts no more than two full revolutions.

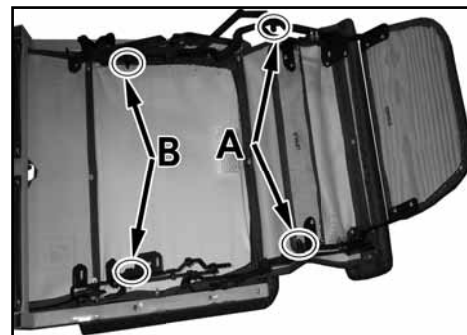

FIG. 4

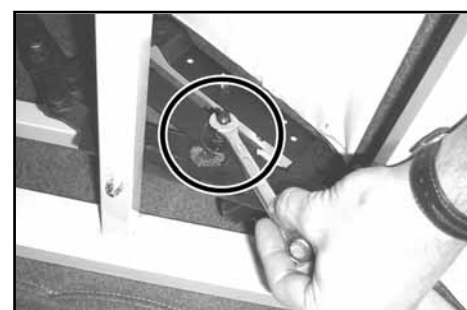

FIG. 5



GENERAL MAINTENANCE (cont'd)

REPLACING RECLINING MECHANISM

1. Remove Care Cliner back and put aside.
(see *Back Assembly Instructions page 4*)
2. Position recliner so that the recline mechanism, located on the chair frame, is accessible. Remove the 4 bolts that attach the recline mechanism to the chair frame.
(FIG 1)
3. Remove the recline mechanism, and the attached Seat Frame assembly from the chair Main Frame. Turn the Seat Frame & mechanism assembly upside down on a table or other stable surface.
(FIG 2)
4. Remove all screws that attach Footrest, Mid-Ottoman, Legrest, and Seat from the damaged recline mechanism.
(FIG 3)
5. Re-attach the Seat, Legrest, Mid-Ottoman, and Footrest to the new mechanism. Re-assemble the Seat/Recline Mechanism Assembly to the chair frame using (4) new locknuts and the bolts that were previously removed.
(FIG 1)

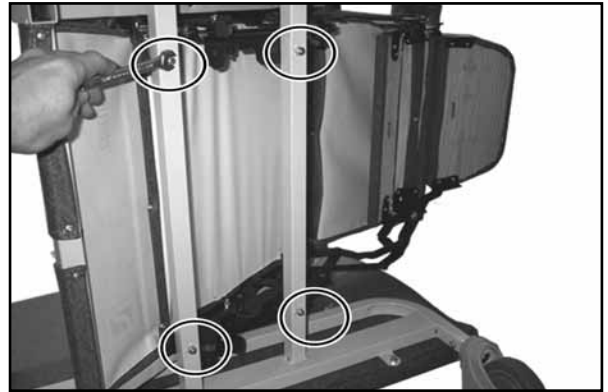

FIG. 1



FIG. 2

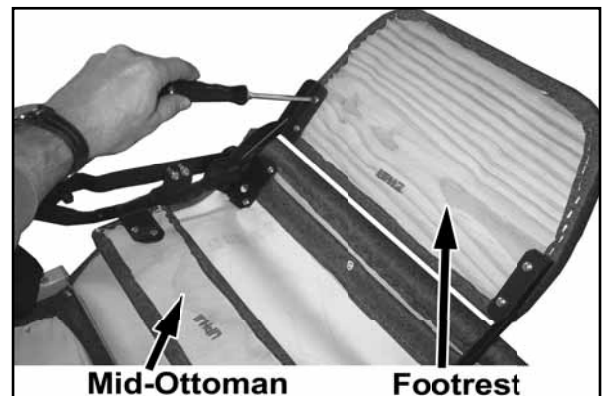

FIG. 3

GENERAL CARE & CLEANING

Remove hair & body oils; Your recliner should be cleaned with mild soap & water solution and a damp cloth on a regular basis (especially where skin & hair make contact with upholstery). Avoid harsh detergents or chemicals that could damage the upholstery or finish of your recliner. If the recliner is disinfected, the chair MUST be wiped off with ONLY clean water on a damp cloth.

Note: Disinfectants alone, will not provide adequate "grease or oil cutting" properties to remove hair & skin oils. Over time, the appearance and feel of your upholstery may diminish if not cleaned properly.

Please refer to the **PERMABLOK** instruction tag that is attached to your Care Cliner for complete care and cleaning instructions.

Retain information on tag for future use.

FOR FURTHER CLEANING INFORMATION VISIT:

<http://www.wincomfg.com/permablok-info-and-cleaning-instructions>



IMPORTANT !

REGULARLY lubricate pivot points on the Recline Mechanism with a silicone based lubricant.

Once per week, position the Chair Back into full recline position, squeeze release handle and go to full Trendelenburg position. This will keep the gas cylinder lubricated.

Periodically recheck tightness of all screws, bolts and nuts.

PARTS LIST GUIDE / SPECIFICATIONS

6530-6531 CARE CLINER

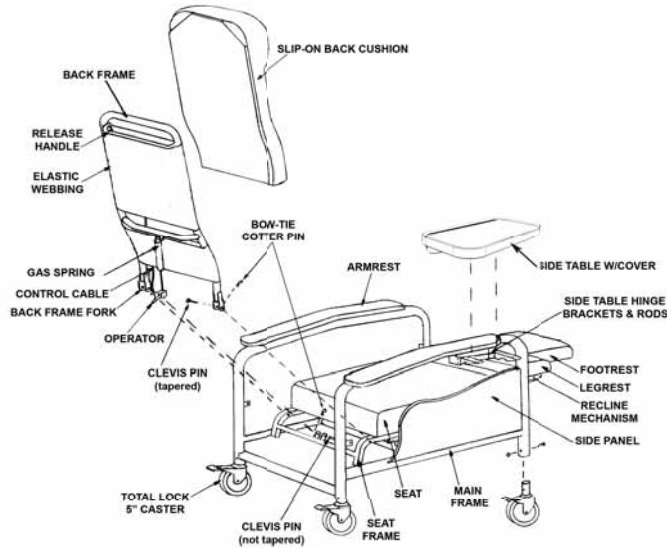

Seat Height	21"	Overall Width	32.25"
Seat Width.....	21"	Back Height Above Seat.....	31.5"
Back Width	21"	Seat Depth.....	20"
Overall Height	49"	Weight	94 lbs.

**See Chair for Maximum Weight Capacity*

6540-6541 XL CARE CLINER

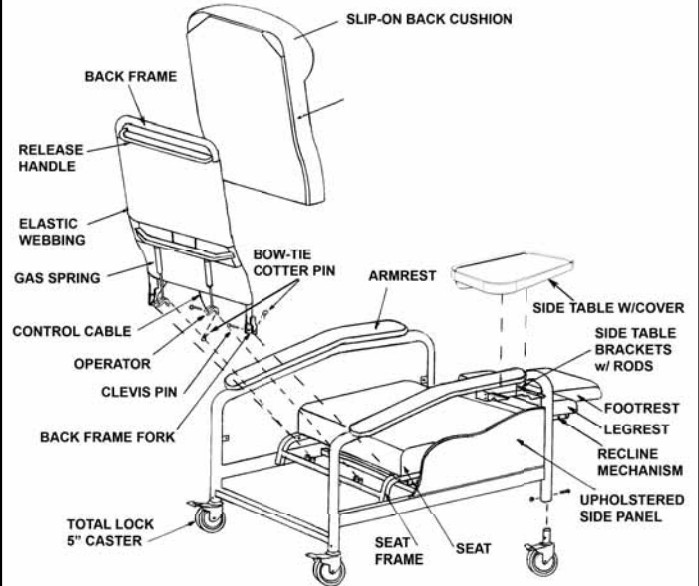

Seat Height	21"	Overall Width.....	36.25"
Seat Width	25"	Back Height Above Seat.....	31.5"
Back Width	25"	Seat Depth.....	20"
Overall Height	49"	Weight	111 lbs.

**See Chair for Maximum Weight Capacity*

6700-6704, 6710-6714 PREMIER CARE CLINER

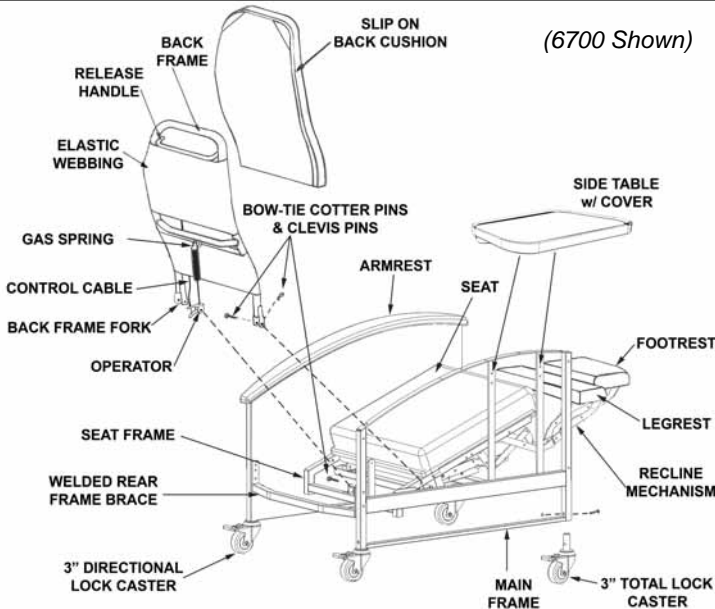

Seat Height	20.5"	Overall Width	670#=32"
Seat Width.....	670#=22" 671#=26"		671#=36"
Back Width	670#=22" 671#=26"	Back Height Above Seat.....	29.5"
Overall Height	47"	Seat Depth.....	19.5"
		Weight 670#=95 lbs. 671#=122 lbs.	

**See Chair for Maximum Weight Capacity*

6740, 6750 SWING-ARM PREMIER CARE CLINER

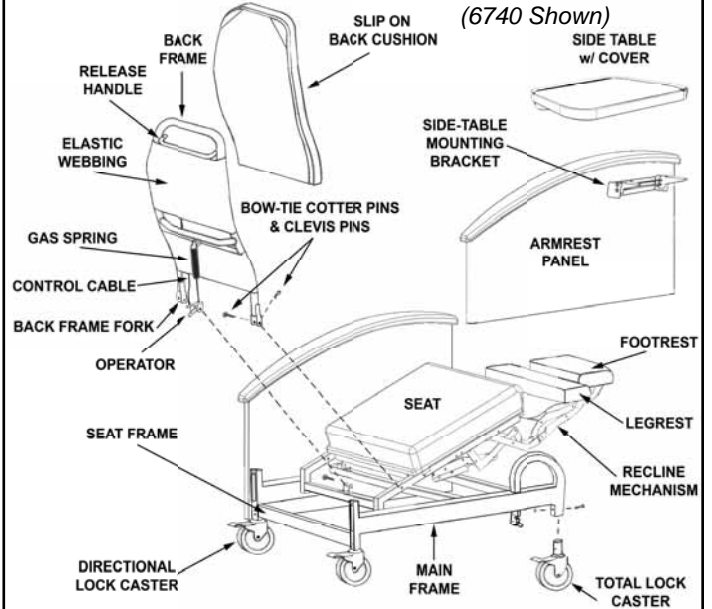

Seat Height	21"	Back Height Above Seat.....	6740=30"
Seat Width.....	6740=24" 6750=28"		6750=32"
Overall Height	46.5"	Seat Depth.....	21.5"
Overall Width.....	6740=34"	Weight 6740=125lbs. 6750=135lbs.	6750=38"

**See Chair for Maximum Weight Capacity*

NOTE: Gas Spring

6530-1/6550-1/670#/6740/6900/6940 = 1 Gas Spring.

6540-1/6570-1/671#/6750/6910/6950 (XL) = 2 Gas Springs.

PARTS LIST GUIDE / SPECIFICATIONS

6550-6551 DROP-ARM CARE CLINER

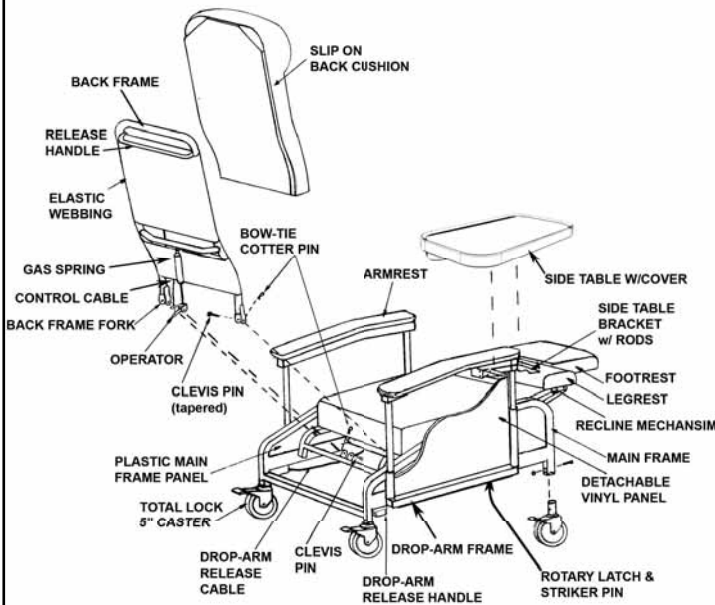

Seat Height	21"	Back Height Above Seat.....	31.5"
Seat Width.....	21"	Seat Depth.....	20"
Back Width	21"	Drop Arm Height To Floor.....	21"
Overall Height	49"	Weight	105 lbs.
Overall Width	33.75"		

***See Chair for Maximum Weight Capacity**

6570-6571 XL DROP-ARM CARE CLINER

(6940 Shown)

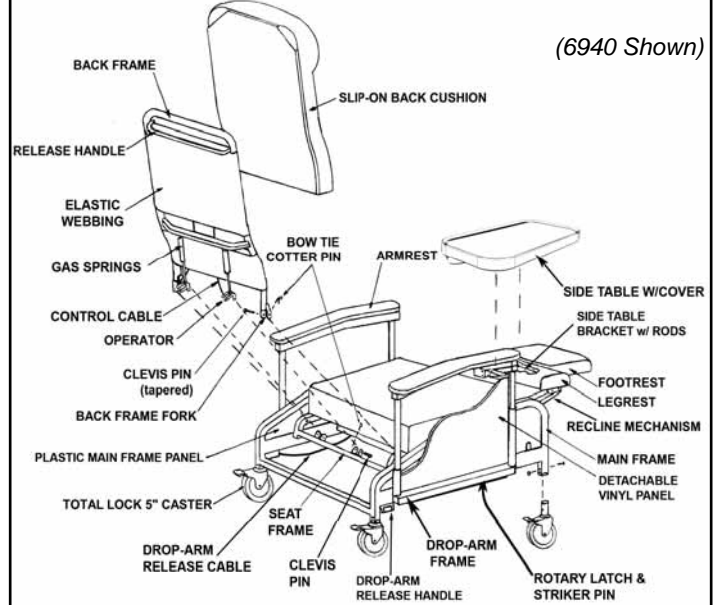

Seat Height	21"	Back Height Above Seat.....	31.5"
Seat Width.....	25"	Seat Depth.....	20"
Back Width	25"	Drop Arm Height To Floor.....	21"
Overall Height	49"	Weight	111 lbs.
Overall Width	37.75"		

***See Chair for Maximum Weight Capacity**

6900-6910 ELITE CARE CLINER

(6900 Shown)

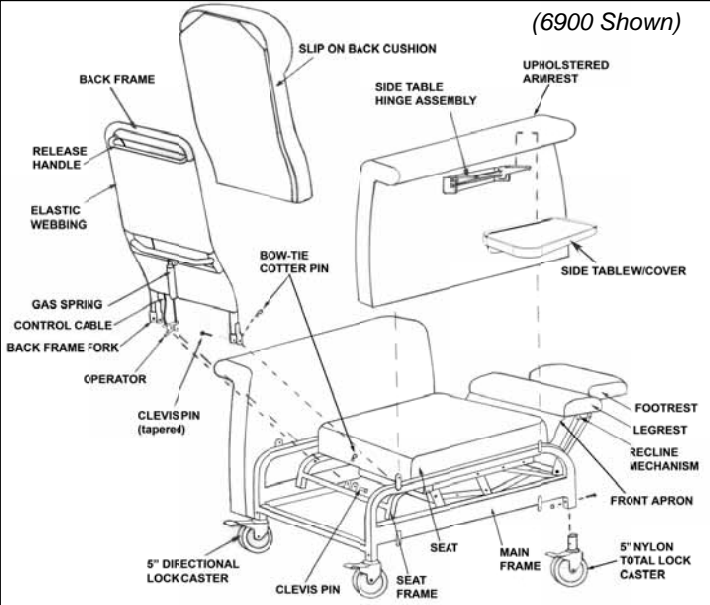

Seat Height	21"	Overall Width.....	6900=33.5"
Seat Width	6900=21" 6910=25"		6910=37.5"
Back Width	6900=21" 6910=25"	Back Height Above Seat.....	32.5"
Overall Height	48.5"	Seat Depth.....	20"
		Weight	6900=100 lbs. 6910=123 lbs.

***See Chair for Maximum Weight Capacity**

6940-6950 SWING-ARM CARE CLINER

(6940 Shown)

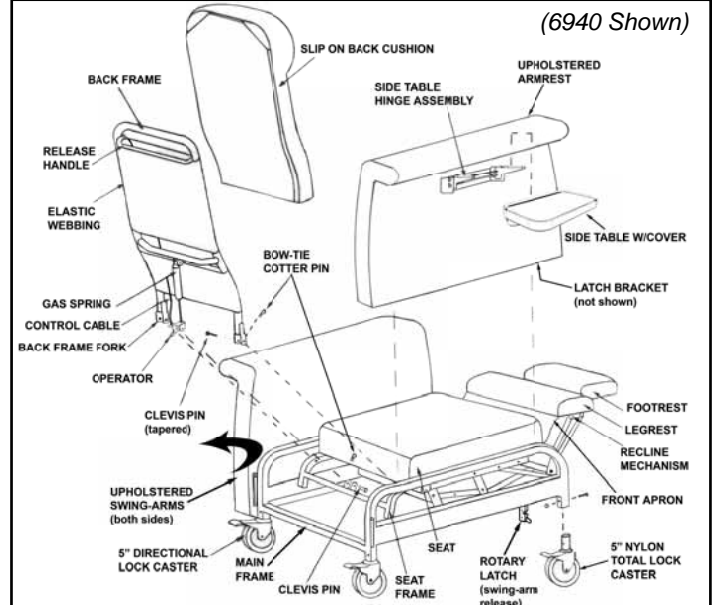

Seat Height	21"	Overall Width	6940=33.5"
Seat Width	6940=21" 6950=25"		6950=37.5"
Back Width	6940=21" 6950=25"	Back Height Above Seat.....	32.5"
Overall Height	48.5"	Seat Depth.....	20"
		Weight	6940=104lbs. 6950=127lbs.

***See Chair for Maximum Weight Capacity**

***NOTE: Weight Capacities**

ALWAYS refer to the weight capacity label on your chair. In all cases the labeling on the chair at the time of delivery is the correct rating for your chair and that weight rating should not be exceeded.

HEAT & MASSAGE OPERATING INSTRUCTIONS

HEAT & MASSAGE OPTIONS

Control is located on the inside of right arm of chair.

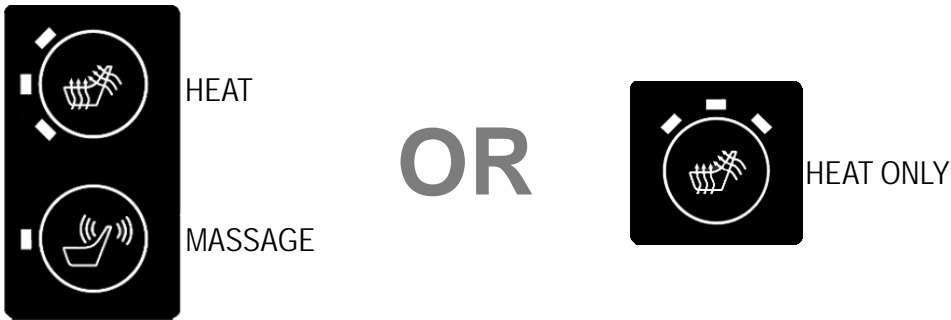

Heating: Push HEAT button - See indicator light on switch

3 Lights = High Heat

2 Lights = Medium Heat

1 Lights = Low Heat

No Light = HEAT OFF

Allow 5-8 minutes for back and seat to warm to desired TEMP. setting.

Heat will automatically shut off after approximately 60 minutes. *(Timer resets when switch is pressed)*

Massage (optional): Push MASSAGE button

1X = Lower Back / Low Intensity

2X = Lower Back / High Intensity

3X = Upper & Lower Back / Low Intensity

4X = Upper & Lower Back / High Intensity

5X = Alternating Upper & Lower Back / High Intensity

6X = MASSAGE OFF

Massage will automatically shut off after approximately 15 minutes. *(Timer resets when switch is pressed)*

- Use a DAMP CLOTH ONLY to clean switch, wiring or power pack (located under seat frame).
- If there is no heat or massage or flashing light on switch - check power cord connections to wall outlet AND connection of power cord to power pack unit under chair.
- If switch displays a flashing light; Check all accessible wire connectors under chair for possible loose connections, then contact Winco customer service: 1-800-237-3377.



FIG. 1

CORD STORAGE

(Models with Heat or Massage only)

1. Before transporting chair, or when heat & massage is not in use, power cord should be coiled and stored in the "Hook & Loop" fastener provided as shown, to prevent tripping on cord, damage to cord, damage to recliner, etc... **(FIG. 1)**

OPTIONS FOR YOUR WINCO CARE CLINER

Heat & Massage

HMHeat & Massage
 HTHeat ONLY

AVAILABLE FOR ALL MODELS

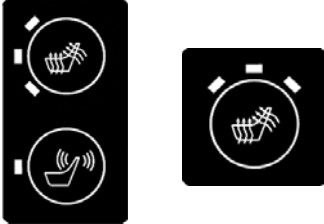

IV Pole & Attachment

IV..... IV Pole & Attachment
 AVAILABLE FOR ALL MODELS

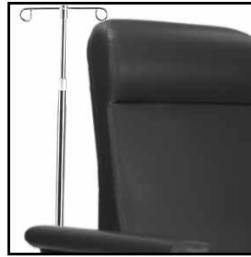

Leg Extensions

Leg Extensions raises chair 3"

RE00.....Round Leg Extension
 SE00.....Square Leg Extension
 RE00 for models.....653#, 654#
 SE00 for models.....655#,657#,6900,6910,6940,6950

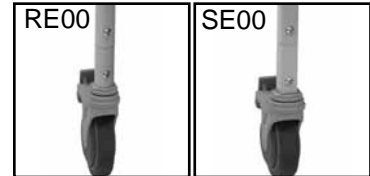

Pivot-table

Available on LEFT or RIGHT side
 FOR: 670#,671#,6740,6750,6900,6910,6940,6950



Oxygen Tank Holder

O2.....Oxygen Tank Holder
 ONLY AVAILABLE FOR
 670#,671#,6740,6750, 6900,6910,6940,6950



Side Cushion

SC00.....Side Cushion
 AVAILABLE FOR ALL MODELS

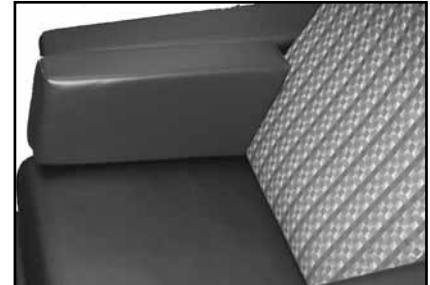

Armrest Covers

AC00.....Armrest Covers (Pair)
 ONLY AVAILABLE FOR 6900,6910,6940,6950

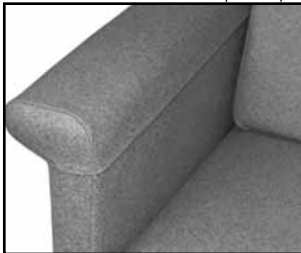

Foley Bag Hook

Available on LEFT or RIGHT side
 FOR: 670x,671x,6740,6750,6900,6910,6940,6950



LIMITED WARRANTY

TERMS

Winco Mfg., LLC. warrants this product to be free of manufacturer's defects in material and workmanship, provided that the product is used according to normal operating conditions and proper maintenance intended by manufacturer. This warranty is available only to the original retail purchaser, is non-transferable and commences on the date of retail sale; proof of purchase required.

LIMITED ONE YEAR COMPLETE PRODUCT WARRANTY: Winco Mfg., LLC warrants the complete product for one (1) year.

At Winco Mfg., LLC. sole discretion, it may repair or replace any components freight free that are found to be defective during the first year. Winco Mfg., LLC. shall not be liable for any labor, or any other costs incurred as a result of or in conjunction with a warranty claim.

LIMITED THREE YEAR WARRANTY: Winco Mfg., LLC warrants recliner mechanisms, electrical components, vinyl panels and Vinyl on upholstered parts [from cracking or delaminating] pressurized gas springs, and casters, when new, for a period of three (3) years. At Winco Mfg., LLC.'s Sole discretion, it may repair or replace components found to be defective. Winco Mfg., LLC. shall not be liable for any labor, shipping or any other costs incurred as a result of or in conjunction with a warranty claim.

LIMITED LIFETIME CHAIR FRAME WARRANTY: Winco Mfg., LLC warrants steel and aluminum base frames for all products, when new, for the lifetime of the original purchaser. This limited warranty does not apply to paint/finish or any components attached to the frame such as; upholstery, foam, casters, mechanisms or related parts that are covered under above warranties. Winco Mfg., LLC shall not be liable for any labor, shipping or any other costs incurred as a result of or in conjunction with a warranty claim.

The purchaser's exclusive remedy under this warranty shall be limited to such repair or replacement of defective components at Winco Mfg., LLC sole discretion. For warranty service, contact the dealer that the product was originally purchased from or Winco Mfg., LLC directly.

EXCLUSIONS

There are no other warranties, conditions, representations or guarantees, express or implied, made or intended by Winco Mfg., LLC and all other warranties, conditions, representations or guarantees including any warranties, conditions, representations or guarantees under any Sale of Good Act or Like legislation or statute is hereby expressly excluded. Any and all other implied warranties shall not extend beyond the duration of the express warranty. Liability for incidental or consequential damages is excluded to the extent permitted by law. Some states do not allow the exclusion or limitation so the above limitation or exclusion may not apply to you. This warranty gives you specific legal rights. In addition you may also have other rights, which vary from state to state.

GENERAL PROVISIONS

No warranty herein contained or set out shall apply when damage or repair is caused by any of the following:

1. Damage in transit.
2. Accident, alteration, abuse or misuse of product i.e. exceeding weight capacities, applying inordinate pressure to footrest/leg rest, use in Mental Health facilities like institutions or, any unintended use of the product or use in unintended environments (i.e. outdoor, showers, MRI rooms, etc..)
3. Fire, water damage, theft, war, riot, hostility, acts of God.

Examples contained in this list are not to be construed as all-inclusive.

Design, appearance, parts, & construction are subject to change without notice



ISO 9001-2008 CERTIFIED

