

JAE**CO** **Orthopedic**



Setup Instructions
for
WREX

JAECO WREX

Wilmington **R**obotic **EX**oskeleton

The JAE**CO** WREX is a functional upper limb orthosis designed to enhance movement for individuals with neuromuscular disabilities. Its state-of-the-art construction utilizes a light weight exoskeleton that approximates normal human anatomy. Linear elastic bands are used both for balance and to assist movement in three dimensions against the effects of gravity. These features provide for exceptional range of motion to aid in a variety of therapeutic and daily living activities.

This manual is designed to assist with initial set-up and balance of the WREX Mobile Arm Support

The WREX was developed with an NIH grant.

Special thanks to Tariq Rahman; PhD. Senior Research Engineer and Head (302) 651-6831 and Whitney Sample; Research Design Engineer (302) 651-6868, Pediatric Engineering Research Lab Department of Bio Medical Research A.I. duPont Hospital for Children, Wilmington, DE 19899 and in cooperation with Timothy Estilow; OTR/L and Deborah Humpl OTR/L,ATP Department of Occupational Therapy of Children's Hospital of Philadelphia.

Table of Contents

Section 1: Parts Description

- 1-1: Mount Parts Description
- 1-2: Arm Part Description

Section 2: Mount Attachment

- 2-1: Mount Base Attachment
- 2-2: Mount Link Attachment
- 2-3: MR-10 Mount Base Attachment
 - 2-3: Preparing Mount Base
 - 2-4: Mount Base Attachment
- 2-6: MR-8 Mount Base Attachment
 - 2-6: Preparing Mount Base
 - 2-7: Mount Base Attachment
 - 2-8: Optional Side Attachment
- 2-9: MR-7 Mount Base Attachment
 - 2-10: Preparing Backrest and Mount Base
 - 2-11: Mount Base Attachment
 - 2-13: Rotating Mount Arms

Section 3: WREX Arm Setup

- 3-1: Measuring and Presetting Arm Components
- 3-1: Select and Pre-fit Forearm Support
- 3-2: Attach Forearm Support to WREX Arm
- 3-3: Measure and Preset Humeral Elevating Links

Section 4: Fitting and Adjustments with Client

- 4-1: Attaching the WREX Arm to the Wheelchair Mount
 - 4-1: WREX Arm Attachment
- 4-2: Position WREX Shoulder Joint
 - 4-2: Pitch Pivot Adjustment
 - 4-3: Roll Pivot Adjustment
- 4-4: Place the Clients Arm into the WREX
- 4-4: Check for Appropriate Alignment
- 4-5: Application of Elastic Bands
- 4-6: Basic Adjustment for Functionality
- 4-7: Desired Functional Outcomes of the WREX
- 4-7: Removing the Arm from the WREX
- 4-8: Finalizing Setup

Section 1

Part Description

JAECO WREX

Mount Parts Description

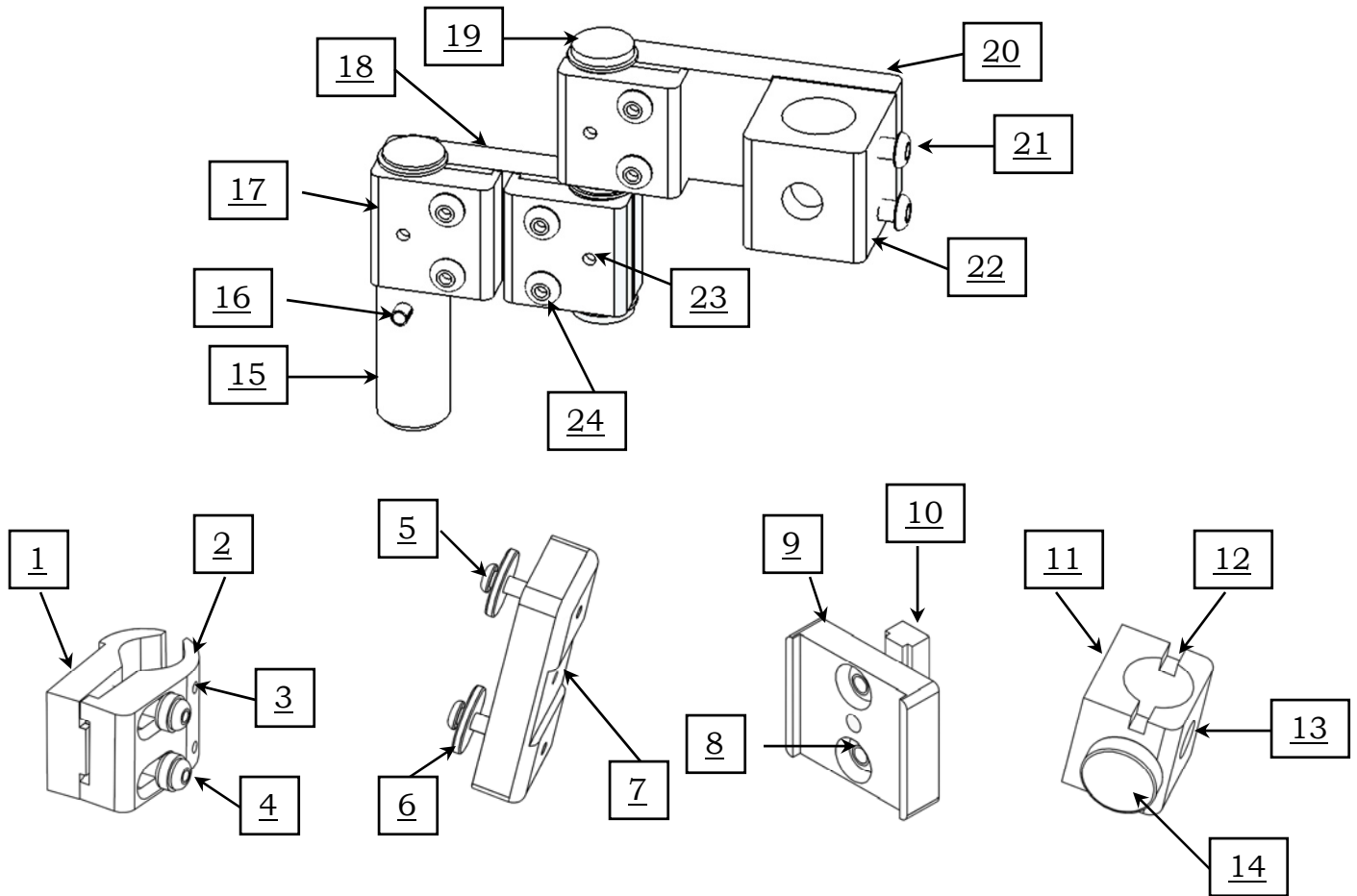

1	MR-10 Mount Adapter	13	Attachment Hole
2	Moveable Jaw	14	Locking Knob
3	Jaw Locking Set Screw	15	Arm Mount Shaft
4	Base Clamp screw	16	Alignment Pin
5	Mount Screw	17	Arm Clamp
6	Reinforcement Washer	18	3 inch Arm
7	MR-7 Mount Adapter	19	Joint Pin
8	T-Nut Screws	20	4 inch Mount Arm
9	MR-8 Mount Adapter	21	Shaft Screw
10	Mr-8 T-nut	22	Shaft Mount Base
11	Arm Mount Base	23	Clamp Locking Set Screw
12	Alignment Slot	24	Arm Clamp Screw

JAECO WREX

Arm Parts Description

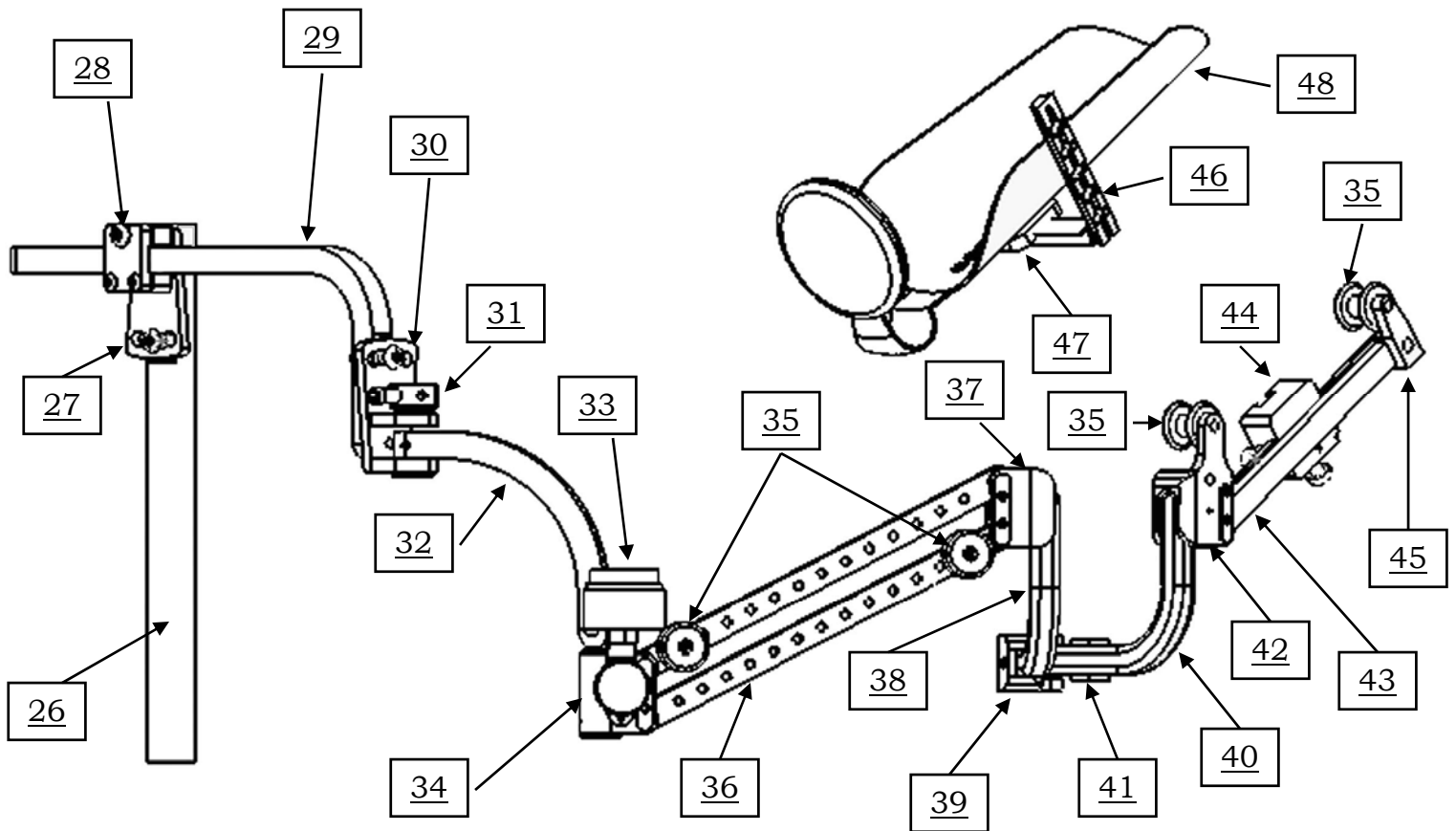

26	Pitch Mount Shaft	38	Elevator J-Link
27	Pitch Pivot	39	Elbow Pivot
28	Pitch Pivot Cover	40	Elbow J-Link
29	Pitch Link	41	Band Cradle
30	Roll Pivot	42	Forearm Pivot
31	Lateral Stop	43	Forearm Link
32	Shoulder Link	44	Slide Saddle
33	WREX Level	45	Band Spool Pivot
34	Upper Humeral Pivot	46	L-Bar
35	Band Spool	47	Forearm Support Mount Plate
36	Humeral Links	48	Forearm Support
37	Lower Humeral Pivot		

Section 2

Mount Attachment

Mount Base Attachment

The WREX can be attached to most common wheelchairs and mobility seating systems utilizing one of the three Mount Bases provided with the arm. These are the same attachment systems that are the basis of our *JAECO* Mount Relocator.

It is essential that you identify the best attachment position. Then choose from one of the three mount bases for either;

(1) a Tubular Mount: MR-10

(2) a Keyed Back Post: MR-8

(3) direct attachment to a Molded Backrest: MR-7

MR-10



MR-8



MR-7

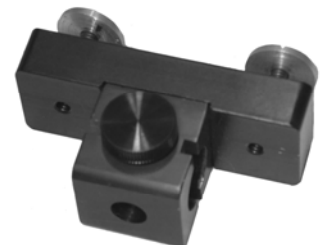

Mount Link Attachment

The Mount Link for the WREX is designed so that each of the three articulation; at the Mount Base, at the Link Joint and at the Pitch Mount Shaft can pivot 360 degrees. This will allow for the ability to locate the Pitch Mount Shaft in a large variety of locations to optimize its position and/or avoid other apparatus attached to the chair.

The Mount Links will be shipped with the Clamp Screws and Clamp Locking Set Screws loosened for ease of application.

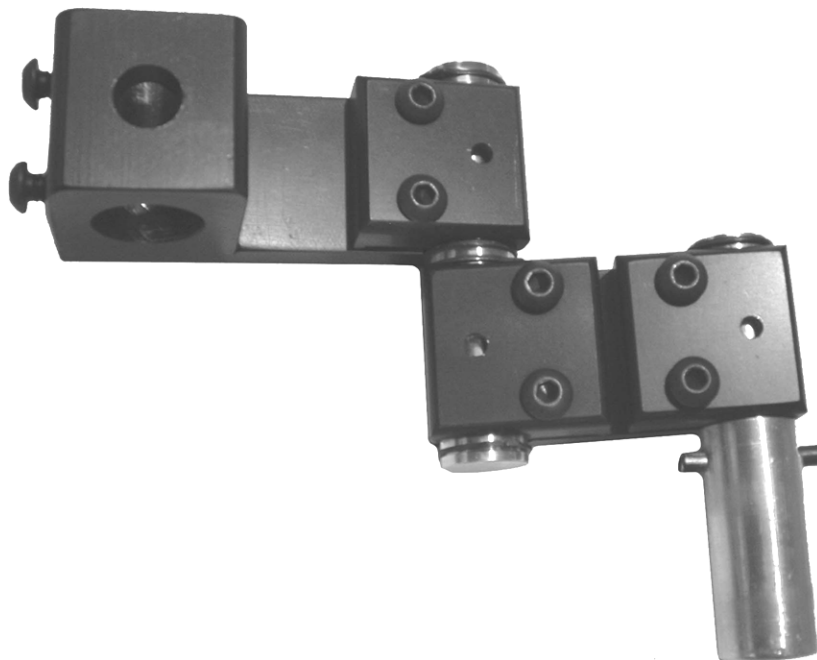

MR-10 Mount Base Installation

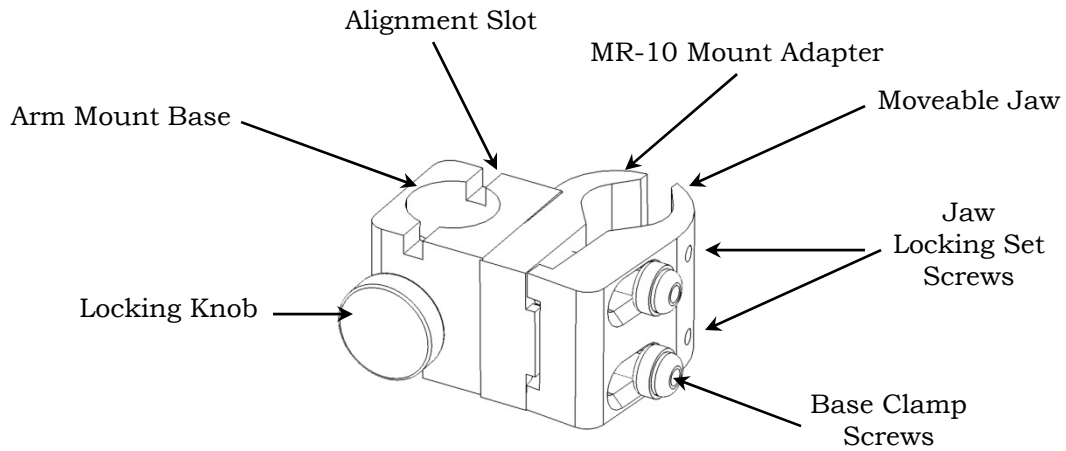

Preparing Mount Base

1. Orient the Arm Mount Base as in illustration above. Insert the Mount Base Screw (supplied with Arm Mount Base) thru the Attachment Hole to the MR-10 Mount Adapter. Using large T-Wrench secure these two parts.



2. Loosen Clamp Screws using large T-Wrench **Do not remove screws** and open clamp to its widest position by pushing the Moveable Jaw forward and pulling it outward as shown in photo.

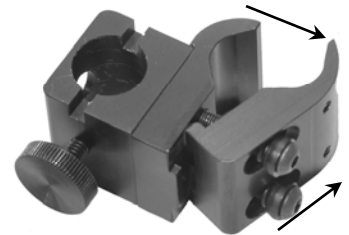

Mount Base Attachment

1. In this open position, apply the mount to the wheelchair upright (back post).

Note: *Mount positioning (angle) will vary depending on wheelchair style.*

2. Position the mount so that the top of the mount is not more than 6 inches below the top of the clients shoulder.

3. Tighten Base Clamp Screws.

Do not tighten Jaw Locking Set Screws at this time.

Note: *Adjustments in position may be necessary for optimal function.*

4. Loosen but **do not remove** the Locking Knob on the Arm Mount Base.
5. Position the Mount Link so that the Alignment Pin in the Arm Mount Shaft is aligned with the Alignment Slot of the Arm Mount Base. Insert the shaft into the base and tighten the Locking Knob.

6. Preposition the Mount Links so that the Shaft Mount Base that receives the Pitch Mount Shaft is located in the lateral 1/3 of the clients torso on the side which you intend to use the WREX Arm.

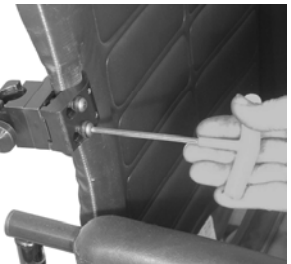

7. Snug but do not tighten the **six** Clamp Screws using the large T-Wrench. *Add enough tension so that the joints do not move easily but can be repositioned if required to optimize the arm alignment.*

Note: *Do not tighten the Clamp Locking Set Screws at this time.*



8. Hold the Pitch Mount Shaft so that the black Pitch Pivot is at the proximal end, the hole through the Pitch Pivot is in the line of progression of the chair and the plate of the pivot is facing laterally. Insert the Pitch Mount Shaft into the Shaft Mount Base. Snug but do not tighten the Shaft Screws on the Shaft Mount Base.



9. With client sitting in the chair align the square hole in the Pitch Pivot approximately 1 ½ inches above their shoulder.



MR-8 Mount Base Installation

For use on some Invacare and Motion Concept Seating Systems

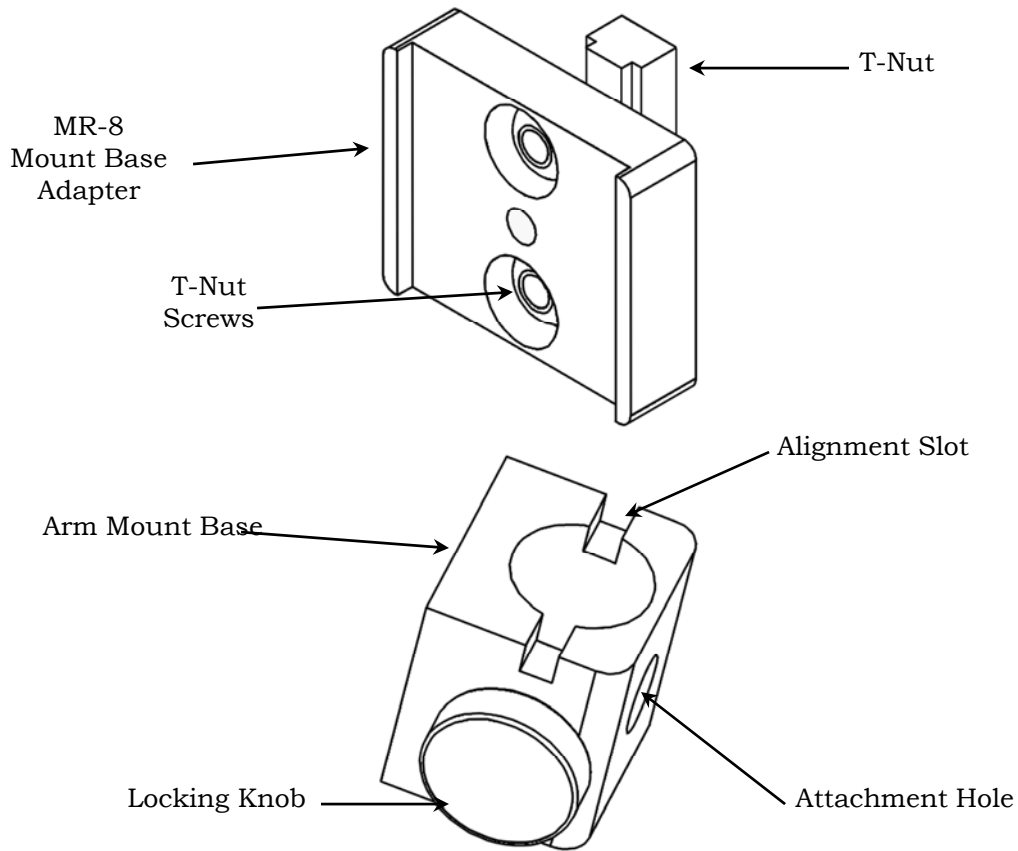

Preparing Mount Base

1. Locate and mark an area 2 to 8 inches below the clients shoulder on the Keyed Back Post of the wheelchair.
2. Locate and remove (if applicable) the plastic cap from the top of the Keyed Back Post of the wheelchair.



Keyed
Back Post

Note: *Adjustments in position may be necessary for optimal function.*

Mount Base Attachment

1. Using the large T-Wrench loosen, **Do not remove**, the two T-Nut Screws on the MR-8 Mount Adapter.
2. Insert the T-Nut into Keyed Back Post channel and position the MR-8 Mount Adapter at the marked location (see Preparing Mount Base #1). Tighten the two T-Nut screws.

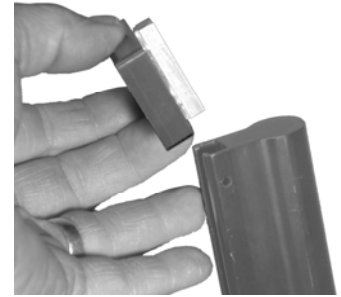

Note: *It may be necessary to remove the Spreader Bar (bar that links both Keyed Back Posts) to attach the Mount Adapter below and sometimes above the marked location. Loosen, **Do not remove**, all four Spreader Bar bolts using 7/16 inch wrench and slide bar out of Keyed Back Posts.*



3. Orient the Arm Mount Base as shown in illustration. Insert the Mount Base Screw (supplied with Arm Mount Base) thru the Attachment Hole to the MR-8 Mount Adapter. Using the large T-Wrench secure these two parts.



Note: *If Spreader Bar was removed, reattach Spreader bar, secure in place, and insert the plastic cap that was removed in step 4 of Preparation instructions Page 2-4.*

Note: *Adjustments in position may be necessary for optimal function.*

4. Loosen but **do not remove** the Locking Knob on the Arm Mount Base.
5. Position the Mount Link so that the Alignment Pin in the Arm Mount Shaft is aligned with the Alignment Slot of the Arm Mount Base. Insert the shaft into the base and tighten the Locking Knob.

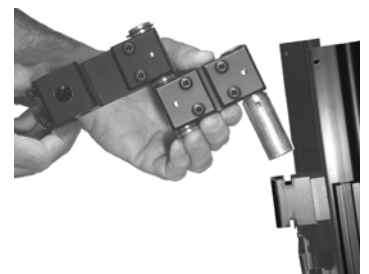

Optional Side Attachment

1. Using the large T-Wrench loosen, **Do not remove**, the two T-Nut Screws on the Mount Adapter.

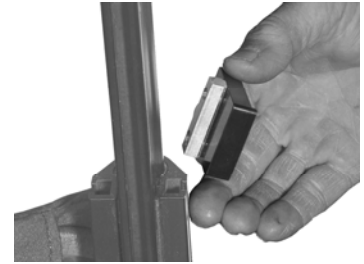

2. Insert the T-Nut into Keyed Back Post channel and position the MR-8 Mount Adapter at the marked location (see Preparing Mount Base #1). Tighten the two T-Nut screws.



3. Orient the Arm Mount Base as shown in illustration. Insert the Mount Base Screw (supplied with Arm Mount Base) thru the Attachment Hole to the MR-8 Mount Adapter. Using the large T-Wrench secure these two parts.



Note: *Adjustments in position may be necessary for optimal function.*

4. Loosen but **do not remove** the Locking Knob on the Arm Mount Base.
5. Position the Mount Link so that the Alignment Pin in the Arm Mount Shaft is aligned with the Alignment Slot of the Arm Mount Base. Insert the shaft into the base and tighten the Locking Knob.

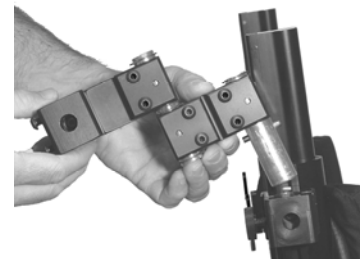

6. Preposition the Mount Links so that the Mount Shaft Base that receives the Pitch Mount Shaft is located in the lateral 1/3 of the clients torso on the side which you intend to use the WREX Arm.

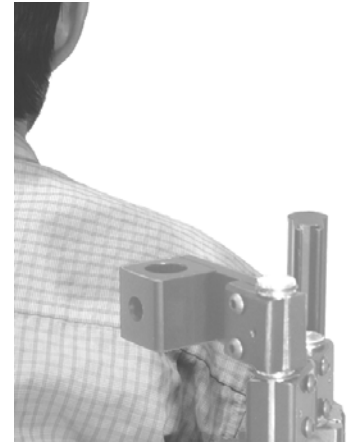

7. Snug but do not tighten the **six** Clamp Screws using the Large T-Wrench. *Add enough tension so that the joints do not move easily but can be repositioned if required to optimize the arm alignment.*

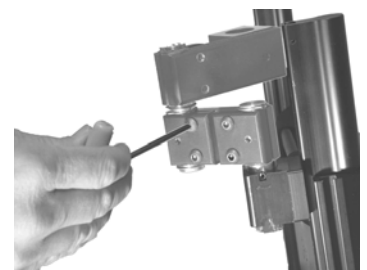

Note: *Do not tighten the Clamp Locking Set Screws at this time.*

8. Hold the Pitch Mount Shaft so that the black Pitch Pivot is at the proximal end, the hole through the Pitch Pivot is in the line of progression of the chair and the plate of the pivot is facing laterally. Insert the Pitch Mount Shaft into the Mount Shaft Base. Snug but do not tighten the Shaft Screws on the Mount Shaft Base.

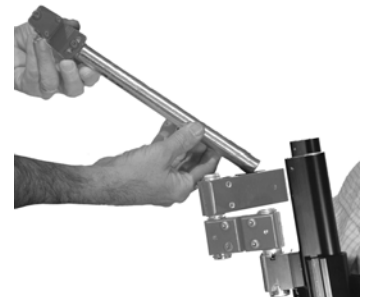

9. With client sitting in the chair align the square hole in the Pitch Pivot approximately 1 ½ inches above their shoulder.

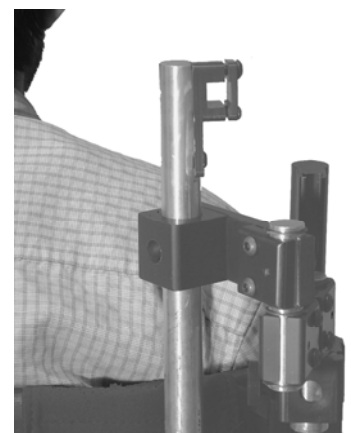

MR-7 Mount Base Installation

For use on some Permobil and Other Seating Systems

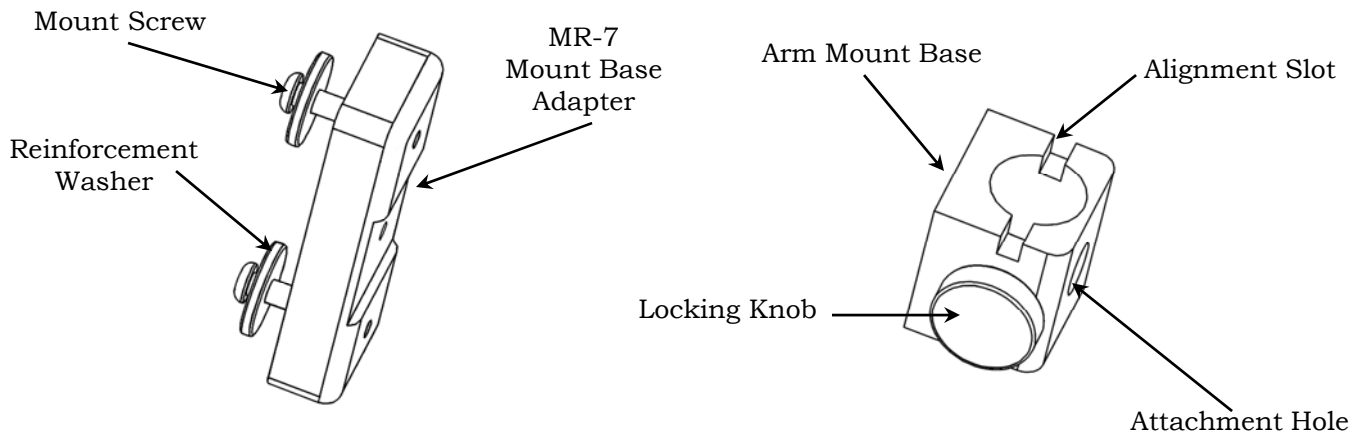

Preparing Backrest and Mount Base

1. Remove backrest cushion.
2. Tape the template on the back of the backrest 1 ½ to 2 inches down from upper edge and as close to the midline as possible.

Note: Place Base Drill Template on flattest area of backrest



4. Use drill bit supplied and drill the two marked holes.



5. Orient the Arm Mount Base as shown in illustration. Insert the Mount Base Screw (supplied with Arm Mount Base) thru the Attachment Hole to the MR-7 Mount Adapter. Using large T-Wrench secure these two parts.

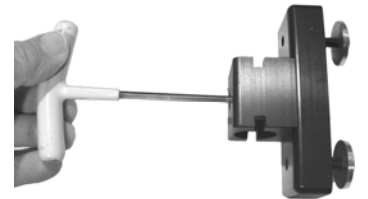

Mount Base Attachment

- Using the large T-Wrench remove the two Mount Screws with Reinforcement Washers from the MR-7 Mount Base. Insert the screws with Reinforcement Washers through the drilled holes and into the MR-7 Mount Base. Tighten the two Mount Screws



- Loosen but **do not remove** the Locking Knob on the Mount Base.



- Position the Mount Link so that the Alignment Pin in the Arm Mount Shaft is aligned with the Alignment Slot of the Arm Mount Base. Insert the shaft into the block and tighten the Locking Knob.

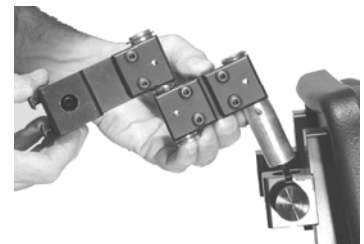

- Preposition the Mount Links so that the Mount Shaft Base that receives the Pitch Mount Shaft is located in the lateral 1/3 of the clients torso on the side which you intend to use the WREX Arm.



Note: Check to insure the Clamp Screws are accessible.
If they are not complete the steps on page 2-13.



10. Snug but do not tighten the **six** Clamp Screws using the Large T-Wrench. *Add enough tension so that the joints do not move easily but can be repositioned if required to optimize the arm alignment.*

Note: Do not tighten the Clamp Locking Set Screws at this time.

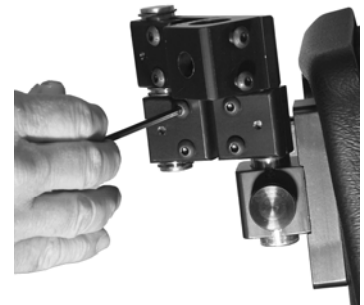

11. Hold the Pitch Mount Shaft so that the black Pitch Pivot is at the proximal end, the hole through the Pitch Pivot is in the line of progression of the chair and the plate of the pivot is facing laterally. Insert the Pitch Mount Shaft into the Mount Shaft Base. Snug but do not tighten the screws on the Mount Shaft Base.

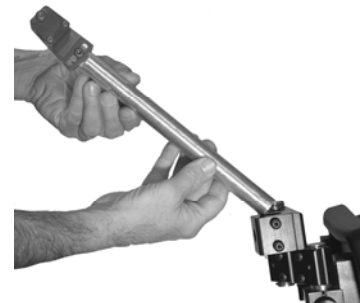

12. With client sitting in the chair align the square hole in the Pitch Pivot approximately 1 ½ inches above their shoulder.

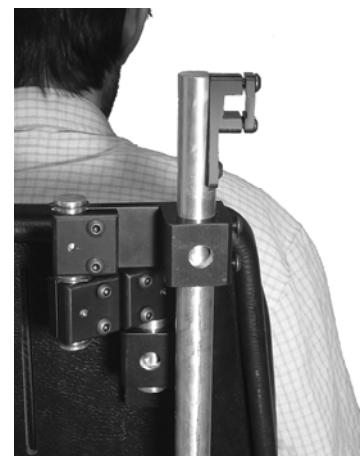

Rotating Mount Arms

1. Lay the Mount Arm flat on work surface.

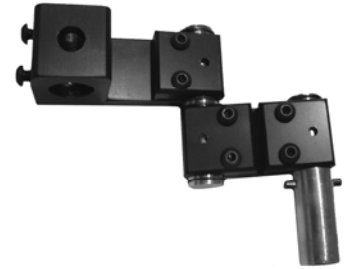

2. Using the large T-Wrench remove the two Clamp Screws and the Arm Clamp from the 4 inch Mount Arm.

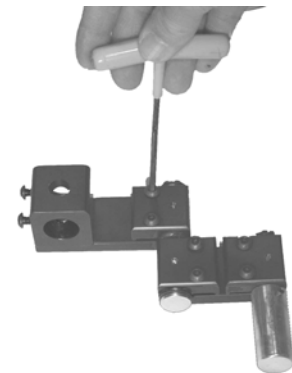

3. Rotate the 3 inch Arm and position the 4 inch Mount Arm onto the Joint Pin as shown. Replace the Arm Clamp and the two Clamp Screws. Tighten the Clamp Screws.

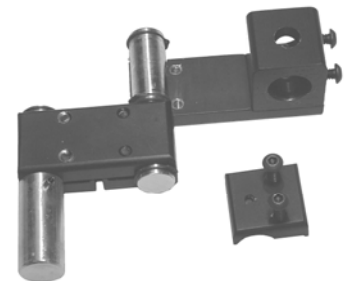

Note: The Clamp Screws on the 3 inch Arm and the 4 inch Mount Arm should be facing opposite directions as shown in photo.

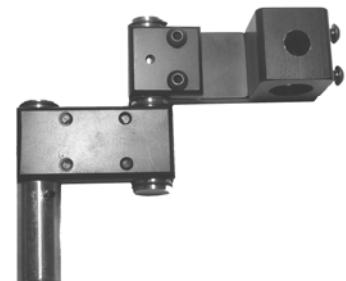

Section 3

WREX Arm Setup

Measuring and Presetting Arm Components

The WREX is designed for optimum functionality when all of its exoskeletal articulations can approximate the patients anatomical joints. Although this can not be exact, careful measurement and pre-fitting of the arm components will maximize the outcome.

We recommend fittings and assemblies in this section should not be done while the arm is attached to the wheelchair.

Select and Pre-fit Forearm Support

1. Measure the distance from the Olecranon to the Ulna Styloid then subtract one inch. Insure size and side is correct from the chart attached page 4-8.
2. Place the clients arm into the forearm support. When the clients arm is strapped in, the fit should be snug but not tight. The Forearm support circumference can be adjusted by squeezing the edges of the trough together. *This does require a great deal of force. Use of a vice or small rubber mallet may be required.* Alternately padding may be added to insure a intimate fit.
3. Remove the clients arm from the Forearm Support.



Attach Forearm Support to WREX Arm

1. While depressing the **button on the side** of the Forearm Support Slide Saddle.
2. Slide the L-Bar into the Slide Saddle from the top.
3. Release button on the Slide Saddle to lock the Forearm Support in the first (highest) position on the L-Bar.

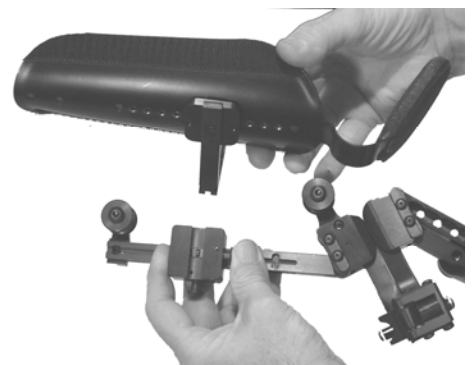

Measure and Preset Humeral Elevating Links

1. On the side you plan to fit the orthosis take a measurement from the head of the humerus to the lateral epicondyle. Record this measurement.



2. Lay the WREX arm flat on a work surface.



3. Using the medium T-Wrench remove the **Four** screws that connect the sections of the upper and lower Humeral Elevating Links

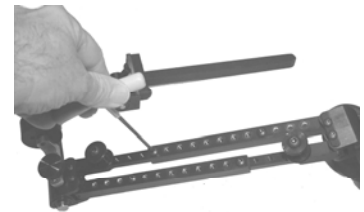

3. By sliding the link sections on each other shorten or lengthen the Humeral Links until the distance between the centers of the Upper and Lower Humeral Pivots is equal to the measurement from Step 1.

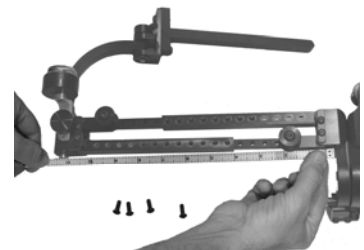

4. Reinsert and tighten the **Four** screws to secure both links.

Section

4

**Fitting and
Adjustments with
Client**

Attaching the WREX Arm to the Wheelchair Mount

Transfer the patient into the Wheelchair

WREX Arm Attachment

1. Using the large T-Wrench loosen but do not remove the **top screw** on the Pitch Plate Cover.



2. Orient the WREX arm with the slot in the Roll Pivot facing up.
3. Slide the Pitch Link into the square hole of the Pitch Pivot.



Note: *The WREX arm is designed to have as little friction as possible at all of its articulations. For client safety please be sure to control the entire device as you are attaching the arm and making adjustments.*



Position WREX Shoulder Joint

Pitch Pivot Adjustment

1. Using the large T-Wrench, while supporting the WREX arm, loosen the screw on the Pitch Pivot adjustor.



2. With the aid of the Bubble Level position the Pitch Link so that it is horizontal and parallel to the floor.
3. Tighten the Pitch Plate Adjuster Screw



4. Slide the Pitch Link into a position where the articulation of the Roll Pivot is in line with the top of the shoulder joint with a minimum of 1½ inches of space between the skin and the bottom of the pivot.



Note: *Positioning of the Shoulder Link may require loosening of the two screws on the Shaft Mount Base or repositioning the Mount Links*

Roll Pivot Adjustment

1. Using the large T-Wrench loosen the screw for the Roll Pivot Adjustment.

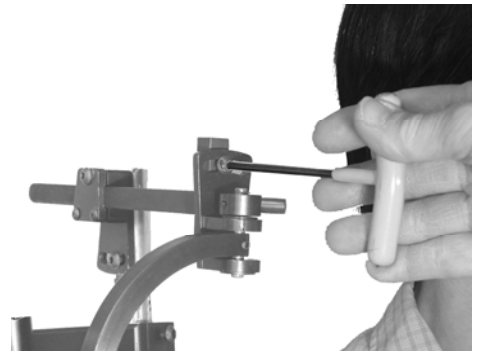

2. With the aid of the bubble level roll the adjustment medially or laterally until the bubble is centered.



3. Tighten the Roll Pivot Adjuster Screw.

4. Using the large T-Wrench tighten all six of the Mount Link Clamp Screws and the two Mount Shaft Base Screws.

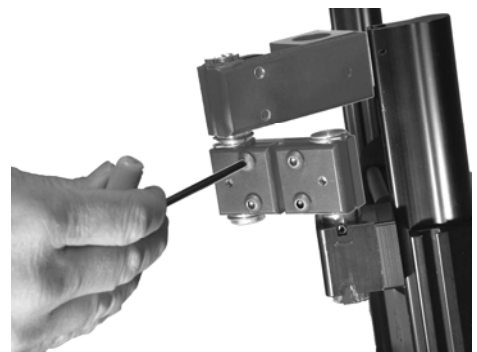

5. Recheck that the bubble in the level is still centered. Adjust the Pitch Pivot or Roll Pivot as necessary.

Caution: Do not put the clients arm into the orthosis until all previous steps in this section have been completed.

Place the Clients Arm into the WREX

Because the WREX operates with band tension it must carefully be handled during arm placement to prevent injury

1. With one hand support the WREX arm under the Forearm Support.
2. Using your other hand lift the clients arm with his/her elbow flexed and place it in the Forearm Support. Insure that the back of elbow is touching the elbow pad
3. Secure Velcro straps



Check for Appropriate Alignment

1. Roll Pivot joint should be 1½ inch above the top of the shoulder to allow full shoulder range of movement.
 1. *Adjust with the height of the Mount Shaft*
2. Upper Humeral Pivot should be aligned with the head of the humerus and the Lower Humeral Pivot should align with the lateral epicondyle.
 1. *Adjust by shortening or lengthening the Humeral Elevating Links*
3. Elevator Links should align with the shaft of the humerus
 1. *Adjust the height of the Roll Pivot above the shoulder*
4. Clients elbow should be above the center of the Elbow Pivot
 1. *Adjust depressing the **bottom button** on the forearm Slide Saddle and moving the forearm support forward or back.*

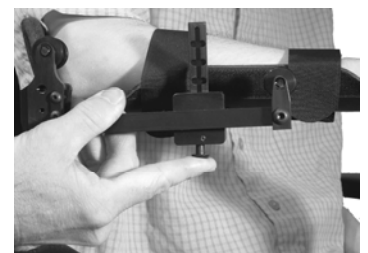

Note: *Insure there is clearance between the elbow area of the Forearm Support and the Elbow Pivot, when the clients arm is flexed.*

Application of Elastic Bands

The number of bands varies depending on the weight of the clients arm and their strength

The optimal number of bands allows for the client to move through their maximal range of movement. The client must be able to return to starting location to avoid the arm floating in space without control.

JAECO supplies three sizes of elastic bands:

Blue: Large

Red: Medium

Beige: Light

Note: Start with the largest bands then use the smaller bands to “fine tune” the clients movements.

1. Supporting the clients arm at the elbow with one hand, loop elastic bands one at a time over the Band Spools on the Humeral Elevating Links until the arm begins to “float” in space.



2. Supporting the clients forearm with one hand, loop elastic bands one at a time over the Band Spools on the Forearm Link until the client is able to easily flex and extend their elbow.

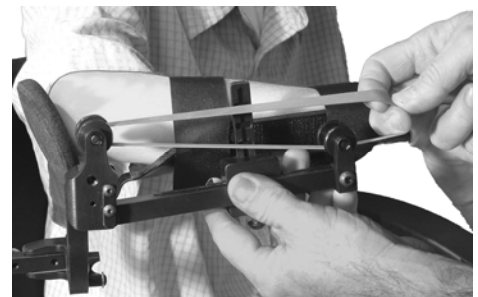

Basic Adjustment for Functionality

Ask the client to move horizontally from side to side then toward and away from the body across a tabletop.

To improve reach from side to side:

1. Support the clients limb
2. Loosen the Roll Adjustment screw
3. Rolling the arm toward the midline to aid in reaching medially. Rolling the arm away from midline will aid in reaching laterally.

To improve forward and return reach:

1. Support the clients limb
2. Loosen Pitch Adjustment screw
3. Tilting the Pitch Link down will aid in reaching away from the body. Tilting the Pitch Link up will aid in reaching toward the body.

Ask the client to move vertically from tabletop to mouth and from tabletop to face.

To improve humeral elevation or depression:

1. Support the clients limb
2. Add / remove elastic bands or decrease / increase the size of the bands

To improve Humeral rotation:

1. Add small elastic bands across the Elbow Pivot

To improve elbow flexion or extension

1. Support the clients forearm
2. Add / Remove elastic bands or decrease / increase the size of the bands



Note on adjustments:

- Mark or document the starting point before any adjustments are made so the system can be moved back if the adjustment is not effective.
- Make adjustments in small increments
- Only make one adjustment at a time (example: if the client is having trouble reaching across their body at and forward. Adjust one or the other to optimize that movement before working on the next)
- Give the client the opportunity to use the WREX multiple times before making major adjustments

Desired Functional Outcomes of the WREX

- Ability to access face for
 - Oral hygiene
 - Feeding
 - Washing face
 - Shaving
 - Wiping nose
 - Adjusting glasses
 - Etc.
- Ability to access environment for
 - Using computer
 - Handwriting
 - Retrieving items from countertop, closet, etc.

Removing the Arm from the WREX

Because the WREX operates with band tension it must carefully be handled during arm removal to prevent injury

- Secure Forearm support with one hand holding in place
- Remove velcro straps and clients arm with the other hand
- Allow the forearm and shoulder links to return to starting position in a slow and controlled manner



Finalizing Setup

Check Overall Setup

- Again, observe clients shoulder and forearm to be sure they are at a comfortable, level, resting position. (If the client is uncomfortable, WREX wear time and use will be limited.)
- Make adjustments as necessary to achieve functional use.

Secure the Settings

- Evaluate the WREX with a variety of activities. When you and the client are satisfied with the overall function, secure the settings.
- Insure all knobs are tight.
- Using the large T-Wrench insure all screws are tight.
- Using the small T-Wrench tighten the Jaw Locking Set Screws on the Mount Base (if applicable) and the Clamp Locking Set Screws on the Mount Arm. The pointed end of these locking set screws will pierce fabric and/or metal.

Warning: If Further adjustments are required to Mount Base or Mount Arm, loosen these locking set screws first.

Locking the MR-10 Mount Base in Place

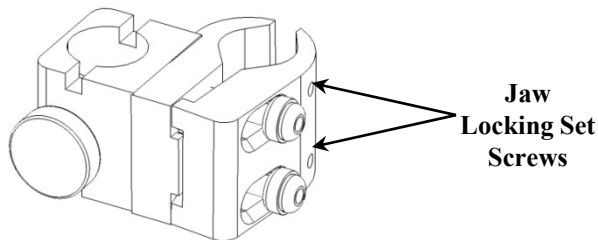

Locking the Mount Arm in Place

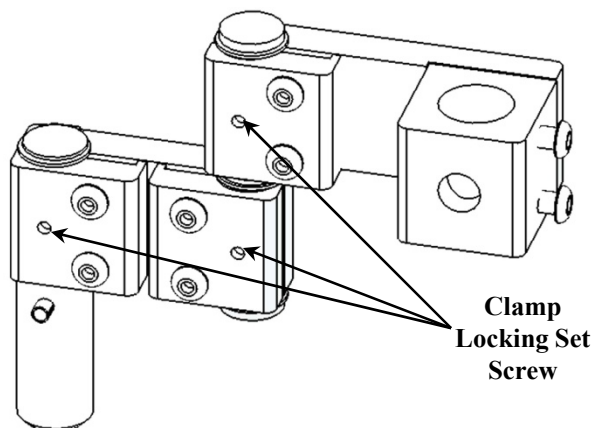

WREX Product Numbers

JWREX-1-L: WREX Arm left (Forearm Support sold Separately)

JWREX-1-R: WREX Arm right (Forearm Support sold Separately)

Forearm Support Size Chart

WFS-6: Ex.Small	Elbow to wrist crease length: Minimum - 6" Maximum - 7-1/2"
WFS-8: Small	Elbow to wrist crease length: Minimum - 8-1/2" Maximum - 9-1/2"
WFS-9: Medium	Elbow to wrist crease length: Minimum - 9-1/2" Maximum - 10-1/2"
WFS-10: Large	Elbow to wrist crease length: Minimum - 10-1/2" Maximum - 12"
WFS-11: Ex.Large	Elbow to wrist crease length: Minimum - 11-1/2" Maximum - 13"
WFS-1C: Custom	Supply: Elbow to Wrist Crease Length & Largest Circumference of Forearm