

SPIRIT

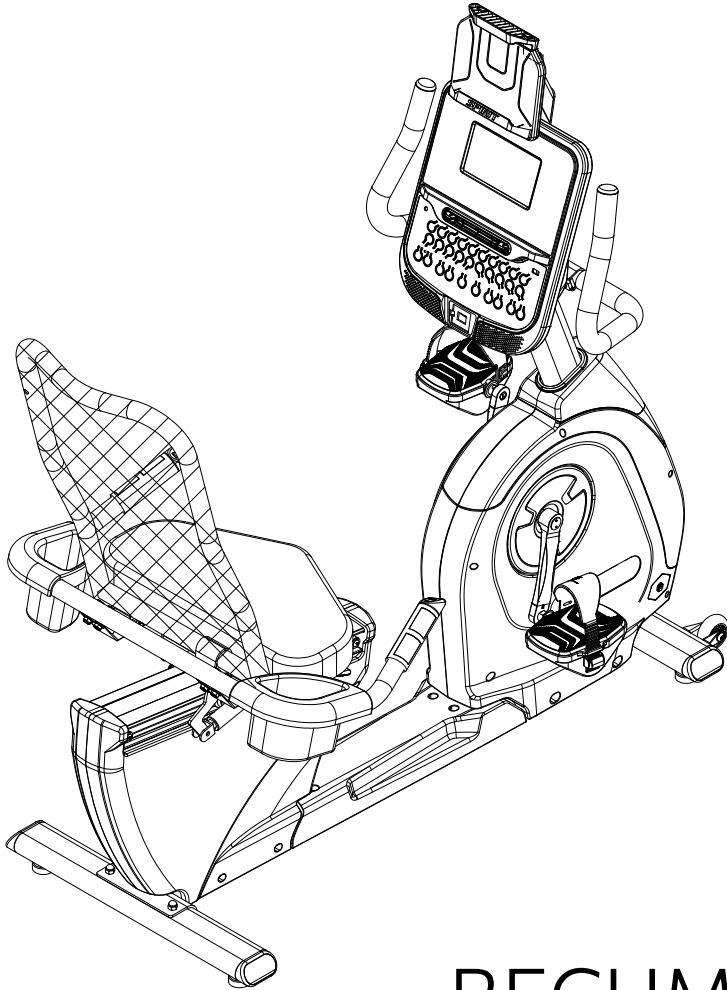

XBR95

RECUMBENT
BIKE

XBR95_951123_OM_20230725

Table of Contents

Product Registration	2	Chest Strap Warning.....	23
Warning / Safety Instructions		Heart Rate Exertion	24
Product Labels	3	Programs	
Warnings, Compliance, and Notes.....	4	Programs Intro.....	26
Safety Instructions	5	Programs - Preset	28
Parts and Assembly		Maintenance	
Parts Included	6	Maintenance & Care.....	34
Parts of Your Recumbent Bike	7	Engineering Mode.....	35
Pre-Assembly	8	Exploded View Diagram	36
Assembly.....	9	Parts List	37
Setting Up Your Unit	13	Warranty	
Quick Start	15	Warranty	41
Technology and Features			
About Your Machine	16		
Console Screen - Overview.....	17		
Console Screen - Workout Mode.....	18		
Using the Spirit+ App.....	19		
Features	20		
Heart Rate Monitoring			
Heart Rate Chest Strap	22		

PRODUCT REGISTRATION

Congratulations on your new Recumbent Bike, and welcome to the Spirit Fitness family!

Thank you for your purchase of this quality unit from Spirit Fitness. Your new unit was manufactured by one of the leading fitness manufacturers in the world and is backed by one of the most comprehensive warranties available. Through your dealer, Spirit Fitness will do all we can to make your ownership experience as pleasant as possible for many years to come.

If not purchased direct from Spirit Fitness, the local dealership where you purchased this unit is your administrator for all Spirit Fitness warranty and service needs. Their responsibility is to provide you with the technical knowledge and service personnel to make your experience more informed and any difficulties easier to remedy.

Please take a moment at this time to record the name of the dealer, their telephone number, and the date of purchase below to make any future, needed contact easy. We appreciate your support and we will always remember that you are the reason that we are in business.

Serial Number	
Date of Purchase	
Dealer / Place of Purchase	

PRODUCT LABELS

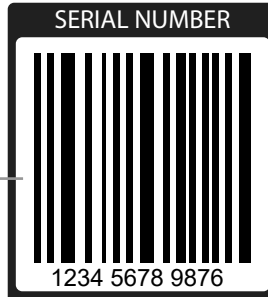

SERIAL NUMBER STICKER

This sticker will be found on the front stabilizer tube. Please record the number below the barcode for the purpose of registering your Recumbent Bike's warranty.

SAFETY WARNING STICKER

This sticker will be found on the interior side of your Recumbent Bike's upright. The same warning can be found in this manual. Please read and be aware of the precautions before operating your unit.

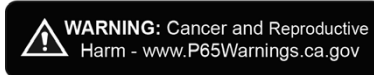

PROPOSITION 65 WARNING

This sticker will be found on the interior side of your Recumbent Bike's upright. The State of California requires us to inform you that this unit was manufactured using chemicals that could cause harm with improper use.

WARNING AVERTISSEMENT

SERIOUS INJURY COULD OCCUR IF THESE PRECAUTIONS ARE NOT OBSERVED.

- Consult your physician before use.
- Stop immediately if you become dizzy or experience chest pains and consult your physician.
- Heart Rate monitoring systems can be inaccurate; use them for reference only.
- Read all warnings on the unit and be properly instructed or read the Owner's Manual on how to use before beginning.
- Inspect this machine for damage prior to use.
- Keep body, clothing, and fitness accessories clear of moving parts.
- Risk of personal injury – Keep children under the age of 13 away from machine.

Le non respect de ces directives pourrait entraîner des blessures graves, voir mortelles:

- Consultez votre médecin avant de l'utiliser.
- Arrêtez immédiatement en cas d'étourdissements ou des douleurs à la poitrine et consultez votre médecin.
- Les lectures de fréquence cardiaque peuvent être inexactes; utiliser à titre indicatif seulement.
- Lisez tous les avertissements et les instructions sur l'appareil et dans le manuel du propriétaire avant l'utilisation.
- Inspectez cet appareil pour tout dommages avant de l'utiliser.
- Garder le corps, les vêtements et accessoires d'entraînement à l'écart des pièces mobiles.
- Risque de blessures- gardez les enfants âgés de moins de 13 ans loin de l'appareil.

WARNINGS, COMPLIANCE AND NOTICES

This product has been certified to meet the following standards:

- FCC part 15
- UL
- Bluetooth (with FTMS)

This device complies with part 15 of the FCC Rules. Operation is subject to the following two conditions: (1) this device must not cause harmful interference, and (2) this device must not accept any interference received, including interference that may cause undesired operation.

NOTE: This equipment has been tested and found to comply with the limits for a Class B digital device, pursuant to Part 15 of the FCC Rules. These limits are designed to provide reasonable protection against harmful interference in a residential installation. This equipment generates, uses and can radiate radio frequency energy and, if not installed and used in accordance with the instructions, may cause harmful interference to radio communications. However, there is no guarantee that interference will not occur in a particular installation. If this equipment does cause harmful interference to radio or television reception, which can be determined by turning the equipment off and on, the user is encouraged to try to correct the interference by one or more of the following measures:

1. Reorient or relocate the receiving antenna.
2. Increase the separation between the equipment and receiver.
3. Consult the dealer or an experienced radio/TV technician for help.

CAUTION:

- To comply with FCC RF exposure compliance requirements, a separation distance of at least 20 cm must be maintained between the antenna of this device and all persons.
- This transmitter must not be co-located or operating in conjunction with any other antenna or transmitter

SAFETY INSTRUCTIONS

To reduce risk of injury to persons:

Read all instructions before using this appliance.

 **WARNING** - To reduce the risk of burns, fire electric shock, or injury to persons:

1. This exercise equipment is not intended for use by persons with reduced physical, sensory or mental capabilities, or lack of experience and knowledge.
2. Use this appliance only for its intended use as described in this manual. Do not use attachments not recommended by the manufacturer.
3. Never operate the appliance with the air openings blocked. Keep the air openings free of lint, hair, and the like.
4. Never drop or insert any object into any opening.
5. Do not use outdoors.
6. The appliance is intended for household use.
7. Do not operate equipment on deeply padded, plush or shag carpet. Damage to both carpet and equipment may result.
8. Before beginning this or any exercise program, consult a physician. This is especially important for persons over the age of 35 or persons with pre-existing health conditions.
9. Keep hands away from all moving parts.
10. The pulse sensors are not medical devices. Various factors, including the user's movement, may affect the accuracy of heart rate readings. The pulse sensors are intended only as exercise aids in determining heart rate trends in general.
11. Do not attempt to use your equipment for any purpose other than for the purpose it is intended.
12. Wear proper shoes. High heels, dress shoes, sandals or bare feet are not suitable for use on your equipment. Quality athletic shoes are recommended to avoid leg fatigue.
13. **User Weight Limit: 350 lbs.**



Please ensure that you review and adhere to the user weight restrictions and power requirements of your new machine. Failure to do so may result in serious injury or damage to your machine.

PARTS INCLUDED

TOOLS INCLUDED:

- 12/14mm Wrench
- 13/15mm Wrench
- 13/14mm Wrench
- Phillips Head Screwdriver

PARTS INCLUDED:

- 1 Main Frame
- 1 Console Mast
- 1 Rear Stabilizer
- 1 Seat Back Frame
- 1 Front Handle Bar
- 1 Handle Bar
- 1 Seat Back Cover
- 1 Console Tablet Holder
- 1 Console
- 1 Seat Cushion
- 2 Cup Holders
- 2 Pedals
- 1 Hardware Kit

Step.1

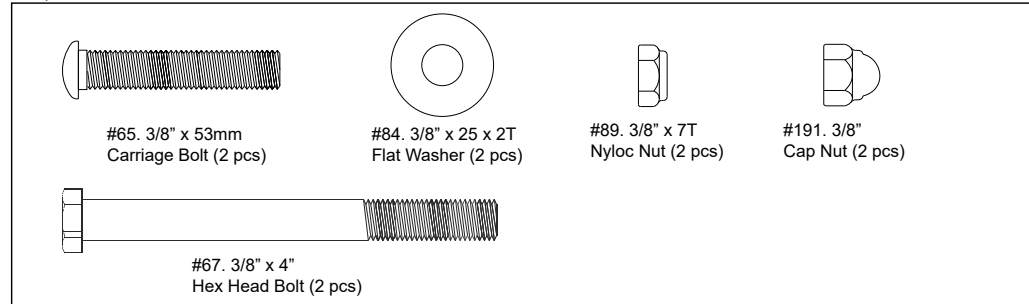

Step.2

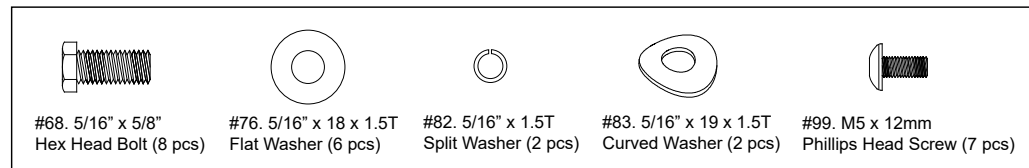

Step.3

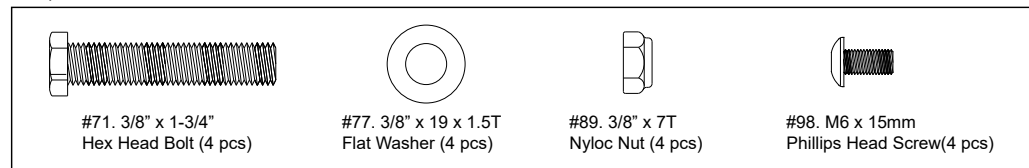

Step.4

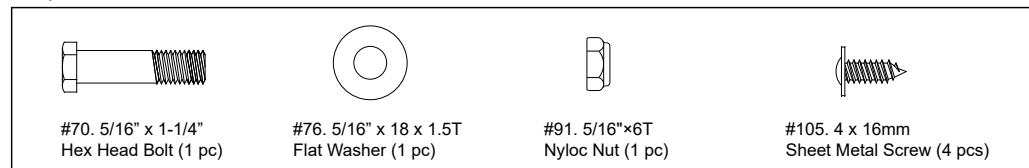

Tools

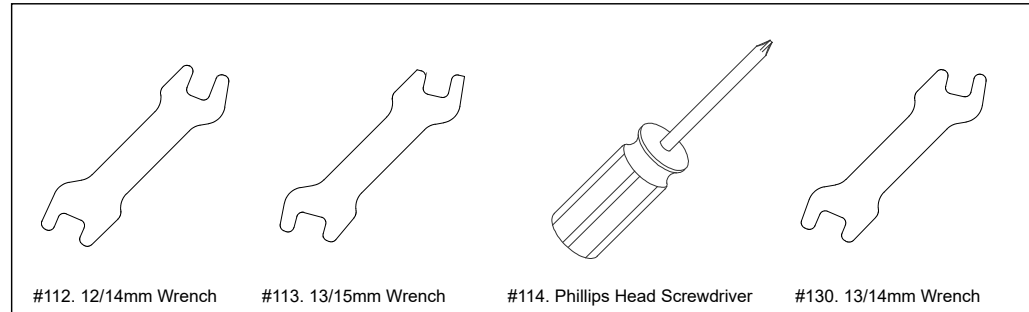

PARTS OF YOUR RECUMBENT BIKE

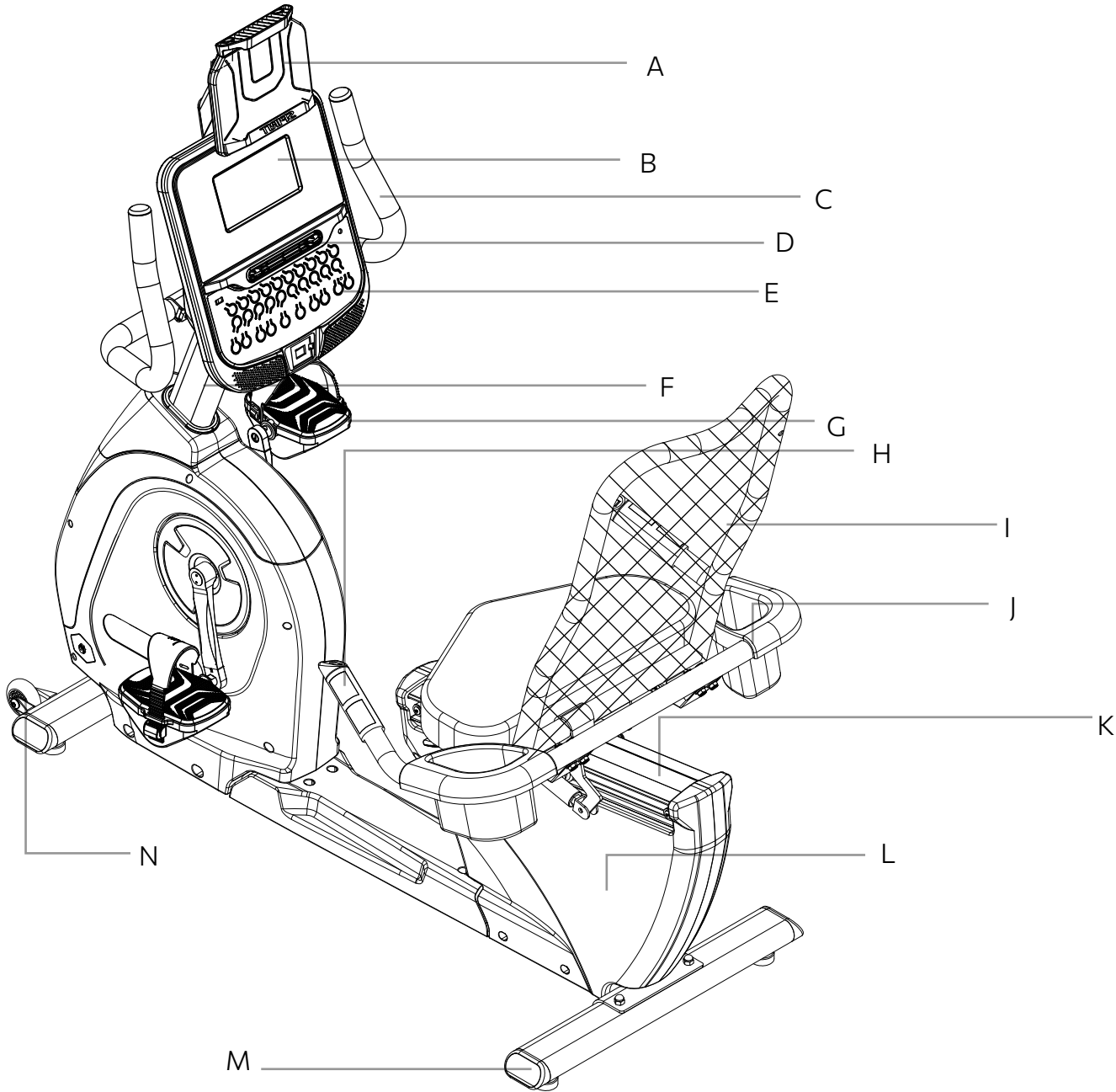

- A. Tablet Holder
- B. LCD Screen
- C. Standing Grip Handlebars
- D. Adjustable Fan
- E. Console Buttons
- F. Console Mast
- G. Adjustable Pedals
- H. Pulse Grip Handlebars
- I. Mesh Seat Back
- J. Cup Holders
- K. Seat Slide Rail
- L. Rear Frame
- M. Rear Stabilizer
- N. Transport Wheel

PRE-ASSEMBLY

1. Cut the straps, then lift the box over the unit and unpack.
2. Carefully remove all parts from the carton and inspect for any damage or missing parts. If parts are damaged or missing, contact your dealer immediately.
3. Locate the hardware package. Remove the tools first.
4. Remove the hardware for each step as needed to avoid confusion. The numbers in the instructions that are in parenthesis (#) are the item number from the assembly drawing for reference.

ASSEMBLY - STEP ONE - STABILIZER & SEAT BACK

1. Attach the **REAR STABILIZER (7)** to the **MAIN FRAME (1)** with the 2 **BOLTS (65)** and 2 **FLAT WASHERS (84)** and 2 **CAP NUTS (191)**. Tighten completely with the **WRENCH (112)**.
2. Attach the **SEAT BACK (5)** to the **SEAT CARRIAGE (4)** of the main frame. Slide 1 **BOLT (67)** through each side, then attach a **NYLON NUT (89)** to each bolt. Tighten the bolts just enough so there is no side to side play, but freedom of movement front to back. Use the **WRENCHES provided (112 & 130)**.
3. Insert an **END CAP (32)** into each opening of the **Front Stabilizer Tube**. You may need to tap them in with a rubber mallet if they are resistant to being put in.

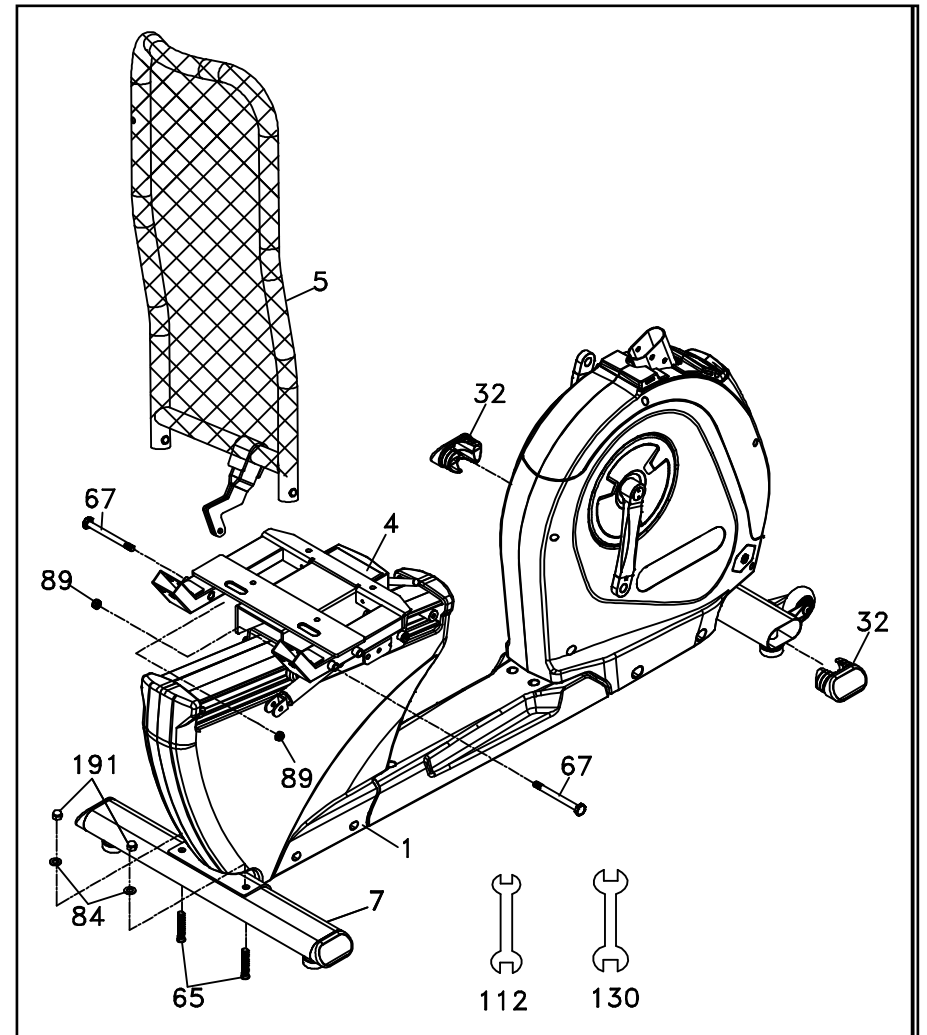

ASSEMBLY - STEP TWO - CONSOLE MAST

1. Slide the **COMPUTER CABLE (44)**, **HANDLEBAR RESISTANCE CONTROL CABLE (148)**, and **HAND PULSE CABLE (45)** through the bottom of the **CONSOLE MAST COVER (31)** and then the bottom of the **CONSOLE MAST (2)**. Make sure the Console Mast Cover is correctly oriented (see illustration).

Install the **CONSOLE MAST (2)** into the receiving tube (make sure not to pinch cables; damage to the electronics could occur) of the **MAIN FRAME (1)**. Insert 2 **BOLTS (68)** and 2 **FLAT WASHERS (76)** on each side. Insert 2 **BOLTS (68)** and 2 **CURVED WASHERS (83)** on the front. Tighten all 6 bolts firmly with the **WRENCH (112)**. Remove the white styrofoam pad (factory installed to prevent bolts from being accidentally dropped into the Console Mast Tube).

2. Insert the **COMPUTER CABLE (44)**, **HANDLEBAR RESISTANCE CONTROL CABLE (148)**, and **HAND PULSE CABLE (45)** into their respective connectors in the back of the **CONSOLE ASSEMBLY (19)**. Attach the console onto the mounting plate with 4 **PHILLIPS HEAD SCREWS (99)**. Tighten with the **PHILLIPS HEAD SCREW DRIVER (114)**.
3. Attach the **CONSOLE HOLDER (153)** to the **CONSOLE ASSEMBLY (19)** with 3 **PHILLIPS HEAD SCREWS (99)**. Tighten with the **PHILLIPS HEAD SCREW DRIVER (114)**.
4. Attach the **HANDLE BAR ASSEMBLY (3)** onto the **CONSOLE MAST (2)** bracket with 2 **BOLTS (68)**, 2 **SPLIT WASHERS (82)**, and 2 **FLAT WASHERS (76)**. Completely tighten with the **WRENCH (112)**.

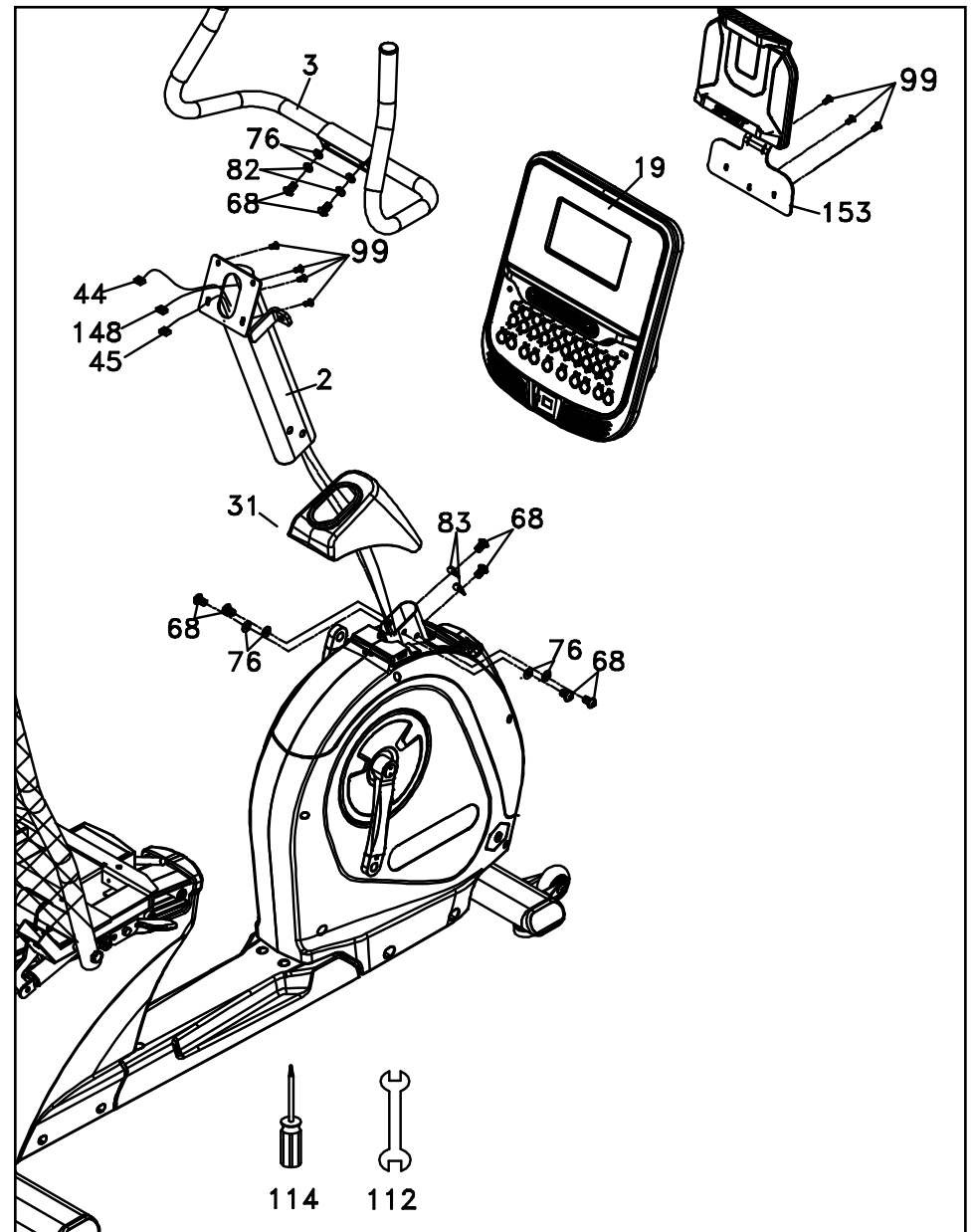

ASSEMBLY - STEP THREE - SEAT & HANDLE BAR

1. Install the **SEAT (61)** on the **SEAT CARRIAGE (4)** with 4 **PHILLIPS HEAD SCREWS (98)**. Tighten with the **PHILLIPS HEAD SCREW DRIVER (114)**.
2. Attach the **SEAT HANDLE BAR (6)** to the **SEAT CARRIAGE (4)** with the 4 **Hex Head Bolts (71)**, 4 **FLAT WASHERS (77)**, and 4 **NYLON NUTS (89)**. Tighten with the **WRENCHES** provided (112 & 130).
3. Plug the **HAND PULSE SENSOR CABLES (27)** into the rear two holes on the left side of the rear plastic cover. Plug the **HANDLEBAR RESISTANCE CABLES (150)** into the remaining front hole.

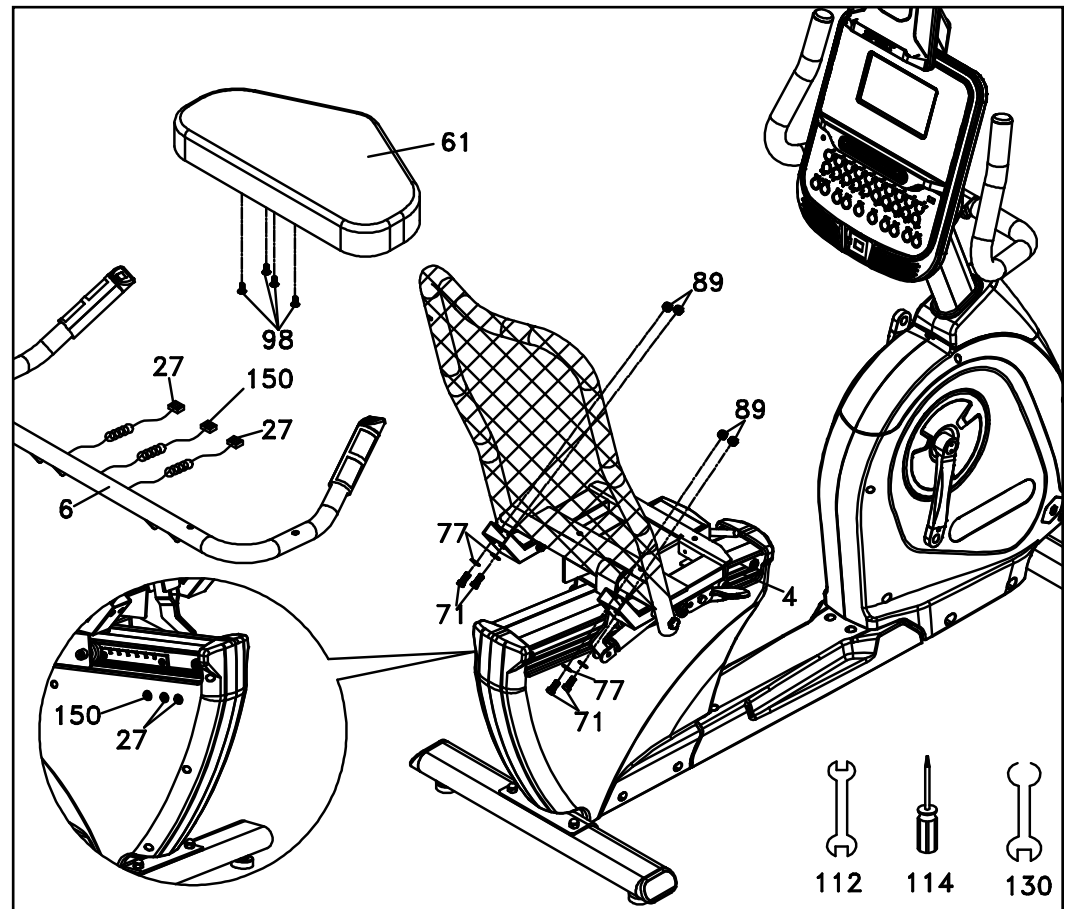

ASSEMBLY - STEP FOUR - PLASTIC PARTS

1. Install the **GAS CYLINDER (57)** on the **SEAT BACK FRAME (5)** with 1 **BOLT (70)**, 1 **FLAT WASHER (76)** and 1 **NYLON NUT (91)** by using the **WRENCHES** provided (112 & 113).
2. Attach the **PEDALS (116)** to the **CRANK ARMS (51L, 51R)**. Tighten with the **WRENCH (113)**. Remember that the **LEFT PEDAL** has a reverse thread and will be threaded onto the Crank arm in a **COUNTERCLOCKWISE** motion. There is an "L" stamped in the end of the threaded post of the left pedal and an "R" in the right. Make sure to tighten the pedals as firmly as you can. It may be necessary to re-tighten the pedals if you feel a thumping while pedaling the bike. A thumping or clicking noise is usually caused by loose pedals.
3. Attach the **DRINK BOTTLE HOLDERS (39L & 38R)** to the sides of the **SEAT HANDLE BAR (6)** with 4 **SHEET METAL SCREWS (105)**. Tighten with the **PHILLIPS HEAD SCREW DRIVER (114)**.

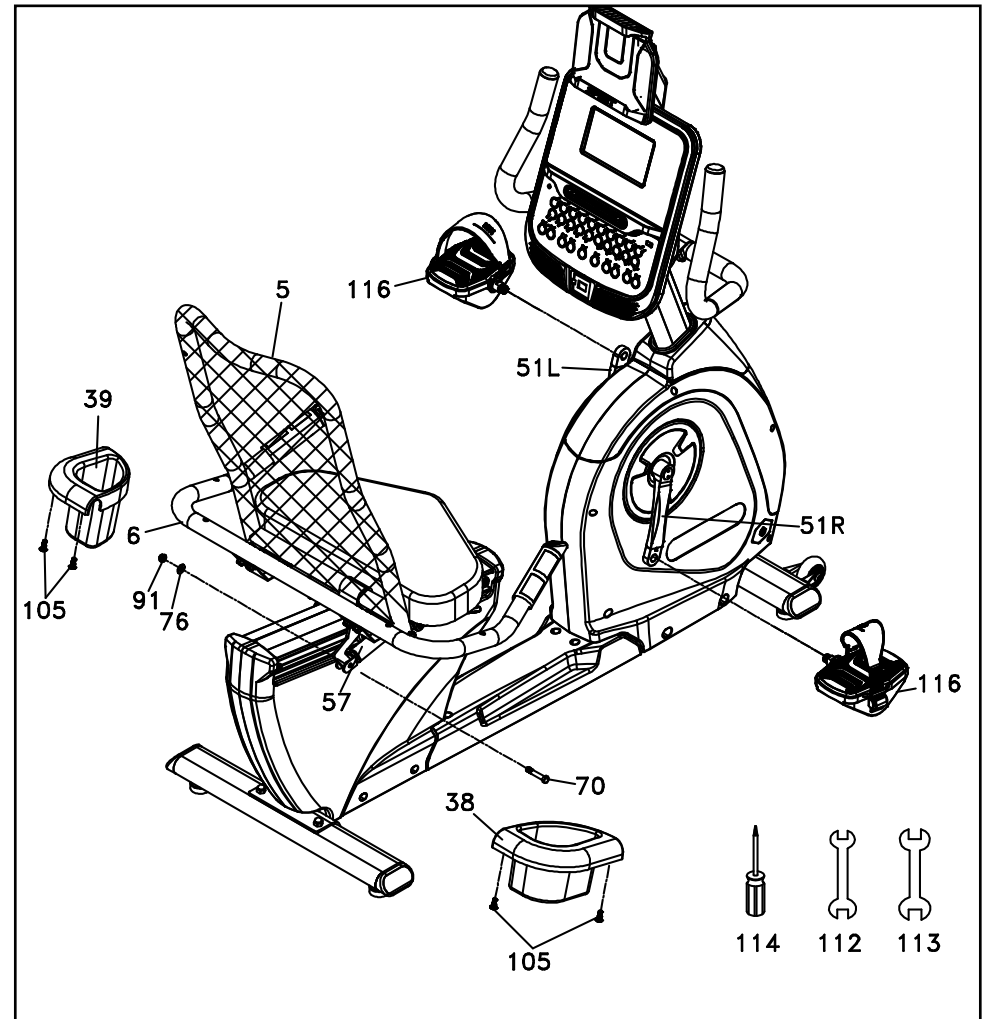

SETTING UP YOUR BIKE

Leveling

Use a M14 Wrench to adjust the height of the Leveling Feet.



Powering On

The XBR95 Recumbent Bike has a built-in generator for power and does not need to be plugged into an AC outlet. To power up the bike simply start to pedal, the console will turn on automatically.

When initially powered on the console will perform an internal self-test. During this time all the lights will turn on. When the lights go off, the Message Center will show the software version (i.e.: VER 1.0). The distance window shows the distance in miles and the time window shows the total hours of use.

The odometer will remain displayed for only a few seconds then the console will go to the start up display. The dot matrix display will be scrolling through the different profiles of the programs and the Message Center will be scrolling the start up message. You may now begin to use the console.

SETTING UP YOUR BIKE - CONTINUED

Moving The Recumbent Bike

The Recumbent Bike is equipped with 2 transport wheels on the front stabilizer. Lift the bike by the rear stabilizer and gently tilt the bike up and roll it away.



QUICK START

1. After the console powers up you just press the **Start** key to begin, this will initiate the Quick Start mode. In Quick Start the Time will count up from zero and the workload may be adjusted manually by pressing the **Level + / - buttons**. The dot matrix display will have only the bottom row lit at first. As you increase the work load more rows will light indicating a harder workout. The fitness bike will get harder to pedal as the rows increase.
2. There are 40 levels of resistance available for plenty of variety. The first 10 levels are very easy workloads and the changes between levels are set to a good progression for de-conditioned users. Levels 11-20 are more challenging, but the increases in resistance from one level to the next remain small. Levels 21-30 start getting tough as the levels jump more dramatically. Levels 31-40 are extremely hard and are good for short interval peaks and elite athletic training.

ABOUT YOUR MACHINE

 Always use care and caution when operating your machine. Follow instruction in this manual to ensure safe operation and maintenance of your Recumbent Bike

Your new Spirit Fitness Recumbent Bike has Bluetooth connectivity to give you access to the most advanced workout experiences available. Follow the instructions on page 18 and 19 to learn more about using the Bluetooth capabilities to their fullest potential.

Downloading the Spirit+ app will help unlock more features - such as tracking workouts and sharing data via Google Fit and Apple Fitness. Simply search for “Spirit+” in the app store on your smartphone or tablet, or scan the QR code on the right

Did you know that you can personalize your experience with your new Recumbent Bike? Create a profile and save custom workout programs by following the instructions on page 31.

CONSOLE SCREEN - OVERVIEW

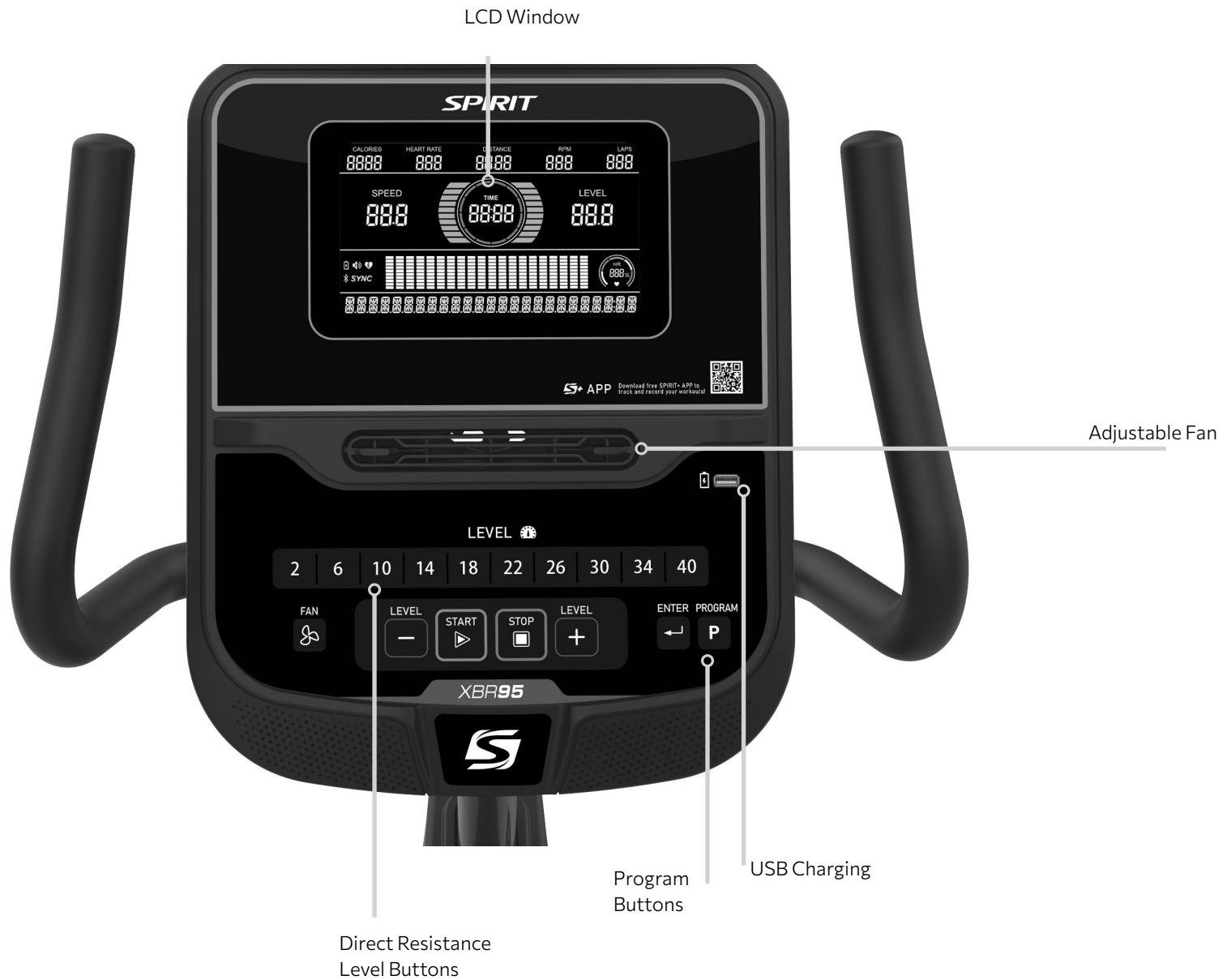

CONSOLE SCREEN - WORKOUT MODE

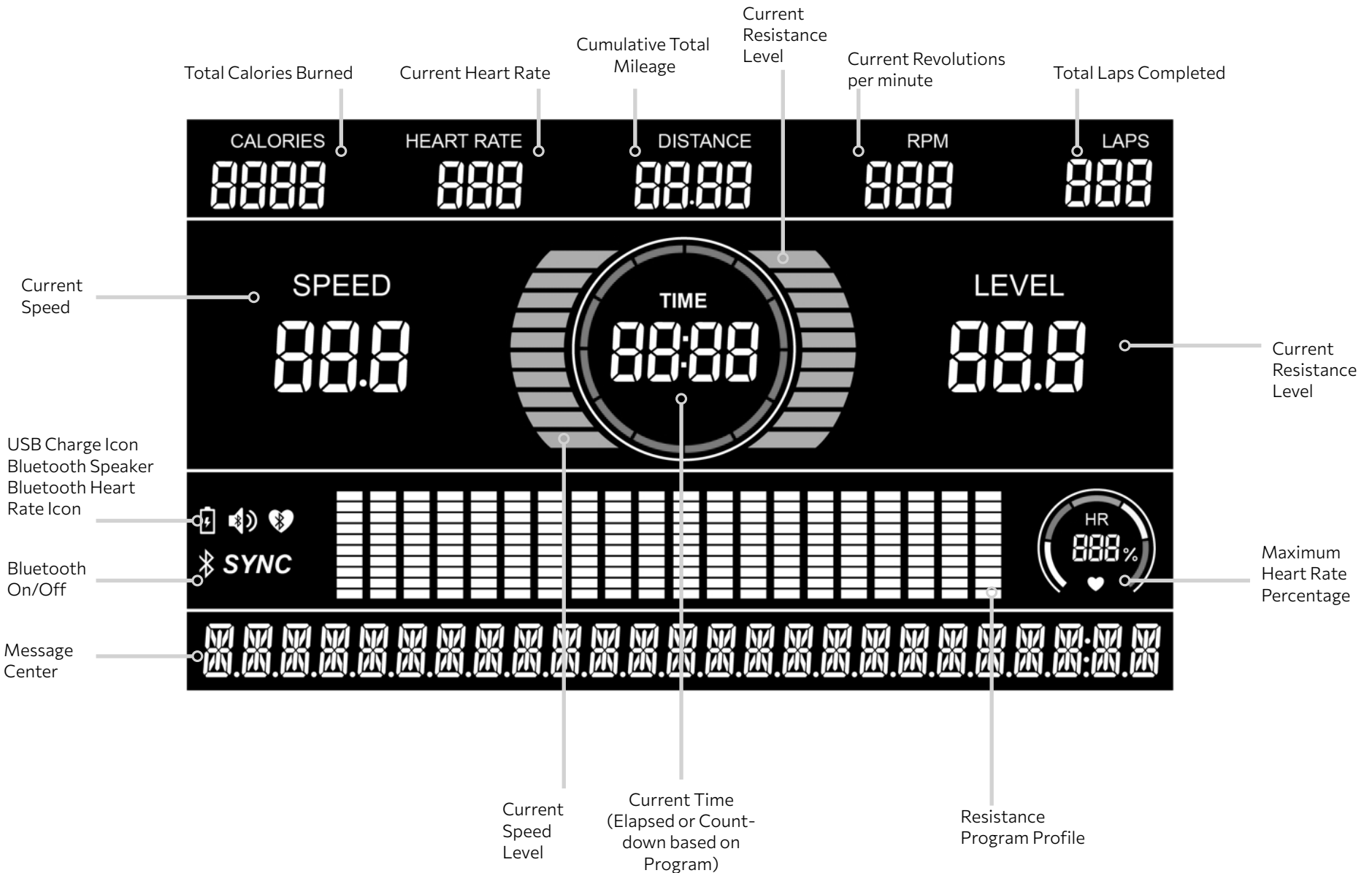

USING THE SPIRIT+ APP

In order to help you achieve your exercise goals, your new exercise machine comes equipped with a Bluetooth® transceiver that will allow it to interact with selected phones or tablet computers via the Spirit+ App. Just download the free Spirit+ App from the Apple Store or Google Play, and then follow the instructions in the App to sync with your exercise machine.

Press the “DISPLAY” button from the APP to view the display of the current workout data. When your exercise is complete, choose “END & SAVE WORKOUT” to store the workout data. The Spirit + App also allows you to sync your workout data with one of many fitness cloud sites we support: Apple Health, Google Fit, MapMyFitness or Fitbit, with more to come.

1. Download the App by scanning the QR code on the right.
2. Open the App on your device (phone or tablet) and make sure Bluetooth® is enabled on your device (phone or tablet).
3. In the App click the Bluetooth® icon to search for your Spirit + equipment.
4. Under the Bluetooth® scan result list, select the machine for connect. When the App and equipment are synced, the Bluetooth® icon on the equipment’s console display will light up. Click “DISPLAY”, you may now start using your Spirit + App.
5. When your exercise is complete, choose “END & SAVE WORKOUT” to store the workout data. You will be prompted to sync your data with each available fitness cloud site. Please note, you will have to download the applicable compatible fitness App, such as Apple Health, Google Fit, MapMyFitness, Fitbit, etc., in order for the icon to be active and available.

Note: Your device will need to be running on a minimum operating system of IOS 13.1 or Android 8.0 for the spirit + App to operate properly.

The exercise equipment can also play music wirelessly via Bluetooth®. Turn on your mobile phone or tablet’s Bluetooth® function. Search for the name “Bt-speaker” in your device’s Bluetooth® menu. Tap to connect. Now your device can transmit music to the exercise equipment.

FEATURES

Basic Information

The Stop button has several functions. Pressing the **Stop** key once during a program will pause the program for 5 minutes. If you need to get a drink, answer the phone or any of the many things that could interrupt your workout, this is a great feature.

To resume your workout during Pause, just press the **Start** key. If the Stop button is pressed twice during a workout, the program will end and the console will display your Workout Summary (Total time, Avg. Speed, Avg. Watts, Avg. HR). If the **Stop** key is held down for 3 seconds or a third time during the program, the console will perform a complete Reset. During data entry for a program the **Stop** key performs a previous screen or segment function. This allows you to go back to change programming data.

Program Keys

The Program Key is used to preview each program. When you first turn the console on you may press each program key to preview what the program profile looks like.

The fitness bike has a built in heart rate monitoring system. Simply grasping the hand pulse sensors on the stationary handle bars or wearing the heart rate transmitter (see Using Heart Rate Transmitter section) will start the Heart Icon blinking (this may take a few seconds). The Pulse Display Window will display your heart rate, or Pulse in beats per minute.

Console

The console will display RPM, Calories burned, Time (elapsed or countdown), Distance traveled, Pulse, Resistance, Program Name, number of Laps completed, and Segment Time. There is also a Resistance profile graph that lets you see how hard you have worked and how challenging the upcoming segments will be.

Dot Matrix Center Display

Twenty columns of boxes (10 high) indicate each segment of a workout. The boxes only show an approximate level (resistance) of effort. They do not necessarily indicate a specific value - only an approximate percent to compare levels of intensity. In Manual Operation the resistance dot matrix window will build a profile “picture” as values are changed during a workout.

Built-in Fan

The console includes a built-in fan to help keep you cool. To turn the fan on, press the button on the left side of the console.

FEATURES - CONTINUED

Charge Portable Devices with USB port

Charge your personal device during your workout using the fitness equipment's on-console USB port. To charge your mobile electronics make sure the fitness equipment power is on.

Step 1: Connect your USB charging cable (not included) to the USB Power Port and to your device.

Step 2: Check to make sure your device icon indicates it is charging.

NOTE:

- USB charging cable is not included, make sure compatible USB charging cable is being used.
- The USB port on the console is capable of powering USB devices. It provides up to 5Vdc/1.0 amp of power and meets USB 2.0 regulations. You will not be able to save your workout data to a USB via this port; it is used for charging purposes only.
- Minimum speed must reach to 40 RPM or above to generate enough power for USB charging.



Calorie Display

Displays the cumulative calories burned at any given time during your workout.

Note: This is only a rough guide used for comparison of different exercise sessions, and is not to be used for medical purposes.

Direct Resistance Buttons

You are able to set your resistance level setting quickly by pressing the buttons on the console. Simply choose the desired level of resistance from the console and the Recumbent Bike will automatically adjust to that level. This saves time because you don't have to press and hold or hold a button down until reaching the desired value.

Pulse Grip Feature

The Pulse (Heart Rate) console window will display your current heart rate in beats per minute during the workout. You must use both stainless steel sensors on the front cross bar or the heart rate transmitter chest strap to display your pulse. Pulse value displays anytime the upper display is receiving a Pulse signal. You may not use the Grip Pulse feature while in Heart Rate Programs.

HEART RATE CHEST STRAP* (NOT INCLUDED)

1. Attach the transmitter to the elastic strap using the interlocking key.
2. Adjust the strap as tightly as possible as long as the strap is not too tight to remain comfortable.
3. Position the transmitter with the logo centered in the middle of your torso facing away from your chest (some people must position the transmitter slightly left of center). Attach the final end of the elastic strap by inserting the round end and, using the locking parts, secure the transmitter and strap around your chest.
4. Position the transmitter directly below the pectoral muscles.
5. Sweat is the best conductor to measure very minute heart beat electrical signals. However, plain water can also be used to pre-wet the electrodes (2 ribbed oval areas on the reverse side of the belt and both sides of the transmitter). It's also recommended that you wear the transmitter strap a few minutes before your work out. Some users, because of body chemistry, have a more difficult time in achieving a strong, steady signal at the beginning. After "warming up", this problem lessens.
6. Your workout must be within range - distance between transmitter/receiver - to achieve a strong steady signal. The length of range may vary somewhat but generally stay close enough to the console to maintain good, strong, reliable readings. Wearing the transmitter directly on bare skin assures you of proper operation. If you wish, you may wear the transmitter over a shirt. To do so, wet the areas of the shirt that the electrodes will rest upon.

Note: The transmitter is automatically activated when it detects activity from the user's heart. Additionally, it automatically deactivates when it does not receive any activity. Although the transmitter is water resistant, moisture can have the effect of creating false signals, so you should take precautions to completely dry the transmitter after use to prolong battery life (estimated transmitter battery life is 2500 hours). The replacement battery is Panasonic CR2032.

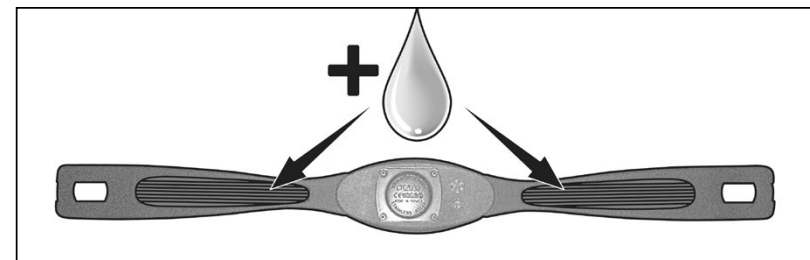
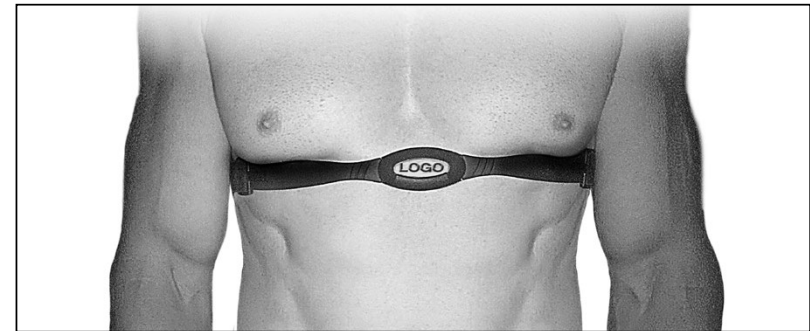

The icon  lights up and the heart rate is displayed when successfully connected to a Bluetooth® heart rate chest strap. The icon will be off when the Bluetooth® heart rate chest strap is disconnected.

CHEST STRAP WARNING* (NOT INCLUDED)

Erratic Operation

 Caution! Do not use this Recumbent Bike for Heart Rate programs unless a steady, solid Actual Heart Rate value is being displayed. High, wild, random numbers being displayed indicate a problem.

Areas to look for interference which may cause erratic heart rate:

1. Microwave ovens, TV's, small appliances, etc.
2. Fluorescent lights.
3. Some household security systems.
4. Perimeter fence for a pet.
5. Some people have problems with the transmitter picking up a signal from their skin. If you have problems try wearing the transmitter upside down. Normally the transmitter will be oriented so the Spirit Fitness logo is right side up.
6. The antenna that picks up your heart rate is very sensitive. If there is an outside noise source, turning the whole machine 90 degrees may de-tune the interference.
7. Another Individual wearing a transmitter within 3' of your machine's console.

If you continue to experience problems contact Spirit Fitness.

HEART RATE EXERTION

The old motto, “no pain, no gain”, is a myth that has been overpowered by the benefits of exercising comfortably. A great deal of this success has been promoted by the use of heart rate monitors. With the proper use of a heart rate monitor, many people find that their usual choice of exercise intensity was either too high or too low and exercise is much more enjoyable by maintaining their heart rate in the desired benefit range.

To determine the benefit range in which you wish to train, you must first determine your Maximum Heart Rate. This can be accomplished by using the following formula: 220 minus your age. This will give you the Maximum Heart Rate (MHR) for someone of your age. To determine the effective heart rate range for specific goals you simply calculate a percentage of your MHR. Your Heart rate training zone is 50% to 90% of your maximum heart rate. 60% of your MHR is the recommended for burning fat while 80% is recommended for strengthening the cardiovascular system. This 60% to 80% is the zone to stay in for maximum benefit.

For someone who is 40 years old their target heart rate zone is calculated:

$220 - 40 = 180$ (maximum heart rate)

$180 \times .6 = 108$ beats per minute (60% of maximum)

$180 \times .8 = 144$ beats per minute (80% of maximum)

So for a 40 year old the training zone would be 108 to 144 beats per minute.

If you enter your age during programming the console will perform this calculation automatically. Entering your age is used for the Heart Rate programs. After calculating your MHR you can decide upon which goal you would like to pursue.

The two most popular reasons for, or goals, of exercise are cardiovascular fitness (training for the heart and lungs) and weight control. The black columns on the chart represent the MHR for a person whose age is listed at the bottom of each column. The training heart rate, for either cardiovascular fitness or weight loss, is represented by two different lines that cut diagonally through the chart. A definition of the lines' goal is in the bottom left-hand corner of the chart. If your goal is cardiovascular fitness or if it is weight loss, it can be achieved by training at 80% or 60%, respectively, of your MHR on a schedule approved by your physician. Consult your physician before participating in any exercise program.

With all Heart Rate program you may use the heart rate monitor feature without using the Heart Rate program. This function can be used during manual mode or during any of the nine different programs.

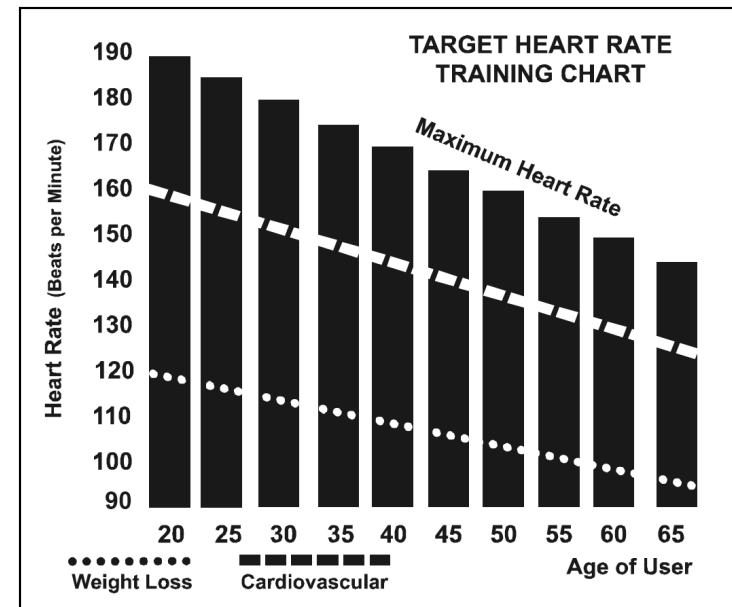

HEART RATE - PERCEIVED EXERTION

Heart rate is important but listening to your body also has a lot of advantages. There are more variables involved in how hard you should workout than just heart rate. Your stress level, physical health, emotional health, temperature, humidity, the time of day, the last time you ate and what you ate all contribute to the intensity at which you should workout. If you listen to your body it will tell you all of these things.

The rate of perceived exertion (RPE), also known as the Borg scale, was developed by Swedish physiologist G.A.V. Borg. This scale rates exercise intensity from 6 to 20 depending upon how you feel or the perception of your effort.

The scale is as follows:

You can get an approximate heart rate level for each rating by simply adding a zero to each rating. For example a rating of 12 will result in an approximate heart rate of 120 beats per minute. Your RPE will vary depending on the factors discussed earlier. If your body is strong and rested, you will feel strong and your pace will feel comfortable. When your body is in this condition, you are able to train harder and the RPE will support this. If you are feeling tired and sluggish, it is because your body needs a break. In this condition, your pace will feel difficult. Again, this will show up in your RPE and you will train at the proper level for that day.

Rating Perception of Effort

6	Minimal
7	Very, Very Light
8	Very, Very Light +
9	Very Light
10	Very Light +
11	Fairly Light
12	Comfortable
13	Somewhat Hard
14	Somewhat Hard +
15	Hard
16	Hard +
17	Very Hard
18	Very Hard +
19	Very, Very Hard
20	Maximal

PROGRAMS INTRO

Programming the Console

Each of the programs can be customized with your personal information and changed to suit your needs. Some of the information asked for is necessary to ensure the readouts are correct. You will be asked for your Age and Weight. Entering your Age is necessary during the Heart Rate programs to ensure the correct settings are in the program for your Age. Your weight is used to give a more accurate calorie count.

CALORIE NOTE: Calorie readings on every piece of exercise equipment, whether it is in a gym or at home, are not accurate and tend to vary widely. They are meant only as a guide to monitor your progress from workout to workout. The only way to measure your calorie burn accurately is in a clinical setting connected to a host of machines. This is because every person is different and burns calories at a different rate. Some good news is that you will continue to burn calories at an accelerated rate for at least an hour after you have finished exercising!

Entering a Program and Changing Settings

When you enter a program, by pressing the **Program** key, then **Enter** key, you have the option of entering your own personal settings. If you want to workout without entering new settings, then just press the **Start** key. This will bypass the programming of data and take you directly to the start of your workout. If you want to change the personal settings then just follow the instructions in the Message Center. If you start a program without changing the settings, the default or saved settings will be used.

NOTE: Age and Weight default settings will change when you enter a new number. So the last Age and Weight entered will be saved as the new default settings. If you enter your Age and Weight the first time you use the fitness bike, you will not have to enter it every time you work out unless either your Age or Weight changes or someone else enters a different Age and Weight.

PROGRAMS - TO SELECT AND START A PROGRAM

Preset

1. Press **PROGRAM** key to select the desired program button, then press the **Enter** key.
2. The Message Center will ask you to enter your Age. You may adjust the age setting, using the **+ and -** keys, then press the **Enter** key to accept the new number and proceed on to the next screen.
3. You are now asked to enter your Weight. You may adjust the weight number using the **+ and -** keys, then press **Enter** to continue.
4. Next is Time. You may adjust the Time and press **Enter** to continue.
5. Now you are asked to adjust the Max Resistance Level. This is the peak exertion level you will experience during the program (at the top of the hill). Adjust the level and then press **Enter**.
6. Now you are finished editing the settings and can begin your workout by pressing the **Start** key.
7. If you want to increase or decrease the workload at any time during the program press the **+ or -** key.
8. During the program you will be able to scroll through the data in the Message Center by pressing the **Enter** key.
9. When the program ends the Message Center will show a summary of your workout. The summary will be displayed for a short time then the console will return to the start-up display.

Manual

The Manual program works as the name implies, manually. This means that you control the workload and not the computer. To start the Manual program, follow the instructions below.

1. Press **PROGRAM** key to select Manual, then press the **Enter** key.
2. The Message Center will ask you to enter your Age. You may enter your age, using the **Level +/- keys**, then press the **Enter** key to accept the new value and proceed on to the next screen.
3. You are now asked to enter your Weight. You may adjust the Weight value using the **Level +/- keys**, then press **Enter** to continue.
4. Next is Time. You may adjust the Time and press **Enter** to continue.
5. Now you are finished editing the settings and can begin your workout by pressing the **Start** key. You can also go back and modify your settings by pressing the **Enter** key.
6. Once the program starts you will be at level one. This is the easiest level and it is a good idea to stay at level one for a while to warm up. If you want to increase the work load at any time press the **Level + key**; the **Level - key** will decrease the workload.
7. During the Manual program you will be able to scroll through the data in the Message Center by pressing the **Enter** key.
8. When the program ends you may press **Start** to begin the same program again or **Stop** to exit the program.

PROGRAMS - PRESET

The Recumbent Bike has multiple different programs that have been designed for a variety of workouts. These six programs have factory preset work level profiles for achieving different goals.

Hill

This program follows a triangle or pyramid type of gradual progression from approximately 10% of maximum effort (the level that you chose before starting this program) up to a maximum effort which lasts for 10% of the total workout time, then a gradual regression of resistance back to approximately 10% of maximum effort.

Hill

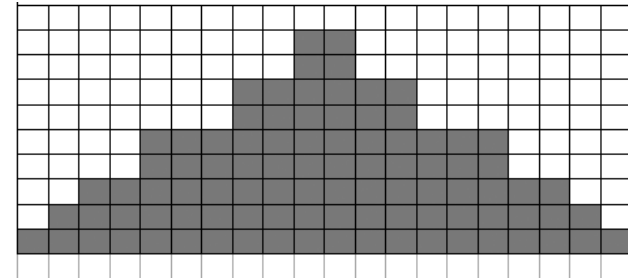

Fat Burn

This program follows a quick progression up to the maximum Resistance level (default or user input level) that is sustained for 2/3 of the workout. This program will challenge your ability to sustain your energy output for an extended period of time.

Fat Burn

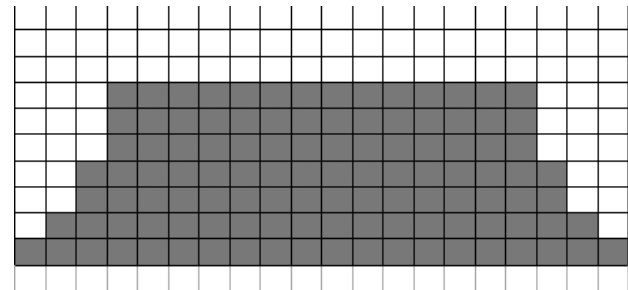

Cardio

This program presents a quick progression up to near maximum resistance level (default or user input level). It has slight fluctuations up and down to allow your heart rate to elevate, and then recover repeatedly, before beginning a quick cool down. This will build up your heart muscle and increase blood flow and lung capacity.

Cardio

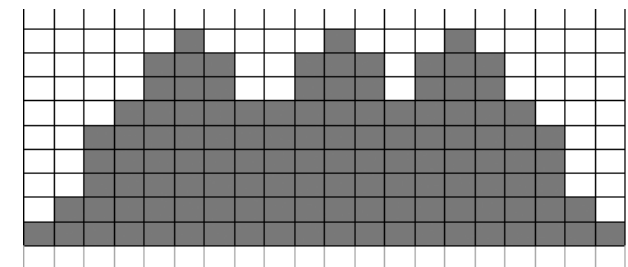

PROGRAMS

Strength

This program has a gradual progression of resistance up to 100% of maximum effort that is sustained for 25% of workout duration. This will help build strength and muscular endurance in the lower body and glutes. A brief cool down follows.

Strength

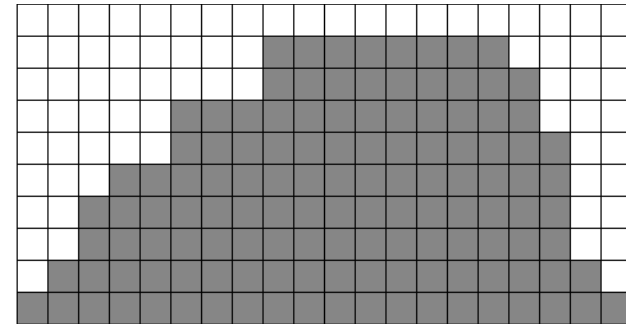

HIIT

This program takes you through high levels of intensity followed by recovery periods of low intensity. This program utilizes and develops your “Fast Twitch” muscle fibers which are used when performing tasks that are intense and short in duration. These deplete your oxygen level and spike your heart rate, followed by periods of recovery and heart rate drop to replenish oxygen. Your cardiovascular system gets programmed to use oxygen more efficiently.

HIIT

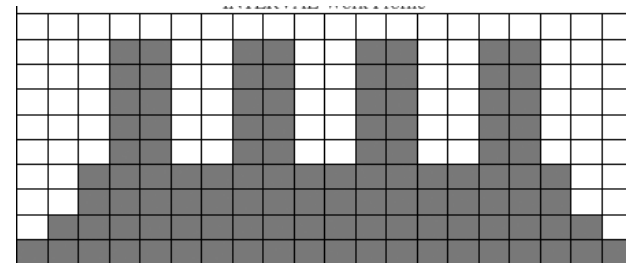

Fusion

This program takes you through high levels of cardio & strength intensity followed by recovery periods of low intensity. This program utilizes and develops your “Fast Twitch” muscle fibers which are used when performing tasks that are intense and short in duration. These deplete your oxygen level and spike your heart rate, followed by periods of recovery and heart rate drop to replenish oxygen. Your cardiovascular system gets programmed to use oxygen more efficiently.

Fusion

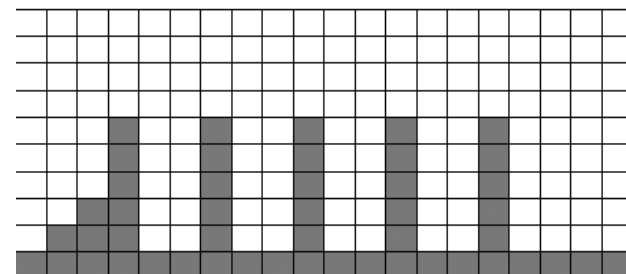

PROGRAMS

Fusion

In this interval program you will alternate between mid-high intensity cardiovascular intervals on the bike, strength exercises off of the bike, and low intensity recovery intervals on the bike. You will need a pair of objects that can be comfortably held in your hands (dumbbells, water jugs, soup cans, etc.) for 4 of the 5 strength exercises performed in this program.

1. Press **PROGRAM** key to select Fusion program button, then press the **Enter** key.
2. If **Enter** was pressed, the Message center will now be blinking a value, indicating your Age (default is 35). Use the Level +/- keys to adjust, then press Enter. Your age determines your recommended maximum heart rate. Since the Bar Graph Display and the Heart Rate features are based on a percentage of your maximum heart rate, it is important to enter the correct age for these features to work properly.
3. The Message Center will now be blinking a value, indicating your Body Weight. Entering the correct body weight will affect the calorie count. Use the **Level +/- keys** to adjust, then press **Enter**.

Note about the Calorie display: No exercise machine can give you an exact calorie count because there are too many factors which determine exact calorie burn for a particular person. Even if someone is the exact same body weight, age and height, their calorie burn may be very different than yours. The Calorie display is to be used

as a reference only to monitor improvement from workout to workout. The calorie count displayed in this program won't be accurate because the machine can't calculate calories expended while strength training.

4. The Message Center will now be blinking the preset top Resistance level of the selected program (default/minimum resistance is Level 5). Use the **Level +/- keys** to adjust, then press Enter. This value will be the Level for all cardio intervals. The resistance level can be adjusted at any time during the program.
5. The Message Center will be blinking the number of intervals desired (default is 10); you may select 10 (5 cardio & 5 strength), 20 (10 cardio & 10 strength), or 30 (15 cardio & 15 strength). Use the Level +/- keys to adjust, then press **Enter**.
6. The Message Center will be blinking the desired Interval time (default is 2:00). The time you select will be the duration of each cardio interval. Note: As a general rule, the longer the interval, the less resistance (fitness bike) is required and the more repetitions you perform, the less weight (dumbbells) you need to use; use the Level +/- keys to adjust, then press **Enter**.
7. The Message Center will be blinking the recovery time you desire (default is 0:30) after completing both the cardio & strength intervals. Use the **Level +/- keys** to adjust, then press Enter.

CAUTION: The shorter the recovery time, the longer your heart rate will stay elevated; if you are new to exercise or have recently resumed an exercise program after a considerable amount of time off, it is recommended that your recovery interval length either matches or exceeds the length of the cardio interval.

PROGRAMS

Countdown Mode

Target programs can be set a Target Time, Target Distance or Target Calories for your workout. When the program begins the target item will count down; once it reaches zero the program ends.

1. Press **PROGRAM** key to select **TARGET PROGRAM**, then press **Enter**.
2. Press **PROGRAM** key to select the Target Time program, Target Distance program or Target Calories program. Press **Enter** to set the program. The display will prompt you through the programming or you can just press **Start** to begin the program with default values.
3. If **Enter** was pressed, the Message center will now be blinking a value, indicating your **Age** (default is 35). Use the + or – keys to adjust, then press **Enter**.
4. The Message center will now be blinking a value, indicating your **Body Weight** (default is 155 lbs/ 70kgs.). Entering the correct body weight will affect the calorie count. Use the + or – **keys** to adjust, then press **Enter**.
5. In Target Time program, the Message Center will be blinking a value, indicating **Time** (the default value is 5 minutes) In Target Distance program, the Message Center will be blinking a value, indicating **Distance** (the default value is 3.00 mile) In Target Calories program, the Message Center will be blinking a value, indicating **Calories** (the default value is 300). You may use any of the + or - **keys** to adjust the target item. After adjusting, or to accept the default, press **Enter**.
6. You are now done programming data and may press **Start** to begin your workout.

A note about the Calorie display: No exercise machine can give you an exact calorie count because there are too many factors which determine exact calorie burn for a particular person. Even if someone is the exact same body weight, age and height, their calorie burn may be very different than yours. The Calorie display is to be used as a reference only to monitor improvement from workout to workout.

PROGRAMS

Custom Workout Program

There are two customizable User programs that allow you to build and save your own workout. The two programs, Custom 1 and Custom 2, operate exactly the same way so there is no reason to describe them separately. You can build your own custom program by following the instructions below or you can save any other preset program you complete as a custom program. Both programs allow you to further personalize it by adding your name.

1. Press **PROGRAM** key to select Custom program button (Custom 1 or Custom 2), then press the **Enter** key. If you have already saved a program to either Custom 1 or Custom 2, it will be displayed and you are ready to begin. If not, you will have the option of inputting a username. In the Message Window, the letter "A" will be blinking. Use the **Level +/- buttons** to select the appropriate first letter of your name (pressing the **LEVEL +/- button** will switch to the letter "B"; pressing the Down button will switch to letter "Z"). Press **Enter** when the desired letter is displayed. Repeat this process until all of the characters of your name have been programmed (maximum 7 characters). When finished press **Stop**.
2. If there is a program already stored in Custom when you press the key, you will have an option to run the program as it is or delete the program and build a new one. At the welcome message screen, when pressing **Start** or **Enter** you will be prompted: Run Program? Use the **Level +/-** to select Yes or No. If you select No, you will then be asked if

you want to delete the currently saved program. It is necessary to delete the current program if you want to build a new one. The Message Center will ask you to enter your Age. You may enter your age, using the **Level +/- keys**, then press the **Enter** key to accept the new value and proceed on to the next screen.

3. The Message Center will ask you to enter your Age. You may enter your age, using the **Level +/- keys**, then press the **Enter** key to accept the new value and proceed on to the next screen.
4. You are now asked to enter your Weight. You may adjust the weight value using the **Level +/- keys**, then press **Enter** to continue.
5. Next is Time. You may adjust the time and press **Enter** to continue.
6. Now the first column will be blinking and you are asked to adjust the resistance level for the first segment (SEGMENT> 1) of the workout by using the **Level +/- key**. When you finish adjusting the first segment, or if you don't want to change, then press **Enter** to continue to the next segment.
7. The next segment will show the same workload resistance level as the previously adjusted segment. Repeat the same process as the last segment then press **Enter**. Continue this process until all twenty segments have been set.
8. Now you are finished editing the settings and can begin your workout by pressing the **Start** key. You can also go back and modify your settings by pressing the **Enter** key.

PROGRAMS

Heart Rate Program Operation

Note: You must wear the heart rate transmitter strap for these programs. Both programs operate the same.

Heart Rate programs operate the same, the only difference is that **HR1** is set to 55%, **HR2** is set to 65%, **HR3** is set to 75% and **HR4** is set to 85% of the maximum heart rate. They are programmed the same way. To start an HR program follow the instructions below or just select the **HR 55%, HR 65%, HR 75% or HR 85%** program, then the Enter button and follow the directions in the **Message Center**.

After selecting your heart rate target, the program will attempt to keep you at or within 3 - 5 heart beats per minute of this value. Follow the prompts in the **Message Center** to maintain your selected heart rate value.

1. Press the **PROGRAM KEY** to select **HR PROGRAM** then press **ENTER**.
2. Press the **PROGRAM key** to select target HR 55%, target HR 65%, target HR 75% or target 85%, then press the **Enter** key.
3. The Message Center will ask you to enter your **Age**. You may enter your age, using the **Level + or - keys**, then press the **Enter** key to accept the new value and proceed on to the next screen.
4. You are now asked to enter your **Weight**. You may adjust

the weight value using the **Level + or - keys**, then press **Enter** to continue.

5. Next is **Time**. You may adjust the time using the **Level + or - keys** and press Enter to continue.
6. Now you are asked to adjust the Heart Rate Target. This is the heart rate level you will strive to maintain during the program. Adjust the level using the **Level + or - keys**, then press **Enter**.

Note: The heart rate that appears is based on the % you accepted in Step 2. If you change this number it will either increase or decrease the % from Step 2.

7. Now you are finished editing the settings and can begin your workout by pressing the **Start** key. You can also go back and modify your settings by pressing the **Enter** key.

Note: At any time during the editing of Data you can press the **Stop** key to go back one screen.

8. If you want to increase or decrease the workload at any time during the program press the **Level + or - key** on the console. This will allow you to change your target heart rate at any time during the program.

MAINTENANCE & CARE

Post-Workout Machine Care

1. Store your machine according to the instructions when not in use.
2. Use a slightly damp cloth to clean areas where sweat or oil made contact with the machine.
3. Use a microfiber cloth to clean the screen and remove unwanted oils and other things that may damage the screen.
4. Avoid leaving paper or other small debris in the cupholders.

Sanitizing Your Spirit Fitness Equipment

- Unupholstered high-contact surfaces (hard plastics) can be sanitized using a 75% isopropyl alcohol solution and a clean, dry cloth. Spray surfaces to be sanitized, and use the dry cloth to wipe clean. Allow surfaces to dry before using.
- For upholstered or soft-plastic surfaces, use a conditioner after sanitizing. Be sure to follow the instructions provided by the conditioner manufacturer to ensure proper use of the conditioner.
- Alternatively, you can make your own spray by mixing the proper ratio of isopropyl alcohol and distilled water to reach a 75% solution.

ENGINEERING MODE MENU

The console has built in maintenance/diagnostic software. The software will allow you to change the console settings from English to Metric and turn off the beeping of the speaker when a key is pressed for example. To enter the Engineering Mode Menu, press and hold down the **Start, Stop** and **Enter** keys. Keep holding the keys down for about 5 seconds and the Message Center will display Engineering Mode Menu. Press the **Enter** key to access the menu below:

1. Key Test (Will allow you to test all the keys to make sure they are functioning)
2. Display Test (Tests all the display functions)
3. Functions (Press Enter to access settings and + or- arrow to scroll)
 - ODO Reset (Resets the odometer)
 - Units (Sets the display to readout in English or Metric display measurements)
 - Pause Mode (Turn on allow 5 minutes of pause, turn off to have the console pause indefinitely)
 - Beep (Turns off the speaker so no beeping sound is heard)
 - PWM test (Test the Brake resistance)
4. Exit

EXPLODED VIEW DIAGRAM

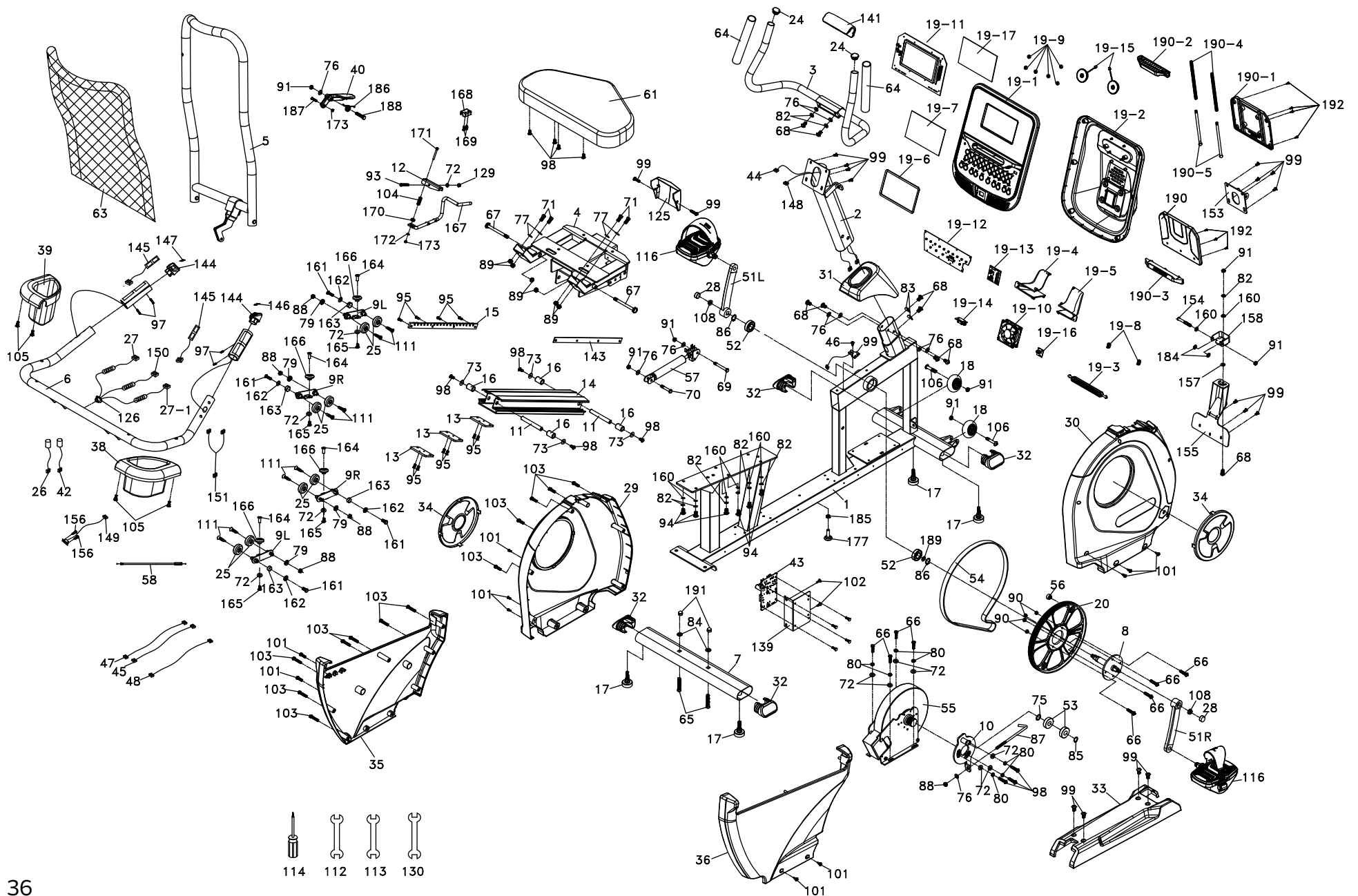

PARTS LIST

1	Main Frame	1
2	Console Mast	1
3	Mast Handle bar Assembly	1
4	Seat Carriage	1
5	Seat Back Frame	1
6	Seat Handle Bar	1
7	Rear Stabilizer	1
8	Crank Axle	1
9L	Seat Wheel Adjustment Plate (L)	2
9R	Seat Wheel Adjustment Plate (R)	2
10	Idler Wheel Assembly	1
11	Seat Stop Axle	2
12	Seat Position Latch	1
13	Backing Plate	3
14	Aluminum Track	1
15	Rack	1
16	Spacer for Stopper Axle	4
17	Rubber Foot	4
18	Transportation Wheel	2
19	Console Assembly	1
19-1	Console Top Cover	1
19-2	Console Bottom Cover	1
19-3	Deflector Fan Grill	1
19-4	Wind Duct (L)	1
19-5	Wind Duct (R)	1
19-6	Water-resist Rubber	1
19-7	LCD Transparent Piece	1

19-8	Fan Grill Anchor	2
19-9	Speaker Grill Anchor	6
19-10	Fan Assembly	1
19-11	Console Display Board	1
19-12	Main Key Board	1
19-13	Interface Board	1
19-14	W/Receiver, HR	1
19-15	Speaker W/Cable	2
19-16	USB Board	1
19-17	Backlit Board	1
20	Drive Pulley	1
24	Button Head Plug	2
25	Seat Track Wheel	8
26	300mm_Hand Pulse Sensor Assembly W/ Cable	1
27	750mm_Handpulse W/Cable Assembly(L)	1
27-1	950mm_Handpulse W/Cable Assembly(R)	1
28	Crank Arm End Cap	2
29	Front Shroud (L)	1
30	Front Shroud (R)	1
31	Console Mast Cover	1
32	Handgrip End Cap	4
33	Bottom Cover	1
34	Round Disk Cover	2
35	Rear Shroud (L)	1
36	Rear Shroud (R)	1
38	Drink Bottle Holder (R)	1

PARTS LIST

39	Drink Bottle Holder (L)	1
40	Release Lever	1
42	300mm_Hand Pulse Sensor Assembly W/ Cable	1
43	Generator/Brake Controller	1
44	Computer Cable	1
45	2300mm_Hand Pulse Sensor Assembly W/ Cable	1
46	1300mm_Sensor W/Cable	1
47	800mm_Wire Brake Coil Harness	1
48	Generator Wire Harness	1
51L	Crank Arm(L)	1
51R	Crank Arm(R)	1
52	6004_Bearing	2
53	6203_Bearing	2
54	Drive Belt	1
55	Flywheel	1
56	Magnet	1
57	Gas Cylinder	1
58	Steel Cable	1
61	Seat	1
63	Mesh Seat Back	1
64	Handgrip Foam	2
65	3/8" × 53mm_Carriage Bolt	2
66	1/4" × 3/4" _Hex Head Bolt	8
67	3/8" × UNC16 × 4" _Hex Head Bolt	2
68	5/16" × UNC18 × 5/8" _Hex Head Bolt	9

69	5/16" × 2-1/2" _Hex Head Bolt	1
70	5/16" × UNC18 × 1-1/4" _Hex Head Bolt	1
71	3/8" × 1-3/4" _Hex Head Bolt	4
72	Ø1/4" × 13 × 1T _Flat Washer	12
73	Ø1/4" × 19 × 1.5T _Flat Washer	4
75	Ø17 × Ø23.5 × 1T _Flat Washer	1
76	Ø5/16" × Ø18 × 1.5T _Flat Washer	10
77	Ø3/8" × Ø19 × 1.5T _Flat Washer	4
79	Ø8 × Ø18 × 3T _Knurled Lock Washer	4
80	Ø1/4" _Split Washer	7
82	5/16" × 1.5T _Split Washer	9
83	Ø5/16" × 19 × 1.5T _Curved Washer	2
84	Ø3/8" × Ø25 × 2T _Flat Washer	2
85	Ø17 _C Ring	1
86	Ø20 _C Ring	2
87	M8 × 170mm _J Bolt	1
88	M8 × 7T _Nylon Nut	5
89	3/8" × 7T _Nylon Nut	6
90	1/4" × 8T _Nylon Nut	4
91	5/16" × 6T _Nylon Nut	7
93	M6 × 38mm _Socket Head Cap Bolt	1
94	5/16" × UNC18 × 3/4" _Hex Head Bolt	6
95	M5 × 12mm _Flat Head Socket Screw	10
97	3 × 20mm _Tapping Screw	4
98	M6 × 15mm _Phillips Head Screw	11
99	M5 × 12mm _Phillips Head Screw	18
101	Ø5 × 16mm _Tapping Screw	10

PARTS LIST

102	5 × 19mm_Tapping Screw	2
103	Ø3.5 × 16mm_Sheet Metal Screw	12
104	Spring	1
105	4 × 16mm_Sheet Metal Screw	4
106	5/16" × UNC18 × 1- 3/4" _Button Head Socket Bolt	2
108	M10 × P1.25 × 10T_Nut	2
111	M5 × P0.8 × 10L_Flat Phillips Head Screw	8
112	12/14mm_Wrench	1
113	13/15mm_Wrench	1
114	Phillips Head Screw Driver	1
116	Pedal (L.R)	1
125	Seat Carriage Cover	1
126	HGP Wire Grommet	1
129	M6 × 6T_Nylon Nut	1
130	13/14mm_Wrench	1
139	Fixing Plate	1
141	Handle Bar Cover	1
143	Seat Track Fixing Plate	1
144	Handgrip End Cap	2
145	Resistance Button W/Cable	2
146	Handgrip Resistance Label (UP)	1
147	Handgrip Resistance Label (DOWN)	1
148	2300mm_Switch Cable (Upper)	1
149	300mm_Handle Switch Bracket	1
150	180mm_Resistance Connecting Cable	1
151	Switch Cable (Lower)	1

153	Console Holder Assembly	1
154	5/16" × 2-1/2" _Hex Head Bolt	1
155	Tablet Holder Assembly	1
156	2.3 × 6mm_Sheet Metal Screw	2
157	Pad	1
158	Rotate Axle Bracket	1
160	Ø5/16" × 16 × 1.5T_Flat Washer	8
161	M6 × 10L_Flat Phillips Head Screw	4
162	Ø1/4" × Ø16 × 1.0T_Flat Washer	4
163	Sleeve	4
164	M6 × 19L_Nut	4
165	M6 × 10L_Button Head Socket Bolt	4
166	PU Wheel	4
167	Seat Front/Aft Adjustment Lever	1
168	Lever Anchor	1
169	M5 × 25mm_Flat Head Socket Screw	2
170	Ø15 × Ø6 × 4T_Nylon Washer	1
171	M5 × 45mm_Socket Head Cap Bolt	1
172	Ø5 × Ø10 × 1.0T_Flat Washer	1
173	M5 × 5T_Nylon Nut	2
177	Rubber Foot Pad	1
184	Flat Washer	2
185	3/8" × 4T_Nut	1
186	ChenChin Torsion-Spring	1
187	M5 × 20L_Phillips Head Screw	1
188	5/16" × UNC18 × 1-1/2" _Hex Head Bolt	1
189	Rubber Pad	2

PARTS LIST

190	Tablet Holder Front Cover	1
190-1	Tablet Holder Rear Cover	1
190-2	Tablet Holder Top clip	1
190-3	Tablet Holder Bottom clip	1
190-4	Spring	2
190-5	Spring column	2
191	3/8" × UNC16 × 12.5T_Cap Nut	2
192	3.5 × 12mm_Sheet Metal Screw	7

WARRANTY - RESIDENTIAL

Effective July 25, 2023- XBR95 Recumbent Bike LIMITED WARRANTY

Spirit Fitness Inc. warrants all its home use Recumbent Bike parts for a period of time listed below, from the date of retail sale, as determined by a sales receipt or in the absence of a sales receipt, eighteen (18) months from the original factory shipping date. Spirit Fitness's responsibilities include providing new or remanufactured parts, at Spirit Fitness's option, and technical support to our independent dealers and servicing organizations. In the absence of a dealer or service organization, these warranties will be administered by Spirit Fitness directly to a consumer. The warranty period applies to the following components:

Home Use Limited Warranty

Warranty	Frame	Brake	Parts	Labor
Residential	Lifetime	Lifetime	10 Years	1 Year

Light Commercial Warranty*

*Prisons and correctional facilities are excluded from warranty coverage

Warranty	Frame	Brake	Parts	Labor
Light Commercial	Lifetime	5 Years	3 Years	1 Year

RESPONSIBILITIES OF THE CONSUMER

This warranty applies only to products in ordinary household or light commercial use, and the consumer/facility is responsible for the items listed below:

1. Proper use of the Recumbent Bike in accordance with the instructions provided in this manual
2. Proper installation in accordance with instructions provided with the Recumbent Bike and with all local electric codes.
3. Expenses for making the Recumbent Bike accessible for servicing, including any item that was not part of the Recumbent Bike at the time it was shipped from the factory.
4. Damages to the Recumbent Bike finish during shipping, installation or following installation.
5. Routine maintenance of this unit as specified in this manual.

WARRANTY - CONTINUED

What is not covered?

EXCLUSIONS

This warranty does not cover the following:

1. CONSEQUENTIAL, COLLATERAL, OR INCIDENTAL DAMAGES SUCH AS PROPERTY DAMAGE AND INCIDENTAL EXPENSES RESULTING FROM ANY BREACH OF THIS WRITTEN OR ANY IMPLIED WARRANTY.
Note: Some states do not allow the exclusion or limitation of incidental or consequential damages, so this limitation or exclusion may not apply to you.
2. Service call reimbursement to the consumer. Service call reimbursement to the dealer that does not involve malfunction or defects in workmanship or material, for units that are beyond the warranty period, for units that are beyond the service call reimbursement period, for Recumbent Bike not requiring component replacement, or Recumbent Bike not in ordinary household or light commercial use.
3. Damages caused by services performed by persons other than authorized Spirit Fitness service companies; use of parts other than original Spirit Fitness parts; or external causes such as corrosion, discoloration of paint or plastic, alterations, modifications, abuse, misuse, accident, improper maintenance, inadequate power supply, or acts of God.
4. Products with original serial numbers that have been removed or altered.
5. Products that have been: sold, transferred, bartered, or given to a third party.
6. Spirit Fitness reserves the right to request proof of purchase if no warranty record exists for the product.
7. THIS WARRANTY IS EXPRESSLY IN LIEU OF ALL OTHER WARRANTIES EXPRESSED OR IMPLIED, INCLUDING THE WARRANTIES OF MERCHANTABILITY AND/OR FITNESS FOR A PARTICULAR PURPOSE.
8. Product use in any environment other than a residential setting or non-dues paying facility with 5 hours use or less per day.
9. Warranties outside of the United States may vary. Please contact your local dealer for details.

Product features or specifications as described or illustrated are subject to change without notice. All warranties are made by Spirit Fitness, Inc. This warranty applies only in the 48 contiguous United States. NOTE: This does not include Alaska or Hawaii.

WARRANTY - CONTINUED

Responsibilities of the Owner

SERVICE

Keep your bill of sale. Twelve (12) months from the date on the bill of sale or eighteen (18) months from the date of factory shipping as determined by the serial number establishes the labor warranty period should service be required. If service is performed, it is in your best interest to obtain and keep all receipts. This written warranty gives you specific legal rights. You may also have other rights that vary from state to state. Service under this warranty must be obtained by following these steps, in order:

1. Contact your selling authorized Spirit Fitness dealer. OR
2. Contact your local authorized Spirit Fitness service organization.

4. Spirit Fitness' obligation under this warranty is limited to repairing or replacing, at Spirit Fitness' option, the product through one of our authorized service centers. All repairs must be preauthorized by Spirit Fitness. If the product is shipped to a service center freight charges to and from the service center will be the customer's responsibility. For replacement parts shipped while the product is under warranty, the customer will be responsible for shipping and handling charges. For in-home service, the customer will be responsible for a trip charge. There will be an additional trip charge if the customer is located over 100 miles from the nearest service center.
5. The owner is responsible for adequate packaging upon return to Spirit Fitness. Spirit Fitness is not responsible for damages in shipping. Make all freight damage claims with the appropriate freight carrier. **DO NOT SHIP ANY UNIT TO OUR FACTORY WITHOUT A RETURN AUTHORIZATION NUMBER.** All units arriving without a return authorization number will be refused.

Product features or specifications as described or illustrated are subject to change without notice. All warranties are made by Spirit Fitness, Inc. This warranty applies only in the 48 contiguous United States. NOTE: This does not apply to Alaska or Hawaii.